

SUPERO[®]

A+ SERVER 2022TG-HTRF
A+ SERVER 2022TG-HIBQRF

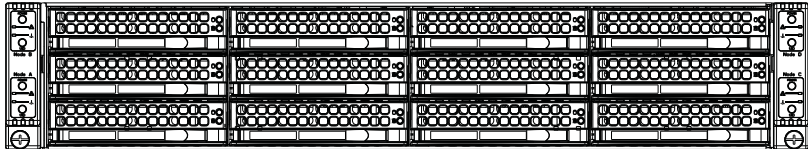

USER'S MANUAL

Revision 1.0

The information in this User's Manual has been carefully reviewed and is believed to be accurate. The vendor assumes no responsibility for any inaccuracies that may be contained in this document, makes no commitment to update or to keep current the information in this manual, or to notify any person or organization of the updates. **Please Note: For the most up-to-date version of this manual, please see our web site at www.supermicro.com.**

Super Micro Computer, Inc. ("Supermicro") reserves the right to make changes to the product described in this manual at any time and without notice. This product, including software and documentation, is the property of Supermicro and/or its licensors, and is supplied only under a license. Any use or reproduction of this product is not allowed, except as expressly permitted by the terms of said license.

IN NO EVENT WILL SUPERMICRO BE LIABLE FOR DIRECT, INDIRECT, SPECIAL, INCIDENTAL, SPECULATIVE OR CONSEQUENTIAL DAMAGES ARISING FROM THE USE OR INABILITY TO USE THIS PRODUCT OR DOCUMENTATION, EVEN IF ADVISED OF THE POSSIBILITY OF SUCH DAMAGES. IN PARTICULAR, SUPERMICRO SHALL NOT HAVE LIABILITY FOR ANY HARDWARE, SOFTWARE, OR DATA STORED OR USED WITH THE PRODUCT, INCLUDING THE COSTS OF REPAIRING, REPLACING, INTEGRATING, INSTALLING OR RECOVERING SUCH HARDWARE, SOFTWARE, OR DATA.

Any disputes arising between manufacturer and customer shall be governed by the laws of Santa Clara County in the State of California, USA. The State of California, County of Santa Clara shall be the exclusive venue for the resolution of any such disputes. Super Micro's total liability for all claims will not exceed the price paid for the hardware product.

FCC Statement: This equipment has been tested and found to comply with the limits for a Class A digital device pursuant to Part 15 of the FCC Rules. These limits are designed to provide reasonable protection against harmful interference when the equipment is operated in a commercial environment. This equipment generates, uses, and can radiate radio frequency energy and, if not installed and used in accordance with the manufacturer's instruction manual, may cause harmful interference with radio communications. Operation of this equipment in a residential area is likely to cause harmful interference, in which case you will be required to correct the interference at your own expense.

California Best Management Practices Regulations for Perchlorate Materials: This Perchlorate warning applies only to products containing CR (Manganese Dioxide) Lithium coin cells. "Perchlorate Material-special handling may apply. See www.dtsc.ca.gov/hazardouswaste/perchlorate"

WARNING: Handling of lead solder materials used in this product may expose you to lead, a chemical known to the State of California to cause birth defects and other reproductive harm.

Manual Revision 1.0

Release Date: December 30, 2010

Unless you request and receive written permission from Super Micro Computer, Inc., you may not copy any part of this document.

Information in this document is subject to change without notice. Other products and companies referred to herein are trademarks or registered trademarks of their respective companies or mark holders.

Copyright © 2010 by Super Micro Computer, Inc.
All rights reserved.

Printed in the United States of America

Preface

About This Manual

This manual is written for professional system integrators and PC technicians. It provides information for the installation and use of the A+ SERVER 2022TG-HTRF/HIBQRF. Installation and maintenance should be performed by experienced technicians only.

The A+ SERVER 2022TG-HTRF/HIBQRF is a high-end server based on the SC827H-R1400BP 2U rackmount chassis and the H8DGT-HF/HIBQF dual processor serverboard. The only difference between the 2022TG-HTRF and 2022TG-HIBQF servers is that the 2022TG-HIBQF server has a QSFP InfiniBand Connector and the the 2022TG-HTRF does not.

Manual Organization

Chapter 1: Introduction

The first chapter provides a checklist of the main components included with the server system and describes the main features of the H8DGT-HF/HIBQF serverboard and the SC827H-R1400BP chassis.

Chapter 2: Server Installation

This chapter describes the steps necessary to install the A+ SERVER 2022TG-HTRF/HIBQRF into a rack and check out the server configuration prior to powering up the system. If your server was ordered without processor and memory components, this chapter will refer you to the appropriate sections of the manual for their installation.

Chapter 3: System Interface

Refer here for details on the system interface, which includes the functions and information provided by the control panel on the chassis as well as other LEDs located throughout the system.

Chapter 4: System Safety

You should thoroughly familiarize yourself with this chapter for a general overview of safety precautions that should be followed when installing and servicing the A+ SERVER 2022TG-HTRF/HIBQRF.

Chapter 5: Advanced Serverboard Setup

Chapter 5 provides detailed information on the H8DGT-HF/HIBQF serverboard, including the locations and functions of connections, headers and jumpers. Refer to this chapter when adding or removing processors or main memory and when reconfiguring the serverboard.

Chapter 6: Advanced Chassis Setup

Refer to Chapter 6 for detailed information on the SC827H-R1400BP server chassis. You should follow the procedures given in this chapter when installing, removing or reconfiguring SATA or peripheral drives and when replacing system power supply units and cooling fans.

Chapter 7: BIOS

The BIOS chapter includes an introduction to BIOS and provides detailed information on running the CMOS Setup Utility.

Appendix A: BIOS Error Beep Codes

Appendix B: System Specifications

Table of Contents

Chapter 1 Introduction

1-1	Overview	1-1
1-2	Serverboard Features	1-2
	Processors	1-2
	Memory	1-2
	Serial ATA	1-2
	PCI Expansion Slots	1-2
	Onboard Controllers/Ports	1-2
	Graphics Controller	1-3
	InfiniBand	1-3
	Other Features	1-3
1-3	Server Chassis Features	1-3
	System Power	1-3
	SATA Subsystem	1-3
	Front Control Panel	1-4
	I/O Backplane	1-4
	Cooling System	1-4
	Air Shrouds	1-4
	Mounting Rails	1-4
1-4	Contacting Supermicro	1-6
1-5	2U Twin ² : System Notes	1-7
	Nodes	1-7
	System Power	1-7
	SATA Backplane/Drives	1-7

Chapter 2 Server Installation

2-1	Overview	2-1
2-2	Unpacking the System	2-1
2-3	Preparing for Setup	2-1
	Choosing a Setup Location	2-1
Warnings and Precautions!	2-2
	Rack Precautions	2-2
	Server Precautions	2-2
	Rack Mounting Considerations	2-3
	Ambient Operating Temperature	2-3
	Reduced Airflow	2-3
	Mechanical Loading	2-3

	Circuit Overloading	2-3
	Reliable Ground	2-3
2-4	Installing the System into a Rack	2-4
	Separating the Sections of the Rack Rails	2-4
	Installing the Inner Rail Extension	2-5
	Outer Rack Rails	2-6
2-5	Checking the Serverboard Setup	2-8
2-6	Checking the Drive Bay Setup	2-10
Chapter 3 System Interface		
3-1	Overview	3-1
4-2	Control Panel Button	3-2
4-3	Control Panel LEDs	3-2
4-4	Drive Carrier LEDs	3-3
	SATA Drives	3-3
	SCSI Drives	3-3
Chapter 4 System Safety		
4-1	Electrical Safety Precautions	4-1
4-2	General Safety Precautions	4-2
4-3	ESD Precautions	4-3
4-4	Operating Precautions	4-3
Chapter 5 Advanced Serverboard Setup		
5-1	Handling the Serverboard	5-1
	Precautions	5-1
	Unpacking	5-2
5-2	Serverboard Installation	5-2
5-3	Connecting Cables	5-2
	Connecting Data Cables	5-3
5-4	I/O Port Connections	5-3
5-5	Processor and Heatsink Installation	5-4
	Installing a Passive CPU Heatsink	5-6
	Removing the Heatsink	5-6
5-6	Installing Memory	5-7
	DIMM Module Population Configuration	5-9
5-7	PCI Expansion Cards	5-10
5-8	Serverboard Details	5-11
5-9	Connector Definitions	5-13
5-10	Jumper Settings	5-16
	Explanation of Jumpers	5-16

5-11 Onboard Indicators..... 5-18

5-12 SATA Ports 5-19

5-13 Enabling SATA RAID..... 5-20

 Serial ATA (SATA)..... 5-20

 Installing the OS/SATA Driver 5-20

 Building a Driver Diskette..... 5-20

 Enabling SATA RAID in the BIOS..... 5-21

 Using the Adaptec RAID Utility 5-22

 Installing the RAID Driver During OS Installation 5-22

5-14 Installing Drivers..... 5-23

 Supero Doctor III..... 5-24

Chapter 6 Advanced Chassis Setup

6-1 Static-Sensitive Devices..... 6-1

 Precautions 6-1

6-2 Control Panel 6-2

 Unpacking 6-2

6-3 Chassis Cover..... 6-3

6-4 Air Guides 6-4

6-5 Checking the Airflow 6-4

 Installation Complete..... 6-4

6-6 System Fans 6-5

 Optional Fan Configurations 6-5

6-7 Removing and Installing the Backplane..... 6-7

 Removing the Backplane 6-7

 Installing the Backplane 6-9

6-8 Installing the Motherboard 6-10

 I/O Shield 6-10

 Permanent and Optional Standoffs..... 6-10

6-9 Adapter Card Replacement..... 6-12

 Add-on Card/Expansion Slot Setup 6-13

6-10 Drive Bay Installation/Removal 6-15

 Accessing the Drive Bays 6-15

6-11 Power Supply 6-19

 Power Supply Replacement..... 6-19

 Power Supply Replacement..... 6-19

Chapter 7 BIOS

7-1	Introduction.....	7-1
	Starting BIOS Setup Utility.....	7-1
	How To Change the Configuration Data.....	7-1
	Starting the Setup Utility.....	7-2
7-2	Main Setup.....	7-2
7-3	Advanced Setup Configurations.....	7-4
4-3	Security Menu.....	7-16
4-4	Boot Menu.....	7-16
4-5	Exit Menu.....	7-17

Appendix A BIOS Error Beep Codes**Appendix B Installing Windows**

B-1	Installing the Windows OS for a RAID System.....	B-1
B-2	Installing the Windows OS for a Non-RAID System.....	B-2

Appendix C System Specifications

Chapter 1

Introduction

1-1 Overview

The A+ SERVER 2022TG-HTRF/HIBQRF is a high-end server comprised of two main subsystems: the SC827H-R1400BP 2U server chassis and the H8DGT-HF/HIBQF dual processor serverboard. Please refer to our web site for information on operating systems that have been certified for use with the system (www.supermicro.com).

In addition to the serverboard and chassis, various hardware components have been included with the 2022TG-HTRF/HIBQRF, as listed below:

- Four (4) Air shrouds for H8 DP (G34), SC827 chassis (MCP-310-82711-0B)
- Four (4) 4-port Adapter cards for backplane (BPN-ADP-4SATA-H8)
- One (1) SAS/SATA Backplane (BPN-SAS-827B)
- Eight (8) 1U Passive CPU heatsinks for AMD Socket G34 (SNK-P0042P)
- Four (4) Riser Cards (RSC-R1U-E16R)
- Twelve (12) Hard Disk Drive Trays (MCP-220-00075-0B)
- One (1) Rack mount rail kit (MCP-290-00053-0N)
- Four (4) 80x38mm 4-pin PWM chassis fans (FAN-0111L4)
- One CD containing manual, drivers and utilities

1-2 Serverboard Features

At the heart of the A+ SERVER 2022TG-HTRF/HIBQRF lies the H8DGT-HF/HIBQF, a dual processor serverboard based on the AMD SR5670/SP5100 Chipset and designed to provide maximum performance. Up to four of these serverboards can be mounted in the SC827 chassis.

The sections below cover the main features of the H8DGT-HF/HIBQF serverboard (see Figure 1-1 for a block diagram of the chipset).

Processors

The H8DGT-HF/HIBQF supports single or dual AMD Opteron 6100 series processors (Socket G34 type). Please refer to the serverboard description pages on our web site for a complete listing of supported processors (www.supermicro.com).

Memory

The H8DGT-HF/HIBQF has sixteen (16) single/dual/tri/quad channel DIMM slots supporting up to 256 GB of DDR3-1333/1066/800 registered ECC or 64GB of DDR3 Unbuffered ECC/non-ECC SDRAM. See Chapter 5 for details.

Serial ATA

A Serial ATA controller is integrated into the AMD SP5100 Chipset to provide a four-port 3 Gb/s SATA subsystem, which is RAID 0 and 1 supported. The SATA drives are hot-swappable units.

Note: The operating system you use must have RAID support to enable the hot-swap capability and RAID function of the SATA drives.

PCI Expansion Slots

The H8DGT-HF/HIBQF has one PCI Express 2.0 x16 expansion slot.

Onboard Controllers/Ports

One Fast UART 16550 compatible serial port and a Mellanox Connect-X InfiniBand (on 2022TG-HIBQRF server only) supporting a single QSFP connector are located on the serverboard. The color-coded I/O ports include one COM port (an additional COM header is located on the serverboard), a VGA (monitor) port, two USB 2.0 ports (additional two internal USB headers and a USB Type A port are included on the serverboard), an IPMI dedicated LAN port and two gigabit Ethernet ports.

Graphics Controller

The H8DGT-HF/HIBQF features an integrated Matrox® G200 graphics controller with 16 MB DDR2 memory.

InfiniBand

The 2022TG-HIBQRF includes a QDR (quad data rate) speed InfiniBand QSFP connector. InfiniBand is a scalable serial communications link intended for connecting processors with high-speed peripherals.

Other Features

Other onboard features that promote system health include onboard voltage monitors, a chassis intrusion header, auto-switching voltage regulators, chassis and CPU overheat sensors, virus protection and BIOS rescue.

1-3 Server Chassis Features

The following is a general outline of the main features of the SC827 server chassis.

System Power

Each SC827 chassis model includes a high-efficiency 80 Plus Gold certified power supply, rated at 1400 Watts plus one redundant backup power supply. In the unlikely event your power supply fails, replacement is simple and can be accomplished without tools.

SATA Subsystem

The SC827 supports up to twelve 3.5" hot-swap SATA drives in trays (3 for each node). These drives are hot-swappable units and are connected to a backplane that provides power and control.

Note: The operating system you use must have RAID support to enable the hot-swap capability of the drives.

Front Control Panel

SC827 models include four front panels on the handles of the chassis which control each of the systems. Each control panel on the A+ SERVER 2022TG-HTRF/HIBQRF provides you with system monitoring and control for one server node. LEDs indicate system power, HDD activity, network activity, system overheat and power supply failure. A main power button and a system reset button are also included.

I/O Backplane

The SC827 is an ATX form factor chassis designed to be used in a 2U rackmount configuration. The SAS827B I/O backplane provides a low-profile add-on card slot, a COM port, a VGA port, two USB 2.0 ports and two gigabit Ethernet ports per node.

For more information regarding the backplane, view the appendices found at the end of this manual.

Cooling System

The SC827 chassis accepts four system fans powered from either backplane or the serverboards. If not powered from the backplane, the SC827B model chassis powers two fans from two motherboards, so that when one of the motherboard drawers is removed, the second motherboard will continue running both fans.

Air Shrouds

The SC827 chassis includes four mylar air shrouds that direct the airflow where cooling is needed on each serverboard. Always use the air shroud included with your chassis on each serverboard.

Mounting Rails

The SC827 includes a set of quick-release rails, and can be placed in a rack for secure storage and use. To setup your rack, follow the step-by-step instructions included in this manual.

**Figure 1-1. AMD SR5670/SP5100 Chipset:
System Block Diagram**

Note: This is a general block diagram. Please see Chapter 5 for details.

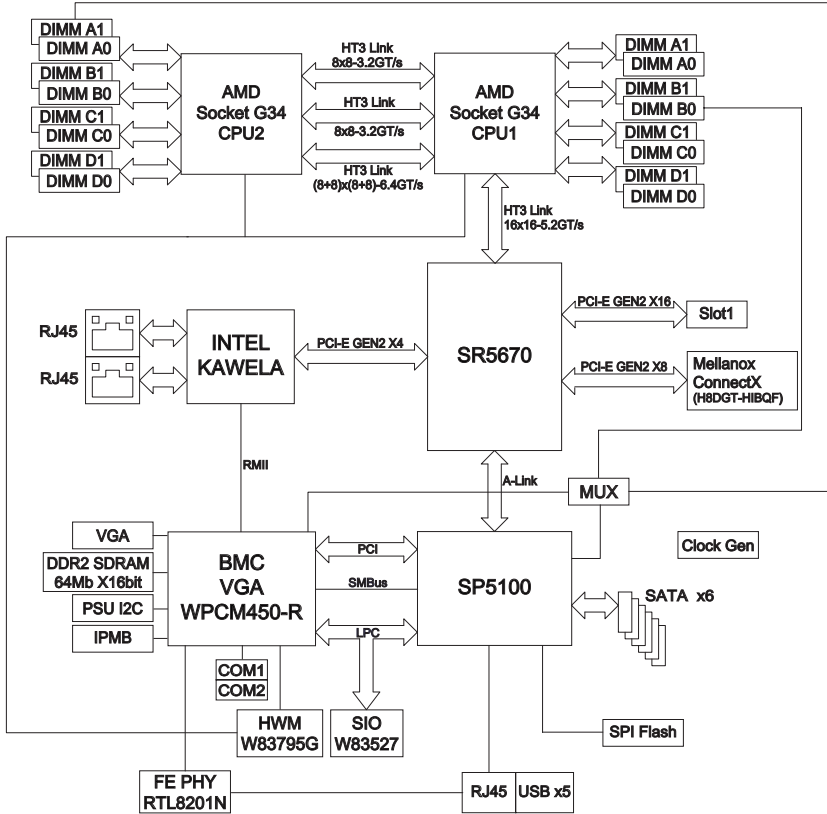

1-4 Contacting Supermicro

Headquarters

Address: Super Micro Computer, Inc.
980 Rock Ave.
San Jose, CA 95131 U.S.A.

Tel: +1 (408) 503-8000

Fax: +1 (408) 503-8008

Email: marketing@supermicro.com (General Information)
support@supermicro.com (Technical Support)

Web Site: www.supermicro.com

Europe

Address: Super Micro Computer B.V.
Het Sterrenbeeld 28, 5215 ML
's-Hertogenbosch, The Netherlands

Tel: +31 (0) 73-6400390

Fax: +31 (0) 73-6416525

Email: sales@supermicro.nl (General Information)
support@supermicro.nl (Technical Support)
rma@supermicro.nl (Customer Support)

Asia-Pacific

Address: Super Micro Computer, Inc.
4F, No. 232-1, Liancheng Rd.
Chung-Ho 235, Taipei County
Taiwan, R.O.C.

Tel: +886-(2) 8226-3990

Fax: +886-(2) 8226-3991

Web Site: www.supermicro.com.tw

Technical Support:

Email: support@supermicro.com.tw

Tel: 886-2-8228-1366, ext.132 or 139

1-5 2U Twin²: System Notes

As a 2U Twin² configuration, the 2022TG-HTRF/HIBQRF is a unique server system. With four system boards incorporated into a single chassis acting as four separate nodes, there are several points you should keep in mind.

Nodes

Each of the four serverboards act as a separate node in the system. As independant nodes, each may be powered off and on without affecting the others. In addition, each node is a hot-swappable unit that may be removed from the rear of the chassis. The nodes are connected to the server backplane by means of an adapter card.

Note: A guide pin is located between the upper and lower nodes on the inner chassis wall. This guide pin also acts as a “stop” when a node is fully installed. If too much force is used when inserting a node this pin may break off. Take care to slowly slide a node in until you hear the “click” of the locking tab seating itself.

System Power

A single 1400W power supply is used to provide the power for all four serverboards. Each serverboard however, can be shut down independently of the other with the power button on its own control panel. As an option, you may add an additional 1400W power supply module for power redundancy.

SATA Backplane/Drives

As a system, the 2022TG-HTRF/HIBQRF supports the use of twelve SATA drives. A single SATA backplane works to apply system-based control for power and fan speed functions, yet at the same time logically connects a set of three SATA drives to each serverboard. Consequently, RAID setup is limited to a three-drive scheme (RAID cannot be spread across all twelve drives). See the Drive Bay Installation/Removal section in Chapter 6 for the logical hard drive and node configuration.

Notes

Chapter 2

Server Installation

2-1 Overview

This chapter provides a quick setup checklist to get your A+ SERVER 2022TG-HTRF/HIBQRF up and running. Following these steps in the order given should enable you to have the system operational within a minimum amount of time. This quick setup assumes that your system has come to you with the processors and memory preinstalled. If your system is not already fully integrated with a serverboard, processors, system memory etc., please turn to the chapter or section noted in each step for details on installing specific components.

2-2 Unpacking the System

You should inspect the box the A+ SERVER 2022TG-HTRF/HIBQRF was shipped in and note if it was damaged in any way. If the server itself shows damage you should file a damage claim with the carrier who delivered it.

Decide on a suitable location for the rack unit that will hold the A+ SERVER 2022TG-HTRF/HIBQRF. It should be situated in a clean, dust-free area that is well ventilated. Avoid areas where heat, electrical noise and electromagnetic fields are generated. You will also need it placed near a grounded power outlet. Read the Rack and Server Precautions in the next section.

2-3 Preparing for Setup

The box the A+ SERVER 2022TG-HTRF/HIBQRF was shipped in should include two sets of rail assemblies, two rail mounting brackets and the mounting screws you will need to install the system into the rack. Follow the steps in the order given to complete the installation process in a minimum amount of time. Please read this section in its entirety before you begin the installation procedure outlined in the sections that follow.

Choosing a Setup Location

- Leave enough clearance in front of the rack to enable you to open the front door completely (~25 inches) and approximately 30 inches of clearance in the back of the rack to allow for sufficient airflow and ease in servicing.

- This product is for installation only in a Restricted Access Location (dedicated equipment rooms, service closets and the like).
- This product is not suitable for use with visual display work place devices according to §2 of the the German Ordinance for Work with Visual Display Units.



Warnings and Precautions!



Rack Precautions

- Ensure that the leveling jacks on the bottom of the rack are fully extended to the floor with the full weight of the rack resting on them.
- In single rack installation, stabilizers should be attached to the rack. In multiple rack installations, the racks should be coupled together.
- Always make sure the rack is stable before extending a component from the rack.
- You should extend only one component at a time - extending two or more simultaneously may cause the rack to become unstable.

Server Precautions

- Review the electrical and general safety precautions in Chapter 4.
- Determine the placement of each component in the rack *before* you install the rails.
- Install the heaviest server components on the bottom of the rack first, and then work up.
- Use a regulating uninterruptible power supply (UPS) to protect the server from power surges, voltage spikes and to keep your system operating in case of a power failure.
- Allow any hot plug drives and power supply modules to cool before touching them.
- Always keep the rack's front door and all panels and components on the servers closed when not servicing to maintain proper cooling.

Rack Mounting Considerations

Ambient Operating Temperature

If installed in a closed or multi-unit rack assembly, the ambient operating temperature of the rack environment may be greater than the ambient temperature of the room. Therefore, consideration should be given to installing the equipment in an environment compatible with the manufacturer's maximum rated ambient temperature (T_{mra}).

Reduced Airflow

Equipment should be mounted into a rack so that the amount of airflow required for safe operation is not compromised.

Mechanical Loading

Equipment should be mounted into a rack so that a hazardous condition does not arise due to uneven mechanical loading.

Circuit Overloading

Consideration should be given to the connection of the equipment to the power supply circuitry and the effect that any possible overloading of circuits might have on overcurrent protection and power supply wiring. Appropriate consideration of equipment nameplate ratings should be used when addressing this concern.

Reliable Ground

A reliable ground must be maintained at all times. To ensure this, the rack itself should be grounded. Particular attention should be given to power supply connections other than the direct connections to the branch circuit (i.e. the use of power strips, etc.).

2-4 Installing the System into a Rack

This section provides information on installing the SC827 chassis into a rack unit with the quick-release rails provided. There are a variety of rack units on the market, which may mean the assembly procedure will differ slightly. You should also refer to the installation instructions that came with the rack unit you are using.

NOTE: This rail will fit a rack between 26" and 33.5" deep.

Separating the Sections of the Rack Rails

The chassis package includes two rail assemblies in the rack mounting kit. Each assembly consists of two sections: an inner fixed chassis rail that secures directly to the server chassis and an outer fixed rack rail that secures directly to the rack itself.

Figure 2-1: Separating the Rack Rails

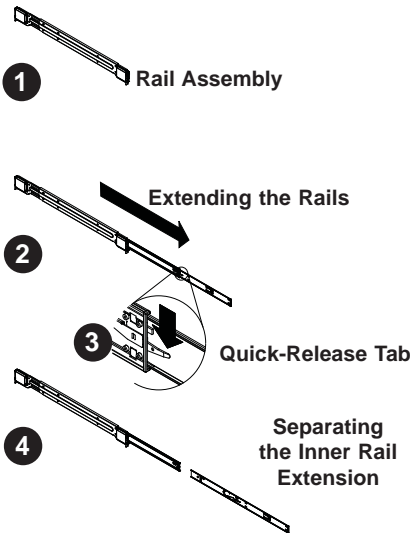

Separating the Inner and Outer Rails

1. Locate the rail assembly in the chassis packaging.
2. Extend the rail assembly by pulling it outward.
3. Press the quick-release tab.
4. Separate the inner rail extension from the outer rail assembly.

Figure 2-2: Installing the Inner Rail Extensions

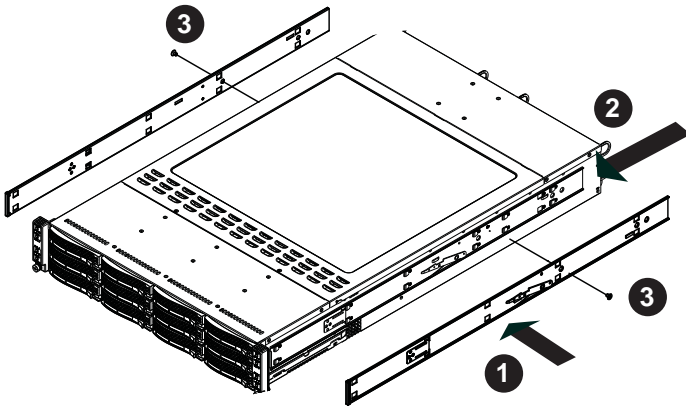

Installing the Inner Rail Extension

The SC827 chassis includes a set of inner rails in two sections: inner rails and inner rail extensions. The inner rails are pre-attached to the chassis, and do not interfere with normal use of the chassis if you decide not to use a server rack. The inner rail extension is attached to the inner rail to mount the chassis in the rack.

Installing the Inner Rails

1. Place the inner rail extensions on the side of the chassis aligning the hooks of the chassis with the rail extension holes. Make sure the extension faces "outward" just like the pre-attached inner rail.
2. Slide the extension toward the front of the chassis.
3. Secure the chassis with 2 screws as illustrated. Repeat steps for the other inner rail extension.

Figure 2-3. Assembling the Outer Rails

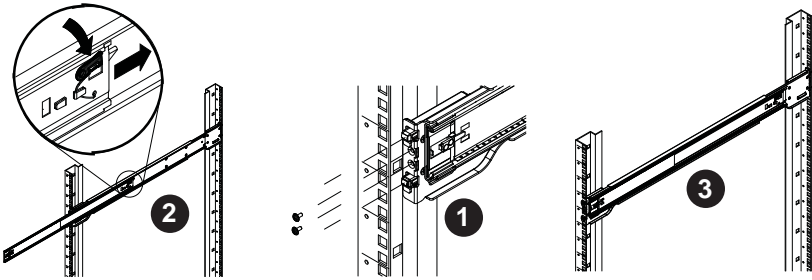

Outer Rack Rails

Outer rails attach to the rack and hold the chassis in place. The outer rails for the SC827 chassis extend between 30 inches and 33 inches.

Installing the Outer Rails to the Rack

1. Secure the back end of the outer rail to the rack, using the screws provided.
2. Press the button where the two outer rails are joined to retract the smaller outer rail.
3. Hang the hooks of the rails onto the rack holes and if desired, use screws to secure the front of the outer rail onto the rack.
4. Repeat steps 1-3 for the remaining outer rail.

Figure 2-4: Installing the Rack Rails

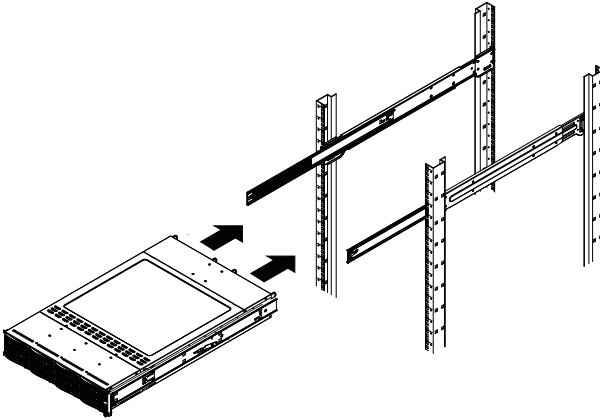

Installing the Chassis into a Rack

1. Extend the outer rails as illustrated above.
2. Align the inner rails of the chassis with the outer rails on the rack.
3. Slide the inner rails into the outer rails, keeping the pressure even on both sides. When the chassis has been pushed completely into the rack, it should click into the locked position.
4. Optional screws may be used to secure the to hold the front of the chassis to the rack.

2-5 Checking the Serverboard Setup

After you install the 2022TG-HTRF/HIBQRF in the rack, you will need to open the unit to make sure the serverboard is properly installed and all the connections have been made.

Accessing the inside of the System

Before operating the server for the first time, it is important to remove the protective film covering the top of the chassis, in order to allow for proper ventilation and cooling.

Removing the Chassis Cover and Protective Film

1. Remove the two screws which secure the top cover onto the chassis as shown above.
2. Lift the top cover up and off the chassis.
3. Peel off the protective film covering the top cover and the top of the chassis
4. Check that all ventilation openings on the top cover and the top of the chassis are clear and unobstructed.

Checking the Components and Setup

1. You may have one or two processors already installed into the serverboard. Each processor needs its own heat sink. See Chapter 5 for instructions on processor and heat sink installation.
2. Your 2022TG-HTRF/HIBQRF server system may have come with system memory already installed. Make sure all DIMMs are fully seated in their slots. For details on adding system memory, refer to Chapter 5.
3. If desired, you can install add-on cards to the system. See Chapter 5 for details on installing PCI add-on cards.
4. Make sure all power and data cables are properly connected and not blocking the chassis airflow. Also make sure that no cables are positioned in front of the fans. See Chapter 5 for details on cable connections.

Figure 2-5. Accessing the Inside of the System

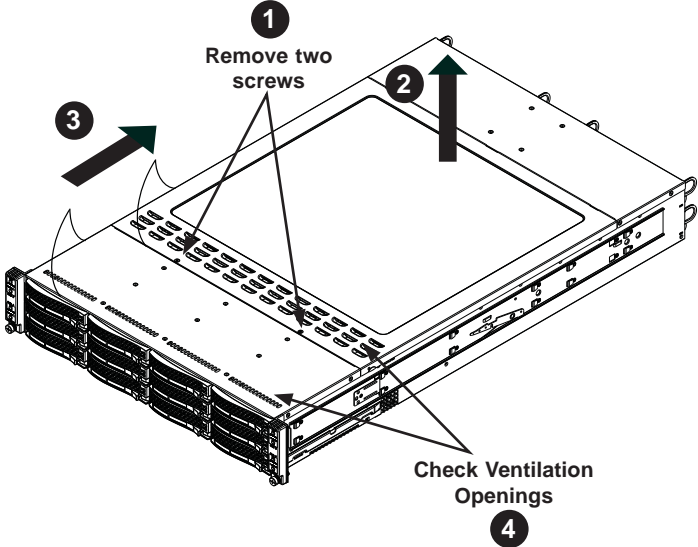

2-6 Checking the Drive Bay Setup

Next, you should check to make sure the peripheral drives and the SATA drives have been properly installed and all connections have been made.

Checking the Drives

1. All drives are accessible from the front of the server. A hard drive can be installed and removed from the front of the chassis without removing the top chassis cover.
2. Depending upon your system's configuration, your system may have one or more drives already installed. If you need to install hard drives, please refer to Chapter 6.

Checking the Airflow

1. Airflow is provided by four hot-swappable 8-cm chassis cooling fans. The system component layout was carefully designed to direct sufficient cooling airflow to the components that generate the most heat.
2. Note that all power and data cables have been routed in such a way that they do not block the airflow generated by the fans.

Providing Power

1. Plug the power cord(s) from the power supply unit(s) into a high-quality power strip that offers protection from electrical noise and power surges. It is recommended that you use an uninterruptible power supply (UPS).
2. Depress the power on button on the front of the chassis.

Chapter 3

System Interface

3-1 Overview

There are several LEDs on the control panel and on the drive carriers to keep you constantly informed of the overall status of the system. SC827 models include four front panels on the handles of the chassis which control each of the systems.

This chapter explains the meanings of all LED indicators and the appropriate response you may need to take.

Figure 3-1: Control Panel

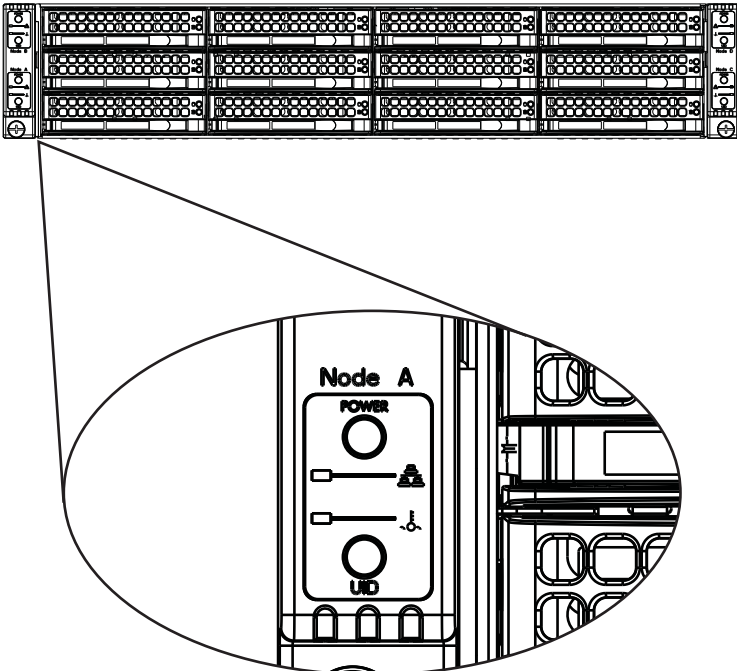

4-2 Control Panel Button



- Power: The main power button on each of the four control panels is used to apply or remove power from the power supply to each of the four systems in the chassis. Turning off system power with this button removes the main power, but keeps standby power supplied to the system. Therefore, you must unplug system before servicing.

4-3 Control Panel LEDs

The four control panels are located on the front handle of the SC827 chassis. Each control panel has three LEDs. These LEDs provide you with critical information related to different parts of the system. This section explains what each LED indicates when illuminated and any corrective action you may need to take.



- Overheat: This LED is illuminated when an overheat condition occurs. A solid red LED indicates an overheat condition in the system. A flashing red LED which flashes in one second intervals indicates a fan failure. A flashing red LED which flashes in four second intervals indicates a power failure. Check the routing of the cables and make sure all fans are present and operating normally. You should also check to make sure that the chassis covers and air shrouds are installed. Finally, verify that the heatsinks are installed properly. This LED will remain flashing or on as long as the temperature is too high or a fan does not function properly.



- NIC1: Indicates network activity on GLAN1 when flashing.

4-4 Drive Carrier LEDs

The server chassis uses SATA drives.

SATA Drives

Each SATA drive carrier has two LEDs.

- Green: Each Serial ATA drive carrier has a green LED. When illuminated, this green LED (on the front of the SATA drive carrier) indicates drive activity. A connection to the SATA backplane enables this LED to blink on and off when that particular drive is being accessed.
- Red: The red LED to indicate an SATA drive failure. If one of the SATA drives fail, you should be notified by your system management software.

SCSI Drives

This chassis does not support SCSI drives at this time.

Notes

Chapter 4

System Safety

4-1 Electrical Safety Precautions



Basic electrical safety precautions should be followed to protect yourself from harm and the A+ SERVER 2022TG-HTRF/HIBQRF from damage:

- Be aware of the locations of the power on/off switch on the chassis as well as the room's emergency power-off switch, disconnection switch or electrical outlet. If an electrical accident occurs, you can then quickly remove power from the system.
- Do not work alone when working with high voltage components.
- Power should always be disconnected from the system when removing or installing main system components, such as the serverboard, memory modules and floppy drive. When disconnecting power, you should first power down the operating system first and then unplug the power cords. The unit has more than one power supply cord. Disconnect two power supply cords before servicing to avoid electrical shock.
- When working around exposed electrical circuits, another person who is familiar with the power-off controls should be nearby to switch off the power if necessary.
- Use only one hand when working with powered-on electrical equipment. This is to avoid making a complete circuit, which will cause electrical shock. Use extreme caution when using metal tools, which can easily damage any electrical components or circuit boards they come into contact with.
- Do not use mats designed to decrease static electrical discharge as protection from electrical shock. Instead, use rubber mats that have been specifically designed as electrical insulators.

- The power supply power cords must include a grounding plug and must be plugged into grounded electrical outlets.
- This product may be connected to an IT power system. In all cases, make sure that the unit is also reliably connected to Earth (ground).
- Serverboard Battery: **CAUTION** - There is a danger of explosion if the onboard CR2032 battery is installed upside down, which will reverse its polarities (see Figure 4-1). This battery must be replaced only with the same or an equivalent type recommended by the manufacturer. Dispose of used batteries according to the manufacturer's instructions.
- Mainboard replaceable soldered-in fuses: Self-resetting PTC (Positive Temperature Coefficient) fuses on the mainboard must be replaced by trained service technicians only. The new fuse must be the same or equivalent as the one replaced. Contact technical support for details and support.

4-2 General Safety Precautions



Follow these rules to ensure general safety:

- Keep the area around the 2022TG-HTRF/HIBQRF clean and free of clutter.
- The 2022TG-HTRF/HIBQRF weighs approximately 85 lbs (38.6kg) when fully loaded. When lifting the system, two people at either end should lift slowly with their feet spread out to distribute the weight. Always keep your back straight and lift with your legs.
- Place the chassis top cover and any system components that have been removed away from the system or on a table so that they won't accidentally be stepped on.
- While working on the system, do not wear loose clothing such as neckties and unbuttoned shirt sleeves, which can come into contact with electrical circuits or be pulled into a cooling fan.
- Remove any jewelry or metal objects from your body, which are excellent metal conductors that can create short circuits and harm you if they come into contact with printed circuit boards or areas where power is present.

- After accessing the inside of the system, close the system back up and secure it to the rack unit with the retention screws after ensuring that all connections have been made.

4-3 ESD Precautions



Electrostatic discharge (ESD) is generated by two objects with different electrical charges coming into contact with each other. An electrical discharge is created to neutralize this difference, which can damage electronic components and printed circuit boards. The following measures are generally sufficient to neutralize this difference before contact is made to protect your equipment from ESD:

- Use a grounded wrist strap designed to prevent static discharge.
- Keep all components and printed circuit boards (PCBs) in their antistatic bags until ready for use.
- Touch a grounded metal object before removing the board from the antistatic bag.
- Do not let components or PCBs come into contact with your clothing, which may retain a charge even if you are wearing a wrist strap.
- Handle a board by its edges only; do not touch its components, peripheral chips, memory modules or contacts.
- When handling chips or modules, avoid touching their pins.
- Put the serverboard and peripherals back into their antistatic bags when not in use.
- For grounding purposes, make sure your computer chassis provides excellent conductivity between the power supply, the case, the mounting fasteners and the serverboard.

4-4 Operating Precautions

Care must be taken to assure that the chassis cover is in place when the 2022TG-HTRF/HIBQRF is operating to assure proper cooling. Out of warranty damage to the system can occur if this practice is not strictly followed.



Figure 4-1. Installing the Onboard CR2032 Battery

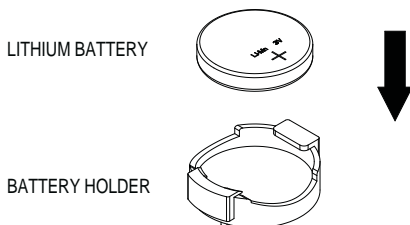

Please handle used batteries carefully. Do not damage the battery in any way; a damaged battery may release hazardous materials into the environment. Do not discard a used battery in the garbage or a public landfill. Please comply with the regulations set up by your local hazardous waste management agency to dispose of your used battery properly.

Chapter 5

Advanced Serverboard Setup

This chapter covers the steps required to install the H8DGT-HF/HIBQF serverboard into the chassis, connect the data and power cables and install add-on cards. All serverboard jumpers and connections are also described. A layout and quick reference chart are included in this chapter for your reference. Remember to completely close the chassis when you have finished working with the serverboard to better cool and protect the system.

5-1 Handling the Serverboard

Electrostatic discharge (ESD) can damage electronic components. To prevent damage to any printed circuit boards (PCBs), it is important to handle them very carefully (see previous chapter). To prevent the serverboard from bending, keep one hand under the center of the board to support it when handling. The following measures are generally sufficient to protect your equipment from electric static discharge.

Precautions

- Use a grounded wrist strap designed to prevent Electrostatic Discharge (ESD).
- Touch a grounded metal object before removing any board from its antistatic bag.
- Handle a board by its edges only; do not touch its components, peripheral chips, memory modules or gold contacts.
- When handling chips or modules, avoid touching their pins.
- Put the serverboard, add-on cards and peripherals back into their antistatic bags when not in use.
- For grounding purposes, make sure your computer chassis provides excellent conductivity between the power supply, the case, the mounting fasteners and the serverboard.

Unpacking

The serverboard is shipped in antistatic packaging to avoid electrical static discharge. When unpacking the board, make sure the person handling it is static protected.

5-2 Serverboard Installation

This section explains the first step of physically mounting the H8DGT-HF/HIBQF into the SC827H-R1400BP chassis. Following the steps in the order given will eliminate the most common problems encountered in such an installation. To remove the serverboard, follow the procedure in reverse order.

Installing to the Chassis

1. Access the inside of the system by removing the screws from the back lip of the top cover of the chassis, then pull the cover off.
2. The H8DGT-HF/HIBQF requires a chassis big enough to support a 6.78" x 16.64" (172 x 423 mm) serverboard, such as Supermicro's SC827H-R1400BP.
3. Make sure that the I/O ports on the serverboard align properly with their respective holes in the I/O shield at the back of the chassis.
4. Carefully mount the serverboard to the serverboard tray by aligning the board holes with the raised metal standoffs that are visible in the chassis.
5. Insert screws into all the mounting holes on your serverboard that line up with the standoffs and tighten until snug (if you screw them in too tight, you might strip the threads). Metal screws provide an electrical contact to the serverboard ground to provide a continuous ground for the system.
6. Finish by replacing the top cover of the chassis.

Warning: To avoid damaging the motherboard and its components, do not apply any force greater than 8 lbs. per square inch when installing a screw into a mounting hole.

5-3 Connecting Cables

Now that the serverboard is installed, the next step is to connect the cables to the board. These include the data cables for the peripherals and control panel and the power cables.

Connecting Data Cables

The H8DGT-HF/HIBQF is a cableless serverboard that does not require control or data cables connected to it in order to function. Use the JP3 Adapter card connector slot to provide front access to the power supply, serial ATA and Front Panel Control connections for the H8DGT series motherboard. Plug an Adapter card into this connector to use the functions indicated above. This header is designed specifically for a Supermicro-proprietary adapter card.

5-4 I/O Port Connections

The I/O ports are color coded in conformance with the PC99 specification to make setting up your system easier. See Figure 5-1 below for the colors and locations of the various I/O ports.

Figure 5-1. I/O Port Locations and Definitions

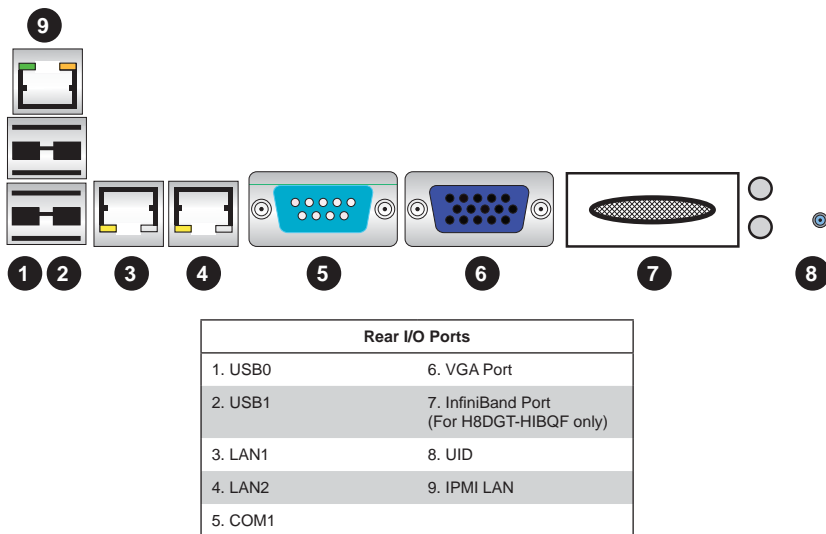

5-5 Processor and Heatsink Installation



When handling the processor, avoid placing direct pressure on the label area of the fan. Also, do not place the serverboard on a conductive surface, which can damage the BIOS battery and prevent the system from booting up.

Notes:

- Always connect the power cord last and always remove it before adding, removing or changing any hardware components. Make sure that you install the processor into the CPU socket before you install the CPU heatsink.
- If you buy a CPU separately, make sure that you use an Intel-certified multi-directional heatsink only.
- Make sure to install the serverboard into the chassis before you install the CPU heatsinks.
- When receiving a serverboard without a processor pre-installed, make sure that the plastic CPU socket cap is in place and none of the socket pins are bent; otherwise, contact your retailer immediately.
- Refer to the Supermicro web site for updates on CPU support.

Installing the Processors

1. Begin by removing the cover plate that protects the CPU. Lift the lever on the CPU socket until it points straight up.



2. With the lever raised, lift open the silver CPU retention plate.



3. Use your thumb and your index finger to hold the CPU. Locate and align pin 1 of the CPU socket with pin 1 of the CPU. Both are marked with a triangle.
4. Align pin 1 of the CPU with pin 1 of the socket. Once aligned, carefully place the CPU into the socket. *Do not drop the CPU on the socket, move the CPU horizontally or vertically or rub the CPU against the socket or against any pins of the socket, which may damage the CPU and/or the socket.*
5. With the CPU inserted into the socket, inspect the four corners of the CPU to make sure that it is properly installed and flush with the socket. Then, gently lower the silver CPU retention plate into place.
6. Carefully press the CPU socket lever down until it locks into its retention tab. For a dual-CPU system, repeat these steps to install another CPU into the CPU#2 socket.



Triangle



Note: in single and dual-CPU configurations, memory must be installed in the DIMM slots associated with the installed CPU(s). Memory is limited to a maximum of 32 for single CPU and 64 GB for dual CPU configurations.

Note: see Chapter 6 for details on installing the air shroud.

Installing a Passive CPU Heatsink

1. Do not apply any thermal grease to the heatsink or the CPU die -- the required amount has already been applied.
2. Place the heatsink directly on top of the CPU so that the heat sink screws are aligned with the mounting holes on the back plate.
3. Make sure the screwdriver torque setting is no more than 5.0 Kgf-cm (4.3 lbf-in) and keep the heat sink direction vertical.
4. Tighten each screw a few turns at a time while alternating between the two until fully tightened.

Figure 5-2. SNK-0042P Heatsink

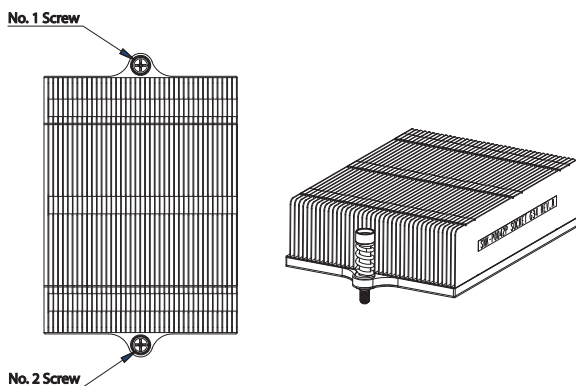

Removing the Heatsink



Warning: We do not recommend removing the CPU or the heatsink. However, if you do need to remove the heatsink, please follow the instructions below to prevent damage to the CPU or other components.

1. Unscrew the heatsink screws from the motherboard a few turns at a time, alternating between the two until the screws can be removed.
2. Gently wriggle the heatsink to loosen it from the CPU. (Do not use excessive force when wriggling the heatsink!)
3. Once the CPU is loose, remove it from the CPU socket.
4. Clean the surface of the CPU and the heatsink, removing the used thermal grease. Reapply the proper amount of thermal grease on the surface before re-installing the CPU and the heatsink.

5-6 Installing Memory



CAUTION! Exercise extreme care when installing or removing DIMM modules to prevent any possible damage.

Installing Memory

1. Insert each memory module vertically into its slot, paying attention to the notch along the bottom of the module to prevent inserting the module incorrectly (see Figure 2-1).
2. Install to slots CPU1/DIMM1A and CPU1/DIMM1B first, then to CPU1/DIMM2A and CPU1/DIMM2B, etc. Always install in pairs and in the numerical order of the DIMM slots. See support information below.
3. Gently press down on the memory module until it snaps into place.
4. With two CPUs installed, repeat step 2 to populate the CPU2 DIMM slots. Always install pairs of DIMMs to both CPU DIMM slots for more efficient operation.

Note: 1 GB, 2 GB, 4 GB, 8 GB and 16 GB memory modules are supported. It is highly recommended that you remove the power cord from the system before installing or changing memory modules. Please refer to our web site for memory that has been tested on the H8DGT-H/HF/HIBQ/HIBQF serverboard.

Support

The H8DGT-HF/HIBQF serverboard supports single/dual/tri/quad-channel, DDR3-1333/1066/800 registered ECC/Unbuffered ECC/non-ECC SDRAM. Only interleaved memory is supported, so you must populate two DIMM slots at a time (see procedure above).

Populating two adjacent slots at a time with memory modules of the same size and type will result in interleaved (128-bit) memory, which is faster than non-interleaved (64-bit) memory.

Maximum Memory

Maximum memory for the H8DGT-HF/HIBQF serverboard is 256 GB of DDR3-1333/1066/800 registered ECC or 64GB of DDR3 Unbuffered ECC/non-ECC SDRAM.

Figure 5-3. DIMM Installation

To Install: Insert module vertically and press down until it snaps into place. Pay attention to the alignment notch at the bottom.

To Remove: Use your thumbs to gently push the release tabs near both ends of the module. This should release it from the slot.

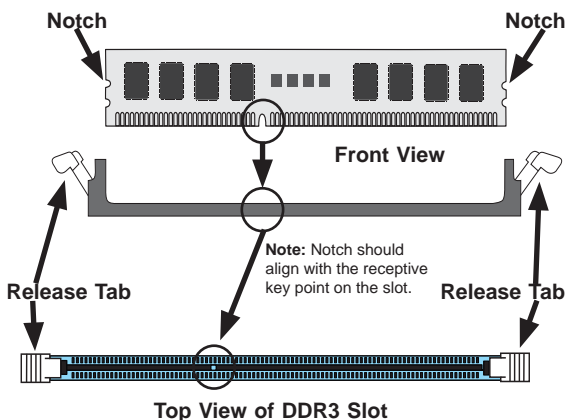

Memory Population for Optimal Performance -For a Motherboard with One CPU (CPU1) Installed									
# DIMMS	CPU	Branch 0		Branch 1		Branch 2		Branch 3	
2 DIMMs	CPU1	P1-1A		P1-2A					
4 DIMMs	CPU1	P1-1A		P1-2A		P1-3A		P1-4A	
8 DIMMs	CPU1	P1-1A	P1-1B	P1-2A	P1-2B	P1-3A	P1-3B	P1-4A	P1-4B

Memory Population for Optimal Performance -For a Motherboard with Two CPUs (CPU1 & CPU2) Installed									
# DIMMS	CPU	Branch 0		Branch 1		Branch 2		Branch 3	
4 DIMMs	CPU1	P1-1A		P1-2A					
	CPU2	P2-1A		P2-2A					
8 DIMMs	CPU1	P1-1A		P1-2A		P1-3A		P1-4A	
	CPU2	P2-1A		P2-2A		P2-3A		P2-4A	
16 DIMMs	CPU1	P1-1A	P1-1B	P1-2A	P1-2B	P1-3A	P1-3B	P1-4A	P1-4B
	CPU2	P2-1A	P2-1B	P2-2A	P2-2B	P2-3A	P2-3B	P2-4A	P2-4B

DIMM Module Population Configuration

For memory to work properly, follow the tables below for memory installation:

DIMM Population Table				
DIMM Slots per Channel	DIMMs Populated per Channel	DIMM Type (Reg.= Registered)	Speeds (in MHz)	Ranks per DIMM (any combination; SR=Single Rank, DR=Dual Rank, QR=Quad Rank)
2	1	Reg. DDR3 ECC	1066,1333	SR or DR
2	1	Reg. DDR3 ECC	1066,1333	QR
2	2	Reg. DDR3 ECC	1066	Mixing SR, DR, QR
2	1	Unb. DDR3 ECC	1066,1333	SR or DR
2	2	Unb. DDR3 ECC	1066,1333	Mixing SR, DR

Note 1: Due to OS limitations, some operating systems may not show more than 4 GB of memory.

Note 2: Due to memory allocation to system devices, the amount of memory that remains available for operational use will be reduced when 4 GB of RAM is used. The reduction in memory availability is disproportional.

Possible System Memory Allocation & Availability		
System Device	Size	Physical Memory Available (4 GB Total System Memory)
Firmware Hub flash memory (System BIOS)	1 MB	3.99 GB
Local APIC	4 KB	3.99 GB
Area Reserved for the chipset	2 MB	3.99 GB
I/O APIC (4 Kbytes)	4 KB	3.99 GB
PCI Enumeration Area 1	256 MB	3.76 GB
PCI Express (256 MB)	256 MB	3.51 GB
PCI Enumeration Area 2 (if needed) -Aligned on 256-M boundary-	512 MB	3.01 GB
VGA Memory	16 MB	2.85 GB
TSEG	1 MB	2.84 GB
Memory available for the OS & other applications		2.84 GB

5-7 PCI Expansion Cards

The 2022TG-HTRF/HIBQRF includes a preinstalled riser card designed specifically for use in the SC827H-R1400BP 2U rackmount chassis for each H8DGT-HF/HIBQF serverboard. This riser card supports a low-profile PCI Express 2.0 x16 card to fit inside the chassis.

PCI Card Installation

A riser card has already been preinstalled into the serverboard. Perform the following steps to add a PCI add-on card:

1. Remove the PCI slot shield on the chassis by releasing the locking tab.
2. Insert the add-on card into the riser card.
3. Secure the add-on card with the locking tab.

5-8 Serverboard Details

Figure 5-4. H8DGT-HIBQF Motherboard Layout
(not drawn to scale)

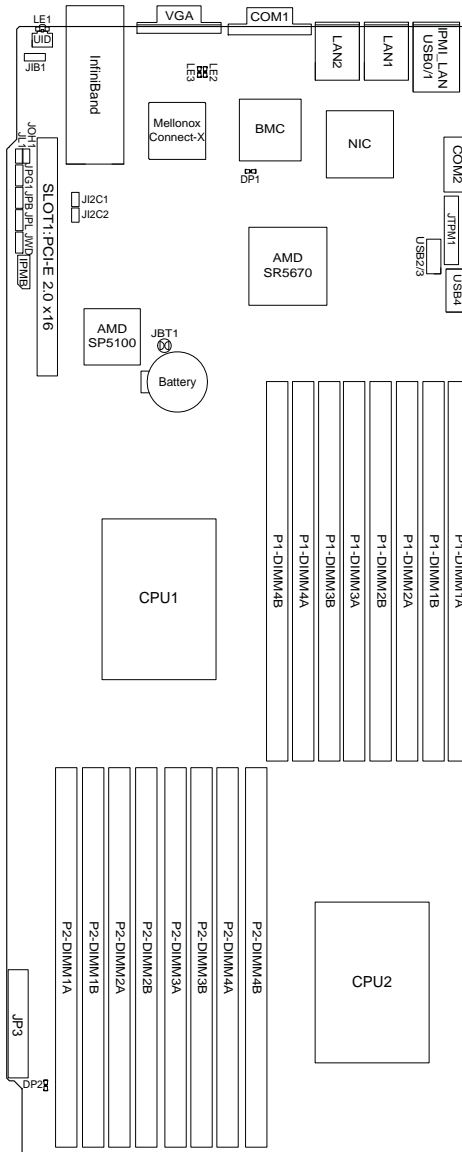

Notes:

Jumpers not indicated are for test purposes only.

H8DGT-HF/HIBQF Quick Reference

Jumper	Description	Default Setting
JBT1	CMOS Clear	(See Section 2-7)
JIB1	InfiniBand Enable/Disable (2022TG-HIBQRF)	Pins 1-2 (Enabled)
JI ² C1/JI ² C2	I ² C to PCI-E Slot Enable/Disable	Both Closed (Enabled)
JPB	BMC Enable/Disable	Pins 1-2 (Enabled)
JPG1	VGA Enable/Disable	Pins 1-2 (Enabled)
JPL1	LAN 1/2 Enable/Disable	Pins 1-2 (Enabled)
JWD	Watch Dog	Pins 1-2 (Reset)

LED**Description**

LAN Ports	LEDs for the LAN Ethernet ports
Dedicated IPMI LAN	LEDs for the dedicated IPMI LAN Ethernet port
LE1	LED for UID Button
LE2	InfiniBand Physical Link LED (Red)
LE3	InfiniBand Logical Link LED (Yellow)
DP1	LED for IPMI activity
DP2	LED for Serverboard Power-On

Connector**Description**

COM1/COM2	COM1 Serial Port/Header
JB1	InfiniBand Connector (2022TG-HIBQRF)
IPMI LAN	Dedicated IPMI LAN Port
IPMB	System Management Bus Header for the IPMI Slot
JL1	Chassis Intrusion Header
JOH1	Overheat Warning Header
JTPM1	Trusted Platform Module Header
JP3	SMC Proprietary Slot for Power, FP Control & SATA connectors
LAN1/2	Gigabit Ethernet (RJ45) Ports
UID	Unit Identifier Button
USB0/1, USB2/3, USB4	Universal Serial Bus (USB) ports, headers and Type-A ports
VGA	VGA Connector

5-9 Connector Definitions

LAN1/2 (Ethernet Ports)

Two Gigabit Ethernet ports (designated LAN1 and LAN2) are located beside the VGA port. Additionally, there is a dedicated LAN port for IPMI beside the two rear USB ports. These Ethernet ports accept RJ45 type cables.



Universal Serial Bus Ports

Two Universal Serial Bus ports (USB 2.0) are located beside the Keyboard and Mouse PS2 ports. One additional Type A port (USB4) are included on the motherboard. See the table on the right for pin definitions.

Universal Serial Bus Ports Pin Definitions (USB0/1, USB4)			
USB0		USB1	
Pin #	Definition	Pin #	Definition
1	+5V	1	+5V
2	PO-	2	PO-
3	PO+	3	PO+
4	Ground	4	Ground

USB Headers

Two USB 2.0 headers (USB2/3) are also included on the motherboard. These may be connected to provide front side access. A USB cable (not included) is needed for the connection. See the table on the right for pin definitions.

Universal Serial Bus Headers Pin Definitions (USB2/3)			
USB2		USB3	
Pin #	Definition	Pin #	Definition
1	+5V	1	+5V
2	PO-	2	PO-
3	PO+	3	PO+
4	Ground	4	Ground
5	Key	5	NC

Note: NC indicates no connection.

Serial Ports

The COM1 serial port is located beside the VGA port. Refer to the motherboard layout for the location of the COM2 header. See the table on the right for pin definitions.

Serial Port Pin Definitions (COM1/COM2)			
Pin #	Definition	Pin #	Definition
1	DCD	6	DSR
2	RXD	7	RTS
3	TXD	8	CTS
4	DTR	9	RI
5	Ground	10	NC

Note: NC indicates no connection.

Chassis Intrusion

A Chassis Intrusion header is located at JL1. Attach the appropriate cable to inform you of a chassis intrusion.

Chassis Intrusion Pin Definitions (JL1)	
Pin#	Definition
1	Battery voltage
2	Intrusion signal

Overheat LED

Connect an LED to the JOH1 header to provide warning of chassis overheating. See the table on the right for pin definitions.

Overheat LED Pin Definitions (JOH1)	
Pin#	Definition
1	3.3V
2	OH Active

IPMB

A System Management Bus header for the IPMI slot is located at IPMB. Connect the appropriate cable here to use the IPMB I2C connection on your system.

IPMB Pin Definitions	
Pin#	Definition
1	Data
2	Ground
3	Clock
4	No Connection

Unit Identifier Button

A Unit Identifier (UID) button is located on the rear of the board. There is another UID button located on the control panel. When you push either UID button, both Rear UID and Front Panel UID Indicators will illuminate. Push either button again to turn off both indicators. These UID indicators provide easy identification of a system unit that may be in need of service.

UID Button Pin Definitions	
Pin#	Definition
1	Ground
2	Ground
3	Button In
4	Ground

Video Connector

A Video (VGA) connector is located below the COM Port on the IO backplane. This connector is used to provide video and CRT display.

Trusted Platform Module Header

This header is used to connect a Trusted Platform Module (TPM), available separately from a third-party vendor. A TPM is a security device that allows encryption and authentication of hard drives, disallowing access if the TPM associated with it is not installed in the system. See the table on the right for pin definitions.

Trusted Platform Module Header Pin Definitions (JTPM1)			
Pin#	Definition	Pin#	Definition
1	LCLK		GND
3	LFRAME		No Pin
5	LRESET		VCC5
7	LAD3		LAD2
9	VCC3		LAD1
11	LAD0		GND
13	RSV0		RSV1
15	SB3V		SERIRQ
17	GND		CLKRUN
19	LPCPD		RSV2

JP3 Adapter Card Connector

JP3 Adapter card connector slot provides front access to the power supply, serial ATA and Front Panel Control connections for the H8DGT series motherboards. Plug an Adapter card into this connector to use the functions indicated above. This connector is designed specifically for a Supermicro-proprietary adapter card.

InfiniBand Connector (2022TG-HIBQRF only)

The H8DGT-HIBQF serverboard includes a single QDR (quad data rate) speed InfiniBand QSFP connector located at JB1 on the serverboard.

The JIB1 jumper must be enabled to use the InfiniBand connector on the serverboard (see section 5-10). LED indicators on the board indicate use and activity on the InfiniBand connector (see section 5-11 for details).

5-10 Jumper Settings

Explanation of Jumpers

To modify the operation of the motherboard, jumpers can be used to choose between optional settings. Jumpers create shorts between two pins to change the function of the connector. Pin 1 is identified with a square solder pad on the printed circuit board. See the diagram at right for an example of jumping pins 1 and 2. Refer to the motherboard layout page for jumper locations.

Note: On two-pin jumpers, "Closed" means the jumper is on and "Open" means the jumper is off the pins.

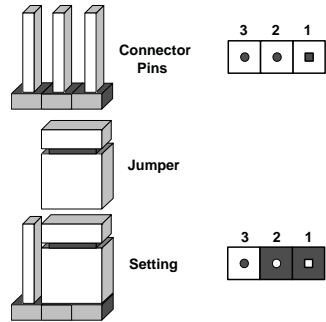

JBT1 contact pads

CMOS Clear

JBT1 is used to clear CMOS, which will also clear any passwords. Instead of pins, this jumper consists of contact pads to prevent accidentally clearing the contents of CMOS.

To Clear CMOS

1. First power down the system and unplug the power cord(s).
2. With the power disconnected, short the CMOS pads with a metal object such as a small screwdriver.
3. Remove the screwdriver (or shorting device).
4. Reconnect the power cord(s) and power on the system.

Note: Do not use the PW_ON connector to clear CMOS.

InfiniBand Enable/Disable (2022TG-HIBQRF only)

The JIB1 jumper allows you to enable or disable the InfiniBand connector. The default position is on pins 1 and 2 to enable the InfiniBand connector. See the table on the right for jumper settings.

InfiniBand Connector Enable/Disable Jumper Settings (JPG1)	
Jumper Setting	Definition
Pins 1-2	Enabled
Pins 2-3	Disabled

I²C to PCI-Express Slot

J1²C1/J1²C2 allows you to enable the I²C bus to communicate with the PCI-Express slot. For the jumpers to work properly, please set both jumpers to the same setting. If enabled, both jumpers must be enabled. If disabled, both jumpers must be disabled. See the table on the right for jumper settings.

I ² C to PCI-Express Slot Jumper Settings (J1 ² C1/J1 ² C2)	
Jumper Setting	Definition
Closed	Enabled
Open	Disabled

Watch Dog Enable/Disable

JWD enables the Watch Dog function, a system monitor that takes action when a software application freezes the system. Jumping pins 1-2 will have WD reboot the system if a program freezes. Jumping pins 2-3 will generate a non-maskable interrupt for the program that has frozen. See the table on the right for jumper settings. Watch Dog must also be enabled in BIOS.

Watch Dog Jumper Settings (JWD)	
Jumper Setting	Definition
Pins 1-2	Reset
Pins 2-3	NMI
Open	Disabled

Note: when Watch Dog is enabled, the user must write their own application software to disable the Watch Dog Timer.

VGA Enable/Disable

JPG1 allows you to enable or disable the VGA port. The default position is on pins 1 and 2 to enable VGA. See the table on the right for jumper settings.

VGA Enable/Disable Jumper Settings (JPG1)	
Jumper Setting	Definition
Pins 1-2	Enabled
Pins 2-3	Disabled

BMC Jumper

JPB is used to enable or disable the BMC (Baseboard Management Control) Chip and the onboard IPMI connection. This jumper is used together with the IPMI settings in the BIOS. The default position is on pins 1 and 2 to Enable BMC. See the table on the right for jumper settings.

BMC Jumper Enable (JPB) Jumper Settings	
Jumper Setting	Definition
Pins 1-2	Enabled (default)
Pins 2-3	Disabled

LAN1/2 Enable/Disable

Change the setting of jumper JPL1 to enable to enable or disable the LAN1 and LAN2 Ethernet ports. See the table on the right for jumper settings. The default setting is enabled.

LAN1/2 En/Disable Jumper Settings (JPL1)	
Jumper Setting	Definition
Pins 1-2	Enabled
Pins 2-3	Disabled

5-11 Onboard Indicators

LAN LEDs

The Ethernet ports (located beside the VGA port) have two LEDs. On each Gb LAN port, one LED blinks to indicate activity while the other may be green, amber or off to indicate the speed of the connection. See the table on the right for the functions associated with the connection speed LED.

LAN LED (Connection Speed Indicator)	
LED Color	Definition
Off	10 MHz
Green	100 MHz
Amber	1 GHz

Dedicated IPMI LAN LEDs

A dedicated IPMI LAN is also included on the H8DGT-H/HF/HIBQ/HIBQF serverboard. The amber LED on the right of the IPMI LAN port indicates activity, while the green LED on the left indicates the speed of the connection. See the table at right for more information.

IPMI LAN Link LED (Left) & Activity LED (Right)		
Color	Status	Definition
Link (Left)	Green: Solid	100 Mb/s
Activity (Right)	Amber: Blinking	Active

IPMI LED

The serverboard contains an IPMI LED (DP1) located near the corner above the PCI-X slots. When this LED is lit, it means a connection is active for the built-in IPMI on the serverboard.

Note: This LED is not installed on non-IPMI boards.

IPMI LED (DP1)	
State	System Status
On	Active connection
Off	No connection

Power LED

DP2 is an Onboard Power LED. When this LED is lit, it means power is present on the serverboard. Be sure to turn off the system and unplug the power cord(s) before removing or installing components.

Power LED (DP2)	
State	System Status
On	Standby power present on motherboard
Off	No power connected

InfiniBand LED Indicators (2022TG-HIBQRF only)

Two InfiniBand LED indicators (LE2/LE3) are located near the InfiniBand port of the H8DGT-HIBQF Serverboard. The green LED (LE2) is the InfiniBand link LED while the yellow LED (LE3) indicates activity. Refer to the tables at the right for details.

InfiniBand LED (LE2) Activity LED		
Color	Status	Definition
Green	Solid	InfiniBand Connected
Off	Off	No Connection

InfiniBand LED (LE3) Activity LED		
Color	Status	Definition
Yellow	Solid	InfiniBand Active
Yellow	Dim	InfiniBand Connected, Activity Idle
Off	Off	No Connection

UID LED (LE1)

A rear UID LED Indicator, located at LE1, works in conjunction with the rear UID switch to provide easy identification for a unit that might be in need of service. Refer to Page 2-13 for further UID details.

5-12 SATA Ports**SATA Ports**

There are no jumpers to configure the SATA ports, which are designated SATA0 through SATA3. See the table on the right for pin definitions.

SATA Port Pin Definitions (I-SATA0~I-SATA5)	
Pin #	Definition
1	Ground
2	TXP
3	TXN
4	Ground
5	RXN
6	RXP
7	Ground

5-13 Enabling SATA RAID

Now that the hardware is set up, you must install the operating system and the SATA RAID drivers, if you wish to use RAID with your SATA drives. The installation procedure differs depending on whether you wish to have the operating system installed on a RAID array or on a separate non-RAID drive. See the instructions below for details.

Serial ATA (SATA)

Serial ATA (SATA) is a physical storage interface that employs a single cable with a minimum of four wires to create a point-to-point connection between devices. This connection is a serial link that supports a SATA transfer rate from 150 MBps. The serial cables used in SATA are thinner than the traditional cables used in Parallel ATA (PATA) and can extend up to one meter in length, compared to only 40 cm for PATA cables. Overall, SATA provides better functionality than PATA.

Installing the OS/SATA Driver

Before installing the OS (operating system) and SATA RAID driver, you must decide if you wish to have the operating system installed as part of a bootable RAID array or installed to a separate non-RAID hard drive. If on a separate drive, you may install the driver either during or after the OS installation. If you wish to have the OS on a SATA RAID array, you must follow the procedure below and install the driver during the OS installation.

Building a Driver Diskette

You must first build a driver diskette from the Supermicro CD-ROM that was included with the system. (You will have to create this disk on a computer that is already running and with the OS installed.)

Building a Driver Diskette

1. Insert the CD into your CD-ROM drive and start the system. A display as shown in Figure 5-7 will appear.
2. Click on the icon labeled "Build Driver Diskettes and Manuals" and follow the instructions to create a floppy disk with the driver on it.
3. Once it's been created, remove the floppy and insert the installation CD for the Windows Operating System you wish to install into the CD-ROM drive of the new system you are about to configure.

Note: You need to have an external USB floppy when building the driver diskette. Window's Vista, Windows 2008 or later Windows OS systems can use a USB stick instead of a floppy.

Enabling SATA RAID in the BIOS

Before installing the Windows Operating System, you must change some settings in BIOS. Boot up the system and hit the key to enter the BIOS Setup Utility. After the Setup Utility loads,

1. Use the arrow keys to move to the Exit menu. Scroll down with the arrow keys to the "Load Optimal Defaults" setting and press <Enter>. Select "OK" to confirm, then <Enter> to load the default settings.
2. Use the arrow keys to move to the "Advanced" menu, then scroll down to "IDE configuration". Once in this submenu, scroll down to "OnChip SATA Type" and choose the "RAID" option (see Figure 5-5).

Figure 5-5. BIOS Setup Screen



3. Hit the <Esc> key twice and scroll to the Exit menu. Select "Save Changes and Exit" and hit <enter>, then hit <Enter> again to verify.

4. After exiting the BIOS Setup Utility, the system will reboot. When prompted during the startup, press the <CTRL+A> key when prompted to run the Adaptec® RAID Utility program (see Figure 5-6).

Using the Adaptec RAID Utility

The Adaptec RAID Utility program is where you can define the drives you want to include in the RAID array and the mode and type of RAID.

Figure 5-6. Adaptec RAID Utility Program Screen

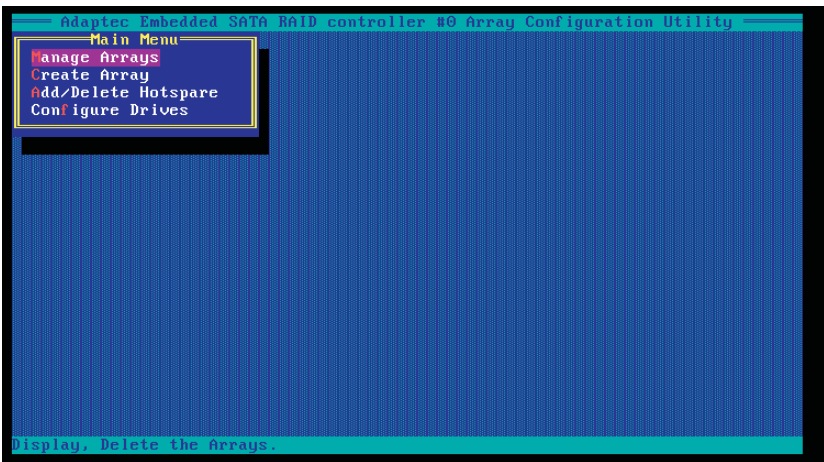

Installing the RAID Driver During OS Installation

You may also use the procedure below to install the RAID driver during the Windows OS installation:

5. With the Windows OS installation CD in the CD-ROM drive, restart the system.
6. When you see the prompt, hit the <F6> key to enter Windows setup.
7. Eventually a blue screen will appear with a message that begins "Windows could not determine the type of one or more storage devices . . ." When you see the screen, hit the <S> key to "Specify Additional Device", then insert the driver diskette you just created into the floppy drive.
8. Highlight "Manufacturer Supplied Hardware Support Disk" and hit the <Enter> key.

9. Highlight the first "Adaptec RAID" driver shown and press the <Enter> key to install it.
10. Press <Enter> again to continue with the Windows setup.

5-14 Installing Drivers

The CD that came bundled with the system contains drivers, some of which must be installed, such as the chipset driver. After inserting this CD into your CD-ROM drive, the display shown in Figure 5-7 should appear. (If this display does not appear, click on the My Computer icon and then on the icon representing your CD-ROM drive. Finally, double click on the S "Setup" icon.)

Click the icons showing a hand writing on paper to view the readme files for each item. Click the computer icons to the right of these items to install each item (from top to the bottom) one at a time. After installing each item, you should reboot the system before moving on to the next item on the list. The bottom icon with a CD on it allows you to view the entire contents of the CD.

Figure 5-7. Driver/Tool Installation Display Screen

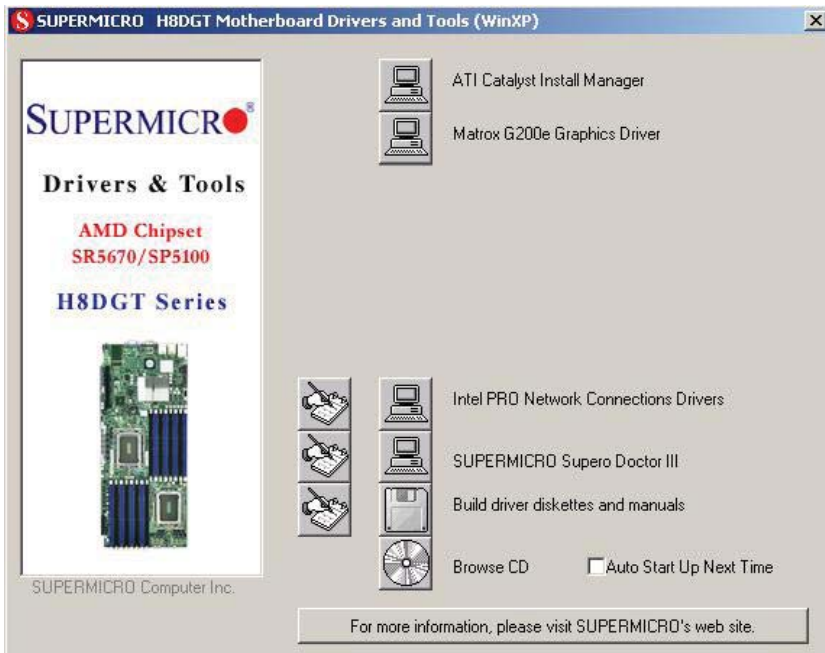

Supero Doctor III

The Supero Doctor III program is a Web base management tool that supports remote management capability. It includes Remote and Local Management tools. The local management is called SD III Client. The Supero Doctor III program included on the CD-ROM that came with your motherboard allows you to monitor the environment and operations of your system. Supero Doctor III displays crucial system information such as CPU temperature, system voltages and fan status. See the Figure below for a display of the Supero Doctor III interface.

Note: The default User Name and Password for SuperDoctor III is ADMIN / ADMIN.

Note: When SuperDoctor III is first installed, it adopts the temperature threshold settings that have been set in BIOS. Any subsequent changes to these thresholds must be made within Super Doctor, as the Super Doctor settings override the BIOS settings. To set the BIOS temperature threshold settings again, you would first need to uninstall SuperDoctor III.

Figure 5-8. Supero Doctor III Interface Display Screen (Health Information)

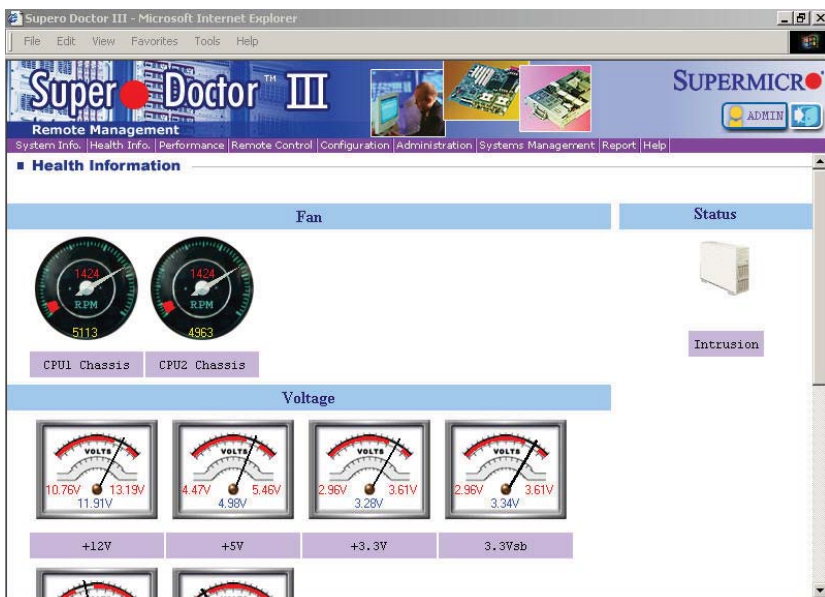



Graceful power control

Supero Doctor III allows a user to inform the OS to reboot or shut down within a specified time (the default is 30 seconds). Before the system reboots or shuts down, it's allowed to cancel the action.

Requirements

Keep Supero SD3Service Daemon running at all times on this system.
Provide TCP/IP connectivity.

Power control

Note: Super Doctor III Software Revision 1.0 can be downloaded from our Web Site at: ftp://ftp.supermicro.com/utility/Supero_Doctor_III/. You can also download the Super Doctor III User's Guide at: <http://www.supermicro.com/PRODUCT/Manuals/SDIII/UserGuide.pdf>. For Linux, we recommend that you use the Supero Doctor II application instead.

Notes

Chapter 6

Advanced Chassis Setup

This chapter covers the steps required to install components and perform maintenance on the SC827H-R1400BP chassis. For component installation, follow the steps in the order given to eliminate the most common problems encountered. If some steps are unnecessary, skip ahead to the step that follows.

Tools Required: The only tool you will need to install components and perform maintenance is a Philips screwdriver.

6-1 Static-Sensitive Devices

Electrostatic discharge (ESD) can damage electronic components. To prevent damage to any printed circuit boards (PCBs), it is important to handle them very carefully. The following measures are generally sufficient to protect your equipment from ESD damage.

Precautions

- Use a grounded wrist strap designed to prevent static discharge.
- Touch a grounded metal object before removing any board from its antistatic bag.
- Handle a board by its edges only; do not touch its components, peripheral chips, memory modules or gold contacts.
- When handling chips or modules, avoid touching their pins.
- Put the serverboard, add-on cards and peripherals back into their antistatic bags when not in use.
- For grounding purposes, make sure your computer chassis provides excellent conductivity between the power supply, the case, the mounting fasteners and the serverboard.

Unpacking

The serverboard is shipped in antistatic packaging to avoid static damage. When unpacking the board, make sure the person handling it is static protected.

Figure 6-1. Front and Rear Chassis Views

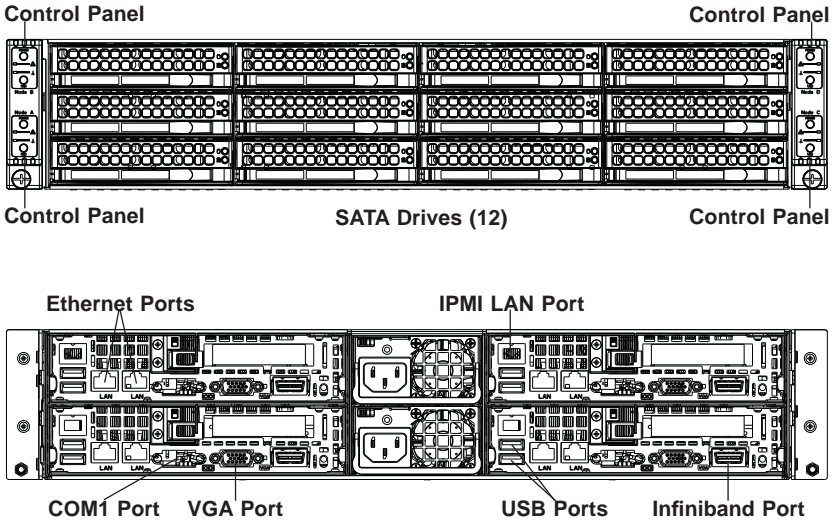

6-2 Control Panel

The control panel (located on the front of the chassis) must be connected to the JF1 connector on the serverboard to provide you with system status indications. A ribbon cable has bundled these wires together to simplify the connection. Connect the cable from JF1 on the serverboard to the Control Panel PCB (printed circuit board). Make sure the red wire plugs into pin 1 on both connectors. Pull all excess cabling out of the airflow path. The LEDs inform you of system status.

See Chapter 3 for details on the LEDs and the control panel buttons. Details on JF1 can be found in Chapter 5.

6-3 Chassis Cover

Before operating the SC827 chassis for the first time, it is important to remove the protective film covering the top of the chassis, in order to allow for proper ventilation and cooling.

Removing the Chassis Cover and Protective Film

1. Remove the two screws which secure the top cover onto the chassis as shown above.
2. Lift the top cover up and off the chassis.
3. Peel off the protective film covering the top cover and the top of the chassis
4. Check that all ventilation openings on the top cover and the top of the chassis are clear and unobstructed.

Figure 6-2. Removing the Chassis Cover

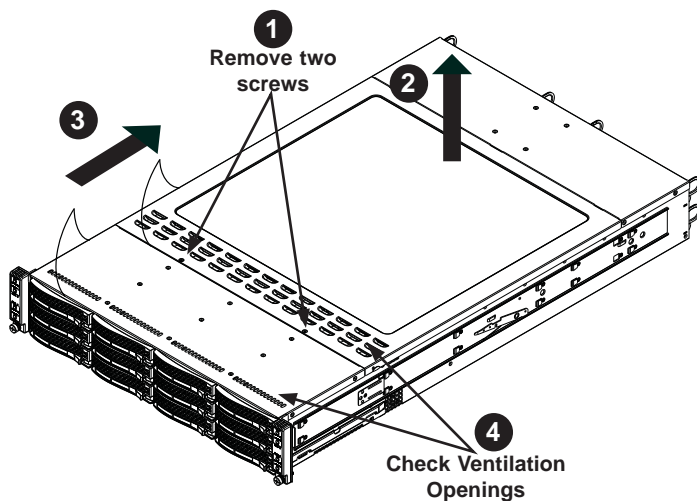

Warning: Except for short periods of time, do NOT operate the server without the cover in place. The chassis cover must be in place to allow proper airflow and prevent overheating.

6-4 Air Guides

The air guides concentrate and maximize air flow in the chassis. These air guides do not require screws to set up, but rather attaches to the serverboard by two tabs on the air guides. The SC827 chassis requires four identical air guides, one in each motherboard drawer. Air guides vary depending upon the motherboard used. See the illustrations below.

Installing an Air Guide

1. Confirm that all four fans are in place and are working properly
2. Place the first air guide into the motherboard drawer. It attaches behind the system fans and attaches by two tabs over the top of the motherboard and its components.
3. Repeat the procedure for the remaining three motherboard drawers.

6-5 Checking the Airflow

Checking Airflow

1. Make sure there are no objects to obstruct airflow in and out of the server. In addition, if you are using a front bezel, make sure the bezel's filter is replaced periodically.
2. Do not operate the server without drives or drive trays in the drive bays. Use only recommended server parts.
3. Make sure no wires or foreign objects obstruct airflow through the chassis. Pull all excess cabling out of the airflow path or use shorter cables.
4. The control panel LEDs inform you of system status. See "Chapter 3: System Interface" for details on the LEDs and the control panel buttons.

Installation Complete

In most cases, the chassis power supply and fans are pre-installed. If you need to install fans or power supplies, continue to the Systems Fan and Power Supply sections of this chapter. If the chassis will be installed into a rack, continue to the next chapter for rack installation instructions.

6-6 System Fans

Four fans provide cooling for the chassis. These fans circulate air through the chassis as a means of lowering the chassis internal temperature. The SC827 system fans are hot-swappable. There is no need to power down the system when replacing fans and new tools are required for installation.

Optional Fan Configurations

The SC827H model chassis is designed so that the default configuration of the system is for each motherboard to control two fans. The fans are hot-swappable. Each motherboard node in the chassis is connected to the backplane through the adapter card, mounted in the motherboard drawer. In the event that one of the motherboard drawers is removed, then the remaining motherboard will operate both fans.

Fan Configurations Options
SC827H Hot-Swappable Default Configuration
Fan A connected to bplane, bplane connected to Node A by adapter card
Fan B connected to bplane, bplane connected to Node B by adapter card
Fan C connected to bplane, bplane connected to Node C by adapter card
Fan D connected to bplane, bplane connected to Node D by adapter card

Figure 6-4. System Fan Placement

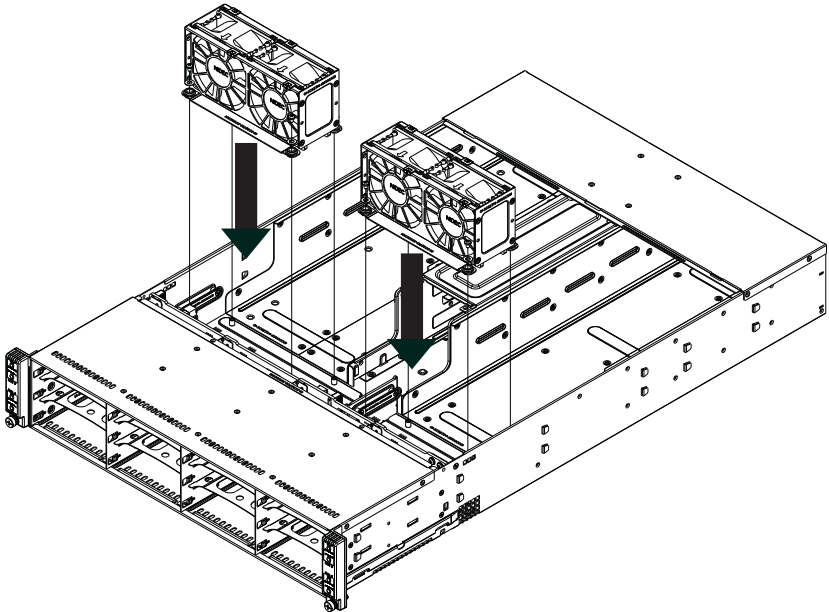

Changing a System Fan

1. If necessary, open the chassis while the power is running to determine which fan has failed. (Never run the server for an extended period of time with the chassis cover open.)
2. Remove the failed fan's power cord from the backplane.
3. Lift the fan housing up and out of the chassis.
4. Push the fan up from the bottom and out of the top of the housing.
5. Place the replacement fan into the vacant space in the housing while making sure the arrows on the top of the fan (indicating air direction) point in the same direction as the arrows on the other fans.
6. Confirm that the fan is working properly before replacing the chassis cover.

Figure 6-5. Replacing a System Fan in the Fan Housing

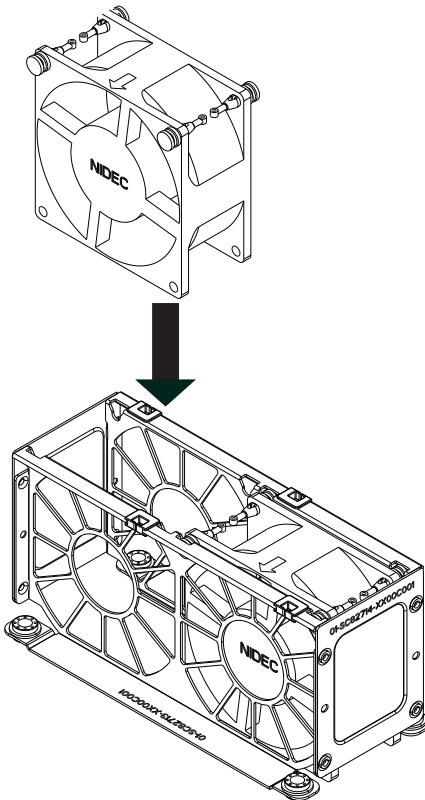

6-7 Removing and Installing the Backplane

The SC827 chassis backplane is located behind the hard drives and in front of the front system fans. In order to change jumper settings on the backplane, it may be necessary to remove the backplane from the chassis.

Removing the Backplane

Removing the Backplane from the Chassis

1. Power down and unplug the system from any power source.
2. Remove the chassis cover.
3. Disconnect the cabling to the backplane.
4. Remove all of the hard drive trays from the front of the chassis.
5. Remove the four upper screws at the top of the backplane, indicated by the arrows below.

Figure 6-6. Removing the Screws at the Top of the Backplane

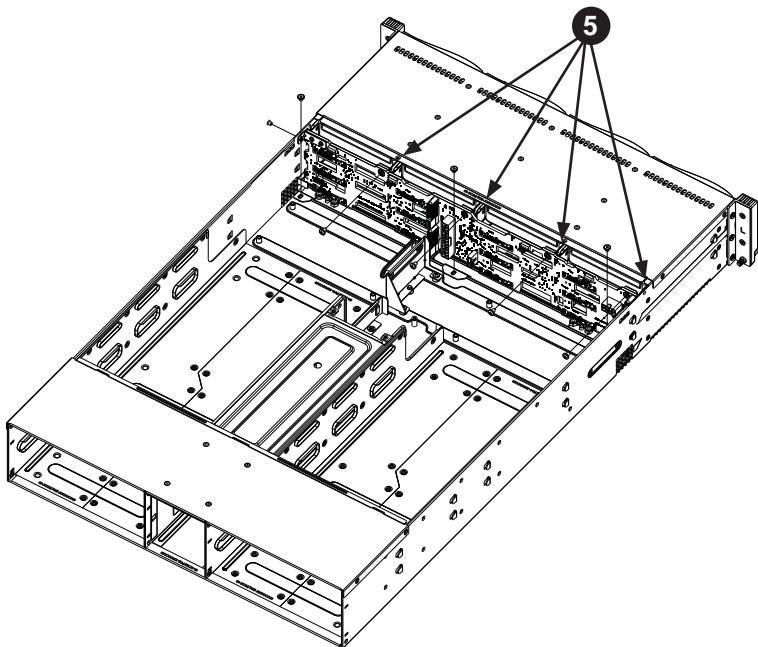

6. Loosen the three screws in the spring bar, located on the floor of the chassis, indicated by the arrows below.

Figure 6-7. Loosening the Spring Bar Screws in the Floor of the Chassis

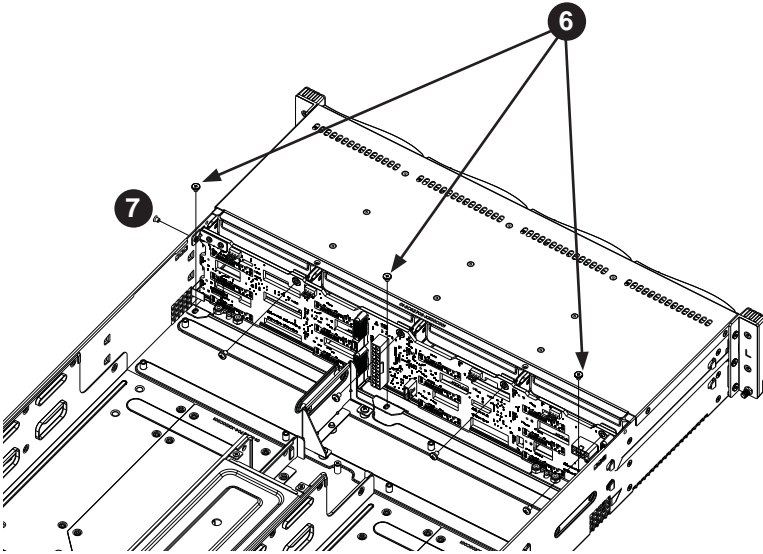

7. Remove the side screw from the side of the chassis.

Figure 6-8. Removing the Backplane from the Chassis

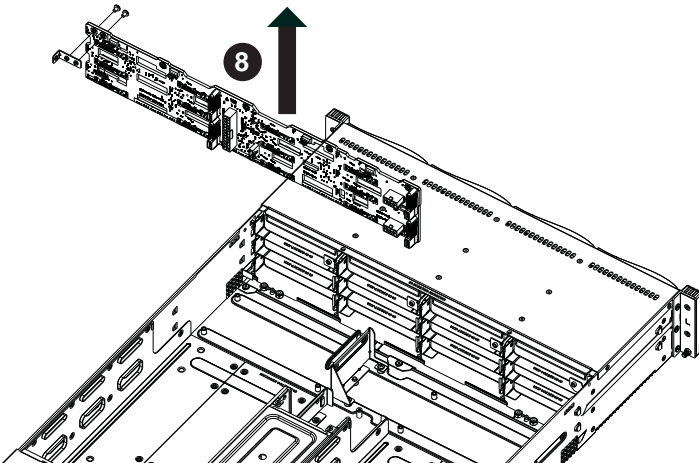

8. Gently ease the backplane up and out of the chassis.

Installing the Backplane

Installing the Backplane into the Chassis

1. Ensure that all of the hard drive trays have been removed from the bays in the front of the chassis and that the spring bar has been loosened as directed in the previous section.
2. Secure the side mounting bracket to the backplane with the two screws provided.
3. Slide the backplane into the chassis at a slight angle, pushing it up against the side of the chassis.
4. Ease the backplane forward, against the front of the chassis. This will aid in the alignment of the mounting holes.
5. Align the mounting holes in the backplane with the holes in the chassis. Replace the four screws at the top of the backplane and the screw on the side of the chassis.
6. Adjust the spring bar, then tighten the spring bar screws in the floor of the chassis.
7. Replace the side screw in the side of the chassis
8. Reconnect all cables and return the hard drive trays to their bays in the front of the chassis.

Figure 6-9. Installing the Backplane

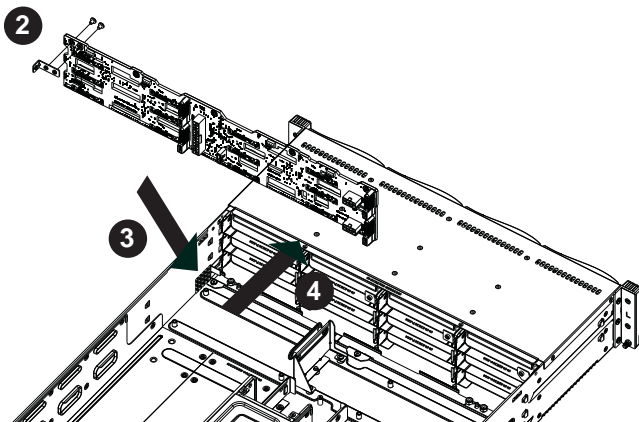

6-8 Installing the Motherboard

I/O Shield

The I/O shield holds the motherboard ports in place. The I/O shield does not require installation.

Figure 6-10. I/O Shield Placement

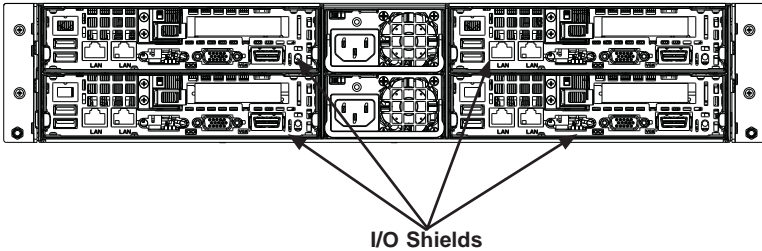

Permanent and Optional Standoffs

Standoffs prevent short circuits by securing space between the motherboard and the chassis surface. The SC827 chassis includes permanent standoffs in locations used by the motherboards. These standoffs accept the rounded Phillips head screws included in the SC827 accessories packaging.

Some motherboards require additional screws for heatsinks, general components and/or non-standard security. Optional standoffs are used for these motherboards.

To use an optional standoff, you must place a hexagon screw through the bottom the chassis and secure the screw with the hexagonal nut (rounded side up).

Depending upon the configuration of the motherboard being used, it is also possible that some of the optional standoffs which are pre-installed in the chassis, may need to be removed.

Installing the Motherboard

1. Review the documentation that came with your motherboard. Become familiar with component placement, requirements, precautions, and cable connections.
2. Pull the motherboard drawer out of the back of the chassis.
3. Remove the add-on card brackets:
 - 3a. Remove screw securing the add-on card bracket to the back of the drawer.

- 3b. Lift the bracket out of the drawer.
- 3c. Repeat this process for the second riser card.
4. Lay the first motherboard in the drawer aligning the standoffs with the motherboard.
5. Secure the motherboard to the drawer using the rounded, Phillips head screws included for this purpose.
6. Repeat steps 3 - 5 for the remaining drawers.
7. Secure the CPU(s), heatsinks, and other components to the motherboard as described in the motherboard documentation.
8. Connect the cables between the motherboard, backplane, chassis, front panel, and power supply, as needed. Also, fans may be temporarily removed to allow access to the backplane ports.
9. Replace the add-on card bracket and secure the bracket with a screw.

Figure 6-11. Installing the Motherboard in the Motherboard Node Drawer

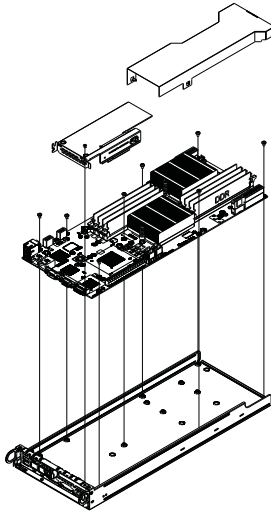

6-9 Adapter Card Replacement

Each motherboard drawer comes equipped with an adapter card which plugs into the backplane. In the unlikely event that the adapter card needs to be replaced, installation requires only a Phillips head screwdriver.

Figure 6-12. Adapter Card Installation

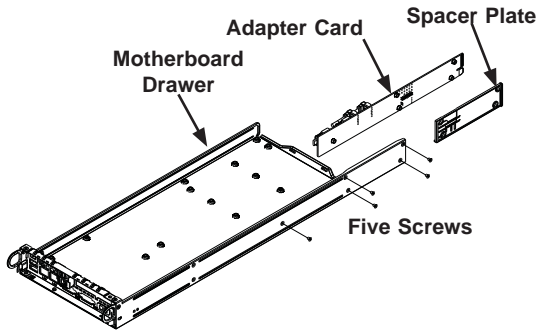

Removing the Adapter Card

1. Disconnect the wiring connecting the adapter card to the motherboard.
2. Remove the motherboard drawer from the chassis.
3. Remove the motherboard from the motherboard drawer by removing the screws securing it to the drawer. Set the screws aside for later use.
4. Remove the five screws securing the adapter card and the spacer plate to the drawer and set them aside for later use.
5. Remove the adapter card and spacer plate from the motherboard drawer.
6. Set the spacer plate aside for later use.

Installing the Adapter Card

1. Place the adapter card and spacer plate in the motherboard drawer, aligning the holes in the spacer and the adapter card with the holes in the motherboard drawer.
2. Secure the adapter card and spacer plate to the motherboard drawer, using the five screws which were previously set aside.
3. Reconnect the wiring from the motherboard to the adapter card.

- Return the motherboard drawer to the closed position in the chassis.

Add-on Card/Expansion Slot Setup

The SC827 chassis includes I/O slots for add-on cards and expansion cards. Each side supports one low profile/half length add-on card for a total of four per chassis, one per drawer.

Installing Add-on Cards

- Disconnect the power supply, lay the chassis on a flat surface, and open the chassis cover.
- Pull open the add-on card slot clip in the rear of the chassis.
- Slide the temporary PCI slot shield toward the slot clip and remove the temporary shield from the chassis.

Figure 6-13. I/O Shield Placement

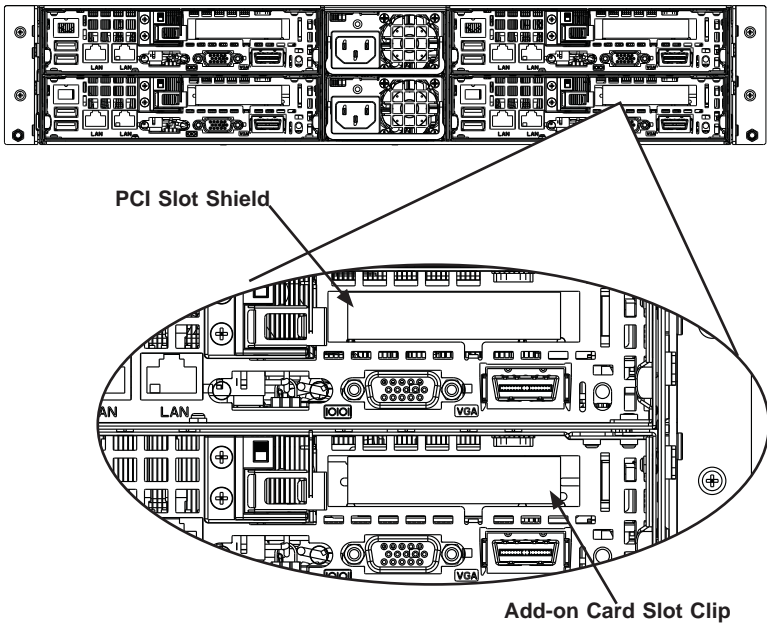

- Connect the add-on card to the riser card.
- Secure the riser card to the motherboard tray using the riser card screw.

- Slide the add-on card bracket into the rear add-on card slot and secure with the add-on card bracket screws.
- Close the add-on card slot clip.

Note: Under normal circumstances, the riser card and add-on card bracket are not separated.

Figure 6-14. Installing the Low Profile Add-On Card

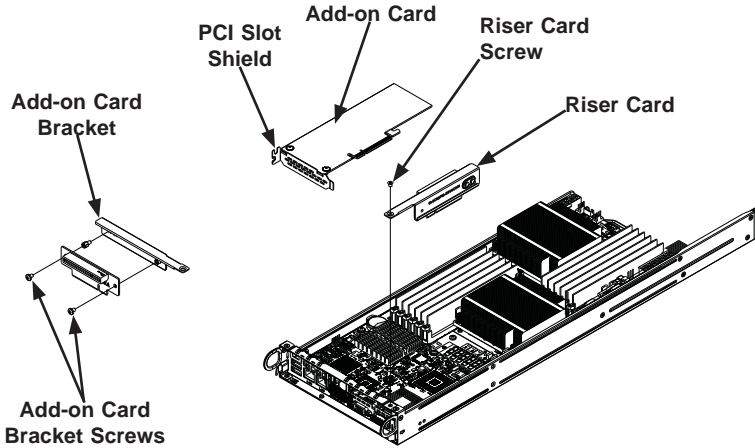

6-10 Drive Bay Installation/Removal

Accessing the Drive Bays

SATA Drives: You do not need to access the inside of the chassis or remove power to replace or swap SATA drives. Proceed to the next step for instructions. You must use standard 1" high, SATA drives in the system.

Note: Refer to the following FTP site for setup guidelines: <ftp://ftp.supermicro.com/driver/SAS/LSI/LSI_SAS_EmbMRAID_SWUG.pdf> and Supermicro's web site for additional information <<http://www.supermicro.com/support/manuals/>>.

The SC827 chassis contains four individual motherboards in separate node drawers. Each motherboard node controls a set of three hard drives. Note that if a motherboard node drawer is pulled out of the chassis, the hard drives associated with that node will power down as well.

Motherboard Drawer Locations in the Chassis	
Motherboard B Controls HDDs B1, B2 and B3	Motherboard D Controls HDDs D1, D2 and D3
Motherboard A Controls HDDs A1, A2 and A3	Motherboard C Controls HDDs C1, C2 and C3

Figure 6-15. Hard Drives and the Corresponding Motherboards

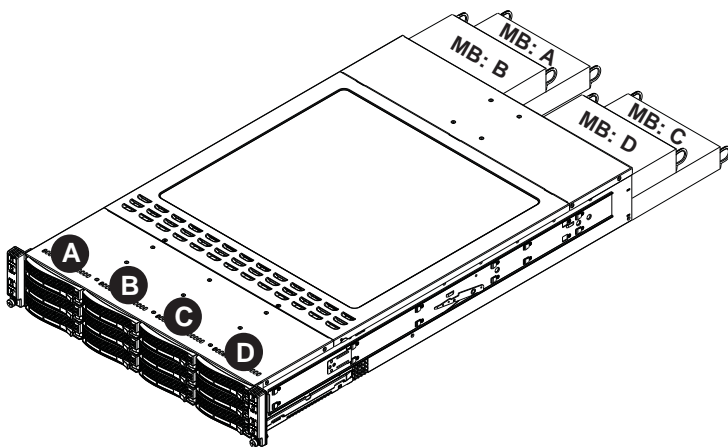

Removing Hard Drive Trays from the Chassis

1. Press the release button on the drive tray. This extends the drive bay handle.
2. Use the handle to pull the drive out of the chassis.

Figure 6-16. Removing Hard Drive

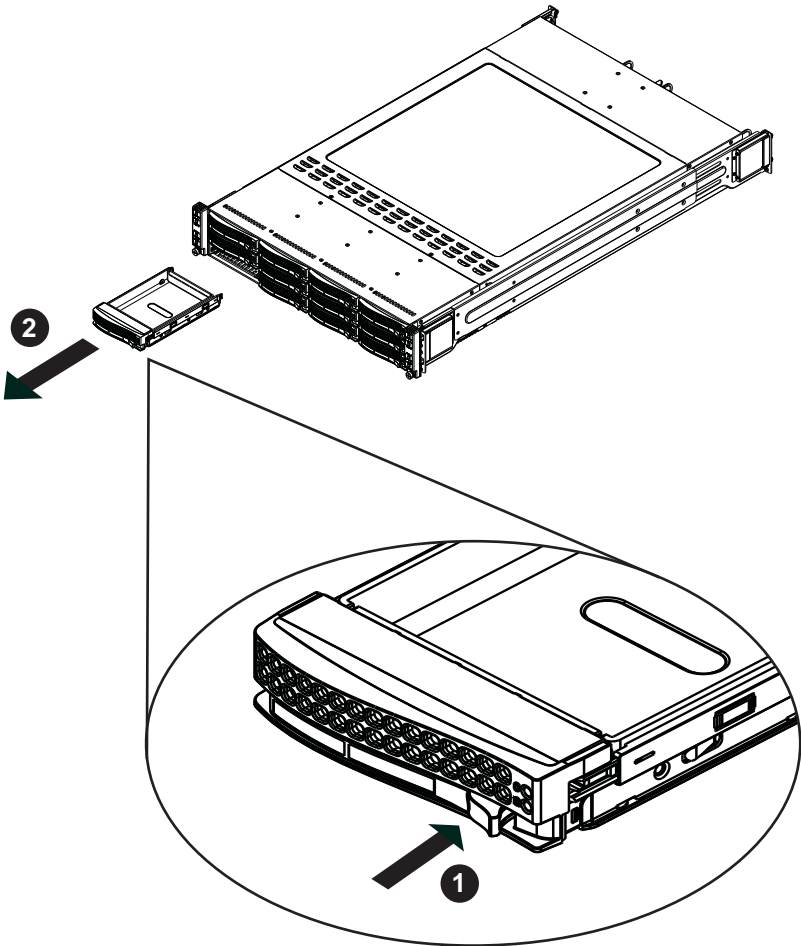
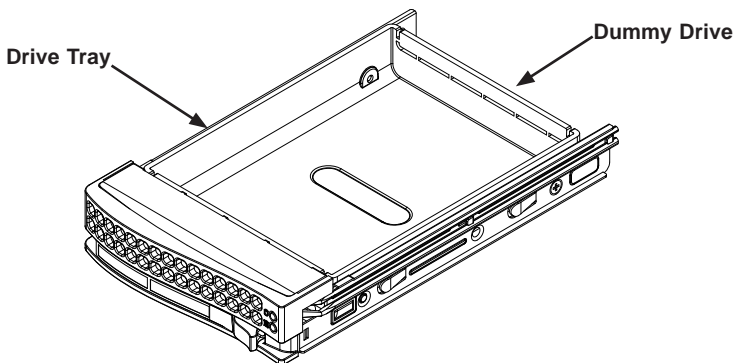

Figure 6-17. Chassis Drive Tray



The drives are mounted in drive carriers to simplify their installation and removal from the chassis. These carriers also help promote proper airflow for the drive bays.



Warning: Except for short periods of time while swapping hard drives, do not operate the server with the hard drives empty.

Figure 6-18. Removing Dummy Drive from Tray

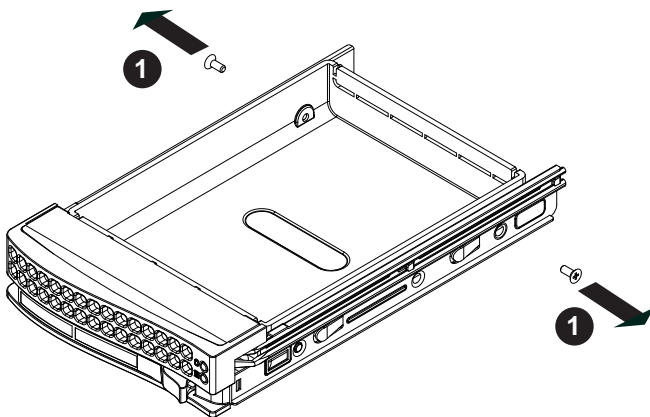

Installing a Drive into the Hard Drive Tray

1. Remove the screws (2) holding connecting the drive tray the carrier.
2. Remove the tray from the carrier.

Figure 6-19. Installing the Hard Drive

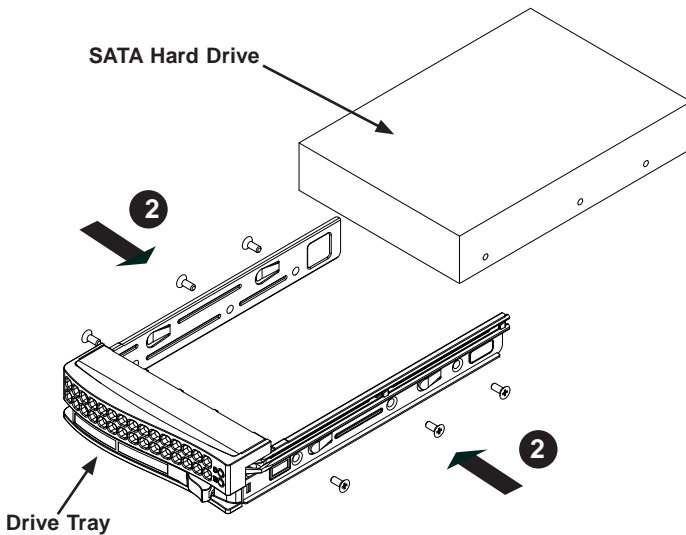

1. Install a new drive into the carrier with the printed circuit board side facing down so that the mounting holes align with those in the carrier.
2. Secure the hard drive by tightening all six (6) screws.
3. Use the open handle to replace the drive tray into the chassis. Make sure the close the drive tray handle.



Warning! Enterprise level hard disk drives are recommended for use in Supermicro chassis and servers. For information on recommended HDDs, visit the Supermicro Web site at <http://www.supermicro.com/products/nfo/storage.cfm>.

6-11 Power Supply

Depending on your chassis model, the SC827 chassis will include two 1200W power supplies. This power supply is auto-switching capable. This enables it to automatically sense and operate at a 100v to 240v input voltage. An amber light will be illuminated on the power supply when the power is off. An illuminated green light indicates that the power supply is operating.

Power Supply Replacement

The SC827 chassis utilizes two redundant power supplies. In the unlikely event that the power supply unit needs to be replaced, one power supply can be removed, without powering down the system. Replacement units can be ordered directly from Supermicro (See the contact information in the Preface of this manual).

Power Supply Replacement

The SC827 chassis utilizes two redundant power supplies. In the unlikely event that the power supply unit needs to be replaced, one power supply can be removed, without powering down the system. Replacement units can be ordered directly from Supermicro (See the contact information in the Preface of this manual).

Changing the Power Supply

1. Power down all four nodes and unplug the power cord.
2. Push the release tab (on the back of the power supply) as illustrated.
3. Pull the power supply out using the handle provided.
4. Push the new power supply module into the power bay until you hear a click.
5. Plug the AC power cord back into the module and power up the nodes.

Figure 6-20. Changing the Power Supply

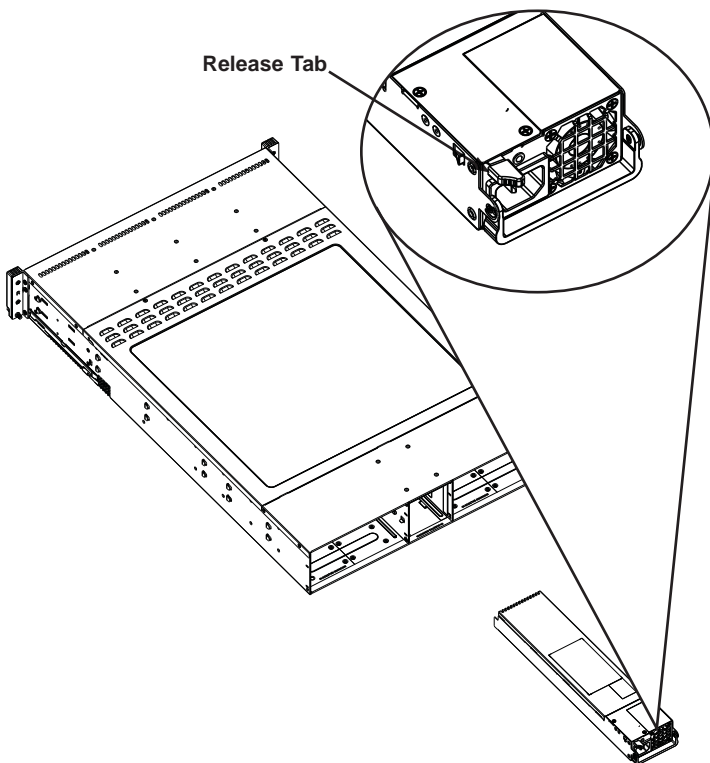

Chapter 7

BIOS

7-1 Introduction

This chapter describes the AMI BIOS Setup Utility for the H8DGT-HF/HIBQF-F. The AMI ROM BIOS is stored in a Flash EEPROM and can be easily updated. This chapter describes the basic navigation of the AMI BIOS Setup Utility setup screens.

Starting BIOS Setup Utility

To enter the AMI BIOS Setup Utility screens, press the <Delete> key while the system is booting up.

Note: In most cases, the <Delete> key is used to invoke the AMI BIOS setup screen. There are a few cases when other keys are used, such as <F1>, <F2>, etc.

Each main BIOS menu option is described in this manual. The Main BIOS setup menu screen has two main frames. The left frame displays all the options that can be configured. Grayed-out options cannot be configured. Options in blue can be configured by the user. The right frame displays the key legend. Above the key legend is an area reserved for a text message. When an option is selected in the left frame, it is highlighted in white. Often a text message will accompany it. (Note: the AMI BIOS has default text messages built in. Supermicro retains the option to include, omit, or change any of these text messages.)

The AMI BIOS Setup Utility uses a key-based navigation system called "hot keys". Most of the AMI BIOS setup utility "hot keys" can be used at any time during the setup navigation process. These keys include <F1>, <F10>, <Enter>, <ESC>, arrow keys, etc.

Note: Options printed in **Bold** are default settings.

How To Change the Configuration Data

The configuration data that determines the system parameters may be changed by entering the AMI BIOS Setup utility. This Setup utility can be accessed by pressing at the appropriate time during system boot.

Starting the Setup Utility

Normally, the only visible Power-On Self-Test (POST) routine is the memory test. As the memory is being tested, press the <Delete> key to enter the main menu of the AMI BIOS Setup Utility. From the main menu, you can access the other setup screens. An AMI BIOS identification string is displayed at the left bottom corner of the screen below the copyright message.



Warning! Do not upgrade the BIOS unless your system has a BIOS-related issue. Flashing the wrong BIOS can cause irreparable damage to the system. In no event shall Supermicro be liable for direct, indirect, special, incidental, or consequential damages arising from a BIOS update. If you have to update the BIOS, do not shut down or reset the system while the BIOS is updating. This is to avoid possible boot failure.

7-2 Main Setup

When you first enter the AMI BIOS Setup Utility, you will enter the Main setup screen. You can always return to the Main setup screen by selecting the Main tab on the top of the screen. The Main BIOS Setup screen is shown below.

System Overview: The following BIOS information will be displayed:

System Time/System Date

Use this option to change the system time and date. Highlight System Time or System Date using the arrow keys. Enter new values through the keyboard and press <Enter>. Press the <Tab> key to move between fields. The date must be entered in Day MM/DD/YY format. The time is entered in HH:MM:SS format. (Note: The time is in the 24-hour format. For example, 5:30 P.M. appears as 17:30:00.)

Supermicro H8DGT-HF (or H8DGT-HIBQF)

BIOS Build Version: This item displays the BIOS revision used in your system.

BIOS Build Date: This item displays the date when this BIOS was completed.

AMI BIOS Core Version: This item displays the revision number of the AMI BIOS Core upon which your BIOS was built.

Processor

The AMI BIOS will automatically display the status of the processor used in your system:

- **CPU Type:** This item displays the type of CPU used in the motherboard.
- **Speed:** This item displays the speed of the CPU detected by the BIOS.

- **Physical Count:** This item displays the number of processors installed in your system as detected by the BIOS.
- **Logical Count:** This item displays the number of CPU Cores installed in your system as detected by the BIOS.
- **Micro_code Revision:** This item displays the revision number of the BIOS Micro_code used in your system.

System Memory

This displays the size of memory available in the system:

- **Size:** This item displays the memory size detected by the BIOS.

Use this option to change the system time and date. Highlight System Time or System Date using the arrow keys. Enter new values through the keyboard. Press the <Tab> key or the arrow keys to move between fields. The date must be entered in Day MM/DD/YY format. The time is entered in HH:MM:SS format. (Note: The time is in the 24-hour format. For example, 5:30 P.M. appears as 17:30:00.)

AMIBIOS

Version

Build Date

Processor

The AMI BIOS will automatically display the status of processor as shown below:

Type of Processor

Speed

Physical Count

Logical Count

System Memory

This displays the size of memory available in the system:

Populated Size

Available Size

7-3 Advanced Setup Configurations

► Boot Feature Configuration

Quick Boot

If Enabled, this option will skip certain tests during POST to reduce the time needed for the system to boot up. The options are **Enabled** and Disabled.

Quiet Boot

If Disabled, normal POST messages will be displayed on boot-up. If **Enabled**, this display the OEM logo instead of POST messages.

Add On ROM Display Mode

This option sets the display mode for Option ROM. The options are **Force BIOS** or Keep Current.

Bootup Num Lock

This option selects the power-on state for the NUM lock to either **On** or Off.

Wait for F1 if Error

This setting controls the system response when an error is detected during the boot sequence. When enabled, BIOS will stop the boot sequence when an error is detected, at which point you will need to press the F1 button to re-enter the BIOS setup menu. The options are **Enabled** and Disabled.

Hit 'DEL' Message Display

Use this option to **Enable** or Disable the "Press DEL to run setup" message in POST.

Watch Dog Function

This option allows the system to restart when it isn't active for more than 5-minutes. Options include Enabled and **Disabled**.

Power Button Function

Use this option to select the mode for the power button when it is turned off. Options include 4 Seconds Override or **Instant Off**.

Restore on AC Power Loss

This option sets the action the system will take if there is an AC power loss to the system. Options include Power Off, Power On or **Last State**.

Interrupt 19 Capture

Select Enabled to allow ROMs to trap Interrupt 19. The options are **Enabled** and Disabled.

► Processor & Clock Options Configuration

CPU Configuration

This displays static information on the Module Version, AGESA Version, Physical Count and Logical Count for the system's processor(s) and clock.

CPU Information

This setting is used to select which physical CPU's information to display. Options include **Processor 0** or Processor 1. The information for the selected processor includes Processor number, Revision, Cache L1/L2/L3, Speed, NB CLK, Able to Change Frequency and uCode Patch Level.

Note: Zero is always the "Boot Strap Processor" or main CPU with all others being "Application Processors".

GART Error Reporting

This option should remain disabled for normal operation. The driver developer may enable this option for testing purposes. Options are Enabled or **Disabled**.

Microcode Update

This setting **Enables** or Disables microcode updating.

Secure Virtual Machine Mode

This setting is used to **Enable** or Disable SVM.

Power Now

This setting is used to **Enable** or Disable the AMD Power Now feature.

Power Cap

This option can decide the highest P-state in the OS. Options include **P-state 0** through P-state 4.

ACPI SRAT Table

This option **Enables** or Disables the building of the ACPI SRAT Table.

CPU Down Core

This option sets down core support for the CPU. Options include **Disabled**, 2 Cores through 10 Cores in even numbered increments.

C1E Support

This option **Enables** or Disables C1E support.

Clock Speed Spectrum

This option enables or **disables** spread spectrum modulation.

▶ **Advanced Chipset Control Configuration**

▶ **NorthBridge Configuration**

▶ **Memory Configuration**

Bank Interleaving

Select Auto to automatically enable a bank-interleaving memory scheme when this function is supported by the processor. The options are **Auto** and Disabled.

Node Interleaving

This option enables node memory interleaving. Options include Auto or **Disabled**.

Channel Interleaving

This option enables channel memory interleaving. Options include **Auto** or Disabled.

CS Sparing

This setting will reserve a spare memory rank in each node when enabled. Options are Enabled and **Disabled**.

Bank Swizzle Mode

This setting **Enables** or Disables the bank swizzle mode.

▶ **ECC Configuration**

ECC Mode

This submenu sets the level of ECC protection. Options include Disabled, **Basic**, Good, Super, Max and User. Selecting User activates the other options for user setting.

Note: The "Super" ECC mode dynamically sets the DRAM scrub rate so all of memory is scrubbed in 8-hours.

DRAM ECC Enable

This setting allows hardware to report and correct memory errors automatically, maintaining system integrity. Options are **Enabled** or Disabled.

► DRAM Timing Configuration

DRAM Timing Config

This setting specifies the DRAM timing configuration. Options are **Auto** and Manual.

Memory Timing Parameters

This selects the which node's timing parameters to display. Options include **CPU Node 0**, CPU Node 1, CPU Node 2 or CPU Node 3.

IOMMU

This setting is used to enable or disable or set the GART size in systems without AGP. Options include Enabled and **Disabled**.

OHCI/EHCI HC Device Functions

These settings allow you to either **Enable** or Disable functions for OHCI or EHCI bus devices.

USB 2.0 Controller Mode

Use this setting to configure the USB 2.0 Controller in either Hi-Speed (480 Mps) or Full Speed (12 Mps) mode. Options include **Enabled** (Hi-Speed Mode) or Disabled (Full Speed Mode).

Legacy USB Support

Select "Enabled" to enable the support for USB Legacy. Disable Legacy support if there are no USB devices installed in the system. "Auto" disabled Legacy support if no USB devices are connected. The options are Disabled, Enabled and **Auto**.

► IDE Configuration

On Chip SATA Channel

This setting allows you to **Enable** or Disable the OnChip SATA channel.

On Chip SATA Type

Use this setting to set the On Chip SATA type. Options include Native IDE, RAID, **AMD_AHCI** and Legacy IDE.

SATA IDE Combined Mode

This setting allows you to **Enable** or Disable the SATA IDE combined mode.

PATA Channel Configuration

This allows you to set PATA channel configuration. Options include **SATA as Primary** or SATA as secondary.

► Primary/Secondary/Third/Fourth IDE Master/Slave

LBA/Large Mode

LBA (Logical Block Addressing) is a method of addressing data on a disk drive. The options are Disabled and **Auto**.

Block (Multi-Sector Transfer)

Block mode boosts IDE drive performance by increasing the amount of data transferred. Only 512 bytes of data can be transferred per interrupt if block mode is not used. Block mode allows transfers of up to 64 KB per interrupt.

Select "Disabled" to allow the data to be transferred from and to the device one sector at a time. Select "Auto" to allows the data transfer from and to the device occur multiple sectors at a time if the device supports it. The options are **Auto** and Disabled.

PIO Mode

PIO (Programmable I/O) mode programs timing cycles between the IDE drive and the programmable IDE controller. As the PIO mode increases, the cycle time decreases.

The options are **Auto**, 0, 1, 2, 3, and 4. Select Auto to allow BIOS to auto detect the PIO mode. Use this value if the IDE disk drive support cannot be determined. Select 0 to allow BIOS to use PIO mode 0, which has a data transfer rate of 3.3 MBs. Select 1 to allow BIOS to use PIO mode 1, which has a data transfer rate of 5.2 MBs. Select 2 to allow BIOS to use PIO mode 2, which has a data transfer rate of 8.3 MBs. Select 3 to allow BIOS to use PIO mode 3, which has a data transfer rate of 11.1 MBs. Select 4 to allow BIOS to use PIO mode 4, which has a data transfer rate of 16.6 MBs. This setting generally works with all hard disk drives manufactured after 1999. For other disk drives, such as IDE CD-ROM drives, check the specifications of the drive.

DMA Mode

Selects the DMA Mode. Options are **Auto**, SWDMA0, SWDMA1, SWDMA2, MWDMA0, MDWDMA1, MWDMA2, UDMA0, UDMA1, UDMA2, UDMA3, UDMA4 and UDMA5. (SWDMA=Single Word DMA, MWDMA=Multi Word DMA, UDMA=UltraDMA.)

S.M.A.R.T.

Self-Monitoring Analysis and Reporting Technology (SMART) can help predict impending drive failures. Select "Auto" to allow BIOS to auto detect hard disk drive support. Select "Disabled" to prevent AMI BIOS from using the S.M.A.R.T. Select "Enabled" to allow AMI BIOS to use the S.M.A.R.T. to support hard drive disk. The options are Disabled, Enabled, and **Auto**.

32-Bit Data Transfer

Select "Enabled" to activate the function of 32-Bit data transfer. Select "Disabled" to deactivate the function. The options are **Enabled** and Disabled.

IDE Detect Timeout (Sec)

Use the +/- keys to adjust and select the time out for detecting ATA/ATAPI devices. The default value is **35**.

► PCI/PnP Configuration

Clear NVRAM

Select Yes to clear NVRAM during boot-up. The options are Yes and **No**.

Plug & Play O/S

Select Yes to allow the OS to configure Plug & Play devices. (This is not required for system boot if your system has an OS that supports Plug & Play.) Select **No** to allow AMIBIOS to configure all devices in the system.

PCI Latency Timer

This option sets the latency of all PCI devices on the PCI bus. Select a value to set the PCI latency in PCI clock cycles. Options are 32, **64**, 96, 128, 160, 192, 224 and 248.

PCI IDE Busmaster

Use this setting to **Enable** or Disable BIOS enabled uses of PCI Busmastering for reading or writing to IDE drives.

Onboard InfiniBand Controller

This option **Enables** or Disables the onboard InfiniBand controller.

Onboard VGA Controller

This option **Enables** or Disables the onboard VGA controller.

Onboard LAN Controller

This option **Enables** or Disables the onboard LAN controller.

ROM Scan Ordering

This setting determines which kind of option ROM activates prior to another. Options include **Onboard First** and Addon First.

PCIe X16 Slot 1

These settings **Enable** or Disable the specified PCIe slot in your system.

Onboard LAN Option ROM Select

This setting allows you to select the onboard LAN option ROM for iSCSI or **PXE**.

Note: You must enable **ONLY** LAN1 when the iSCSI support option is specified.

Load Onboard LAN 1 Option ROM

This option allows you to **enable** or disable the onboard LAN 1 option ROM.

Load Onboard LAN 2 Option ROM

This option allows you to **enable** or disable the onboard LAN 2 option ROM.

Primary Video Controller

This option specifies the primary video controller for **Onboard VGA** or Other.

► SuperIO Device Configuration**Serial 1 Address**

This option specifies the base I/O port address and Interrupt Request address of serial port 1. Select "Disabled" to prevent the serial port from accessing any system resources. When this option is set to *Disabled*, the serial port physically becomes unavailable. Select "3F8/IRQ4" to allow the serial port to use 3F8 as its I/O port address and IRQ 4 for the interrupt address. Options include Disabled, **3F8/IRQ4**, 3E8/IRQ4 and 2E8/IRQ3

Serial 2 Address

This option specifies the base I/O port address and Interrupt Request address of serial port 2. Select "Disabled" to prevent the serial port from accessing any system resources. When this option is set to "Disabled", the serial port physically becomes unavailable. Select "2F8/IRQ3" to allow the serial port to use 2F8 as its I/O port address and IRQ 3 for the interrupt address. Options include Disabled, **2F8/IRQ3**, 3E8/IRQ4 and 2F8/IRQ3.

Serial Port 2 Attribute

This option allows you to set COM2 as a normal serial port or as virtual COM for SOL. Options are **SOL** or COM.

► Remote Access Configuration

Remote Access

Use this option to **Enable** or Disable Remote Access in your system. If enabled, the settings below will appear.

Serial Port Number

Use this setting to select the serial port for console redirection. Options include COM1, **COM2***. The displayed base address and IRQ for the serial port changes to reflect the selection you make.

Note: Make sure the selected port is enabled.

Serial Port Mode

Selects the serial port settings to use. Options are **(115200 8, n, 1)**, (57600 8, n, 1), (38400 8, n, 1), (19200 8, n, 1) and (09600 8, n, 1).

Flow Control

Selects the flow control to be used for console redirection. Options are **None**, Hardware and Software.

Redirection After BIOS POST

Options are Disable (no redirection after BIOS POST), Boot Loader (redirection during POST and during boot loader) and **Always** (redirection always active). Note that some OS's may not work with this set to Always.

Terminal Type

Selects the type of the target terminal. Options are **ANSI**, VT100 and VT-UTF8.

VT-UTF8 Combo Key Support

Allows you to **Enable** or Disable VT-UTF8 combination key support for ANSI/VT100 terminals.

Sredir Memory Display Delay

Use this setting to set the delay in seconds to display memory information. Options are **No Delay**, 1 sec, 2 secs and 4 secs.

► Hardware Health Configuration

CPU Overheat Alarm

This setting allows you to specify the type of alarm for CPU overheating. Options include The Early Alarm and **The Default Alarm**.

Fan Speed Control Modes

This feature allows the user to determine how the system will control the speed of the onboard fans. The options are Full Speed/FS (Max Cooling), Performance/PF (Better Cooling), **Balanced/BL** (Balance between performance and energy saving), Energy Saving/ES (Lower Power and Noise).

Other items in the submenu are systems monitor displays for the following information:

CPU 1 Temperature, CPU 2 Temperature, NB Temperature, VRD1 Temperature, VRD2 Temperature, System Temperature, Air Temperature, Fan 1 Reading, Fan 2 Reading, CPU1 Vcore, CPU2 Vcore, CPU1 Mem VTT, CPU2 Mem VTT, CPU1 Mem, CPU2 Mem, 1.1V, 1.8V, 5V +12V, 3.3 Vcc, 3.3 VSB, VBAT and HT Voltage.

► ACPI Configuration

ACPI Aware O/S

This setting Enables or Disables ACPI support for the system's operating system. Options include **Yes** (enabled) or No (disabled).

ACPI APIC Support

Determines whether to include the ACPI APIC table pointer in the RSDT pointer list. The available options are **Enabled** and Disabled.

Headless Mode

Use this setting to Enable or **Disable** headless operation mode through ACPI.

ACPI Version Features

Use this setting to determine which ACPI version to use. Options are ACPI v1.0, **ACPI v2.0** and ACPI v3.0.

▶ IPMI Configuration

This menu shows static information about the IPMI firmware revision and status of the BMC, as well as options for IPMI configuration.

▶ View BMC System Event Log

Pressing the Enter key will open the following settings. Use the "+" and "-" keys to navigate through the system event log.

Clear BMC System Event Log

Selecting this and pressing the Enter key will clear the BMC system event log.

▶ Set LAN Configuration

Use the "+" and "-" keys to choose the desired channel number. This displays Channel Number and Channel Number Status information.

This menu contains options for inputting settings for the SET LAN Configuration Command. See IPMI 1.5 Specification, table 11.1 for details. Use the "+" and "-" keys to choose the desired channel number.

Note: Each question in this group may take a considerable amount of time.

IP Address Source

Select the source of this machine's IP address. If Static is selected, you will need to know and enter manually the IP address of this machine below. If DHCP is selected, the BIOS will search for a DHCP (Dynamic Host Configuration Protocol) server in the network it is attached to, and request the next available IP address. The options are **DHCP** and Static.

The following items are assigned IP addresses automatically if DHCP is selected under IP Address Source above:

IP Address

This submenu sets the IP address source as either Static or DHCP. Selecting Static allows you to manually set the IP Address, Subnet Mask and Gateway Address.

In the field provided here enter the IP address in the decimal form of xxx.xxx.xxx.xxx with xxx having a value of less than 256 and in decimal form only. The IP address and current IP address in the BMC are shown.

Subnet Mask

In the field provided here enter the Subnet address in the decimal form of xxx.xxx.xxx.xxx with xxx having a value of less than 256 and in decimal form only. The current subnet address in the BMC is shown.

Gateway Address

In the field provided here enter the Gateway address in the decimal form of xxx.xxx.xxx.xxx with xxx having a value of less than 256 and in decimal form only. The current Gateway address in the BMC is shown.

MAC Address

In the field provided here enter the MAC address in the hex form of xx.xx.xx.xx.xx.xx with xx in hex form only. The current MAC address in the BMC is shown.

BMC Watch Dog Timer Action

This setting is used to set the Watch Dog function, which allows the BMC to reset or powerdown the system if the OS crashes or hangs. Options include **Disabled**, Reset System, Power Down and Power Cycle.

► Event Log Configuration**View Event Log**

Pressing the Enter key will open the event log. Use the "↑" and "↓" keys to navigate through the system event log.

Mark All Events as Read

Selecting this and pressing the Enter key marks all events as read in the event log.

Clear Event Log

Selecting this and pressing the Enter key clears the system event log.

SR56x0 (RD890S) PCIE Error Log

This setting allows you set an error log ofr PCIE errors. Options include Yes or **No**.

4-3 Security Menu

AMI BIOS provides a Supervisor and a User password. If you use both passwords, the Supervisor password must be set first.

Change Supervisor Password

Select this option and press <Enter> to access the sub menu, and then type in the password.

Change User Password

Select this option and press <Enter> to access the sub menu, and then type in the password.

Boot Sector Virus Protection

This option is near the bottom of the Security Setup screen. Select "Disabled" to deactivate the Boot Sector Virus Protection. Select "Enabled" to enable boot sector protection. When "Enabled", AMI BIOS displays a warning when any program (or virus) issues a Disk Format command or attempts to write to the boot sector of the hard disk drive. The options are Enabled and **Disabled**.

4-4 Boot Menu

The Boot Menu is accessible only when the "Load Onboard LAN Option ROM" setting (in the PCI/PnP Configuration menu) is enabled.

► Boot Device Priority

This feature allows you to prioritize the boot sequence from the list of available devices. A device that is in parenthesis has been disabled in the corresponding type menu.

► Hard Disk Drives

This feature allows you to specify the boot sequence from the list of available hard disk drives. A device that is in parenthesis has been disabled in the corresponding type menu.

Retry Boot Devices

This option allows you to retry boot devices. Options include Enabled and **Disabled**.

4-5 Exit Menu

Select the Exit tab from AMI BIOS Setup Utility screen to enter the Exit BIOS Setup screen.

Save Changes and Exit

When you have completed the system configuration changes, select this option to leave BIOS Setup and reboot the computer, so the new system configuration parameters can take effect. Select Save Changes and Exit from the Exit menu and press <Enter>.

Discard Changes and Exit

Select this option to quit BIOS Setup without making any permanent changes to the system configuration and reboot the computer. Select Discard Changes and Exit from the Exit menu and press <Enter>.

Discard Changes

Select this option and press <Enter> to discard all the changes and return to AMI BIOS Utility Program.

Load Optimal Defaults

To set this feature, select Load Optimal Defaults from the Exit menu and press <Enter>. Then Select "OK" to allow BIOS to automatically load the Optimal Defaults as the BIOS Settings. The Optimal settings are designed for maximum system performance, but may not work best for all computer applications.

Load Fail-Safe Defaults

To set this feature, select Load Fail-Safe Defaults from the Exit menu and press <Enter>. The Fail-Safe settings are designed for maximum system stability, but not maximum performance.

Notes

Appendix A

BIOS Error Beep Codes

During the POST (Power-On Self-Test) routines, which are performed each time the system is powered on, errors may occur.

Non-fatal errors are those which, in most cases, allow the system to continue the boot-up process. The error messages normally appear on the screen.

Fatal errors are those which will not allow the system to continue the boot-up procedure. If a fatal error occurs, you should consult with your system manufacturer for possible repairs.

These fatal errors are usually communicated through a series of audible beeps. The numbers on the fatal error list (on the following page) correspond to the number of beeps for the corresponding error. All errors listed, with the exception of Beep Code 8, are fatal errors.

A-1 AMIBIOS Error Beep Codes

Beep Code	Error Message	Description
1 beep	Refresh	Circuits have been reset (Ready to power up)
5 short, 1 long	Memory error	No memory detected in system
1 long, 8 short	Video error	Video adapter disabled or missing

Notes

Appendix B

Installing Windows

After all hardware components have been installed, you must first configure Intel South Bridge RAID Settings before you install the Windows OS and other software drivers. To configure RAID settings, please refer to RAID Configuration User Guides posted on our web site at www.supermicro.com/support/manuals.

B-1 Installing the Windows OS for a RAID System

1. Insert Microsoft's Windows XP/2003/2008/Vista Setup CD in the CD driver and the system will start booting up from CD.
2. Press the <F6> key when the message "Press F6 if you need to install a third party RAID driver" displays.
3. When the Windows OS Setup screen appears, press "S" to specify additional device(s).
4. Insert the driver diskette "ITE RAID Windows XP/2003/2008/Vista Driver for IDE" into the floppy drive and press the <Enter> key.
5. When the Windows OS Setup screen appears, press "S" to specify additional device(s).
6. Insert the driver diskette into the drive and press the <Enter> key.
7. Choose the LSI SAS RAID driver indicated in the Windows OS Setup screen, and press the <Enter> key.
8. Press the <Enter> key to continue the installation process. (If you need to specify any additional devices to be installed, do so at this time.) Once all devices are specified, press the <Enter> key to continue with the installation.
9. From the Windows OS Setup screen, press the <Enter> key. The Windows OS Setup will automatically load all device files and then, continue the Windows OS installation.
10. After the Windows OS Installation is completed, the system will automatically reboot.

B-2 Installing the Windows OS for a Non-RAID System

1. Insert Microsoft's Windows OS Setup CD in the CD-ROM drive and the system will start booting up from the CD.
2. Continue with the installation. The Windows OS Setup screen will display.
3. From the Windows OS Setup screen, press the <Enter> key. The OS Setup will automatically load all device files and then continue with the Windows installation.
4. After the installation has completed, the system will automatically reboot.
5. Insert the Supermicro Setup CD that came with your system into the CD-ROM drive during system boot and the main screen will display.

Appendix C

System Specifications

Note: Unless noted specifications apply to a complete system (all serverboards).

Processors

Dual AMD Opteron 6100 series processors (Socket G34 type)

Note: Both CPUs must be of the same type.

Note: Please refer to our web site for a complete listing of supported processors.

Chipset

AMD SR5670/SP5100 Chipset

BIOS

16 Mb AMIBIOS® SPI Flash ROM (each serverboard)

Memory Capacity

Sixteen (16) single/dual/tri/quad channel DIMM slots supporting up to 256 GB of DDR3-1333/1066/800 registered ECC or 64GB of DDR3 Unbuffered ECC/non-ECC SDRAM

Note: Interleaved memory - requires memory must be installed four modules at a time. See Section 5-6 for details.

SATA Controller

On-chip (SP5100) SATA controller supporting three (3) SATA HDD (RAID 0 and 1 supported) (each serverboard)

Drive Bays

Twelve hot-swap drive bays to house twelve SATA drives (3 for each node)

Expansion Slots

Total of four PCI-Express x16 low-profile slots on serverboards (one for each serverboard)

Serverboard

Four H8DGT-HF/HIBQF (Extended ATX form factor)

Dimensions: 6.78" x 16.64" (172 x 423 mm)

Chassis

SC827H-R1400BP (2U rackmount)

Dimensions: (WxHxD) 17.25 x 3.47 x 28.5 in. (438 x 88 x 724 mm)

Weight

Gross (Bare Bone): 85 lbs. (38.6 kg.)

System Cooling

Four 8-cm PWM system cooling fans

System Input Requirements

AC Input Voltage: 100-240V AC auto-range

Rated Input Current: 13A - 4A

Rated Input Frequency: 50 to 60 Hz

Efficiency: 80+ (Gold Level)

Power Supply

Rated Output Power: 1400W (Part# PWS-1K41P-1R)

Rated Output Voltages: +12V (116A@180-240V, 92A@100-140V), +5Vsb (4A)

Operating Environment

Operating Temperature: 0° to 35° C (50° to 95° F)

Non-operating Temperature: -40° to 70° C (-40° to 158° F)

Operating Relative Humidity: 20% to 95% (non-condensing)

Non-operating Relative Humidity: 5 to 95% (non-condensing)

Regulatory Compliance

Electromagnetic Emissions: FCC Class A, EN 55022 Class A, EN 61000-3-2/-3-3, CISPR 22 Class A

Electromagnetic Immunity: EN 55024/CISPR 24, (EN 61000-4-2, EN 61000-4-3, EN 61000-4-4, EN 61000-4-5, EN 61000-4-6, EN 61000-4-8, EN 61000-4-11)

Safety: CSA/EN/IEC/UL 60950-1 Compliant, UL or CSA Listed (USA and Canada), CE Marking (Europe)

California Best Management Practices Regulations for Perchlorate Materials: This Perchlorate warning applies only to products containing CR (Manganese Dioxide) Lithium coin cells. "Perchlorate Material-special handling may apply. See www.dtsc.ca.gov/hazardouswaste/perchlorate" for further details.

(continued from front)

The products sold by Supermicro are not intended for and will not be used in life support systems, medical equipment, nuclear facilities or systems, aircraft, aircraft devices, aircraft/emergency communication devices or other critical systems whose failure to perform be reasonably expected to result in significant injury or loss of life or catastrophic property damage. Accordingly, Supermicro disclaims any and all liability, and should buyer use or sell such products for use in such ultra-hazardous applications, it does so entirely at its own risk. Furthermore, buyer agrees to fully indemnify, defend and hold Supermicro harmless for and against any and all claims, demands, actions, litigation, and proceedings of any kind arising out of or related to such ultra-hazardous use or sale.