

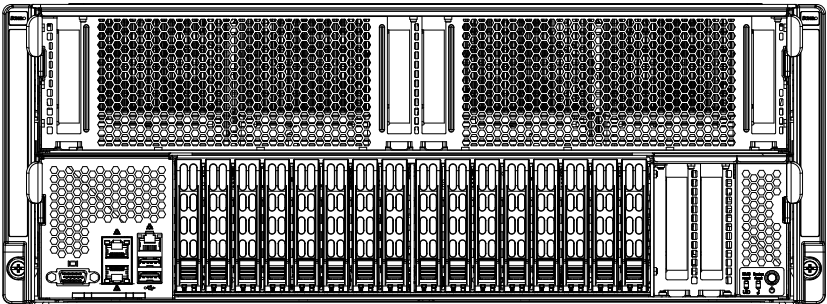

SUPERSERVER®

4028GR-TXR
4028GR-TXRT



USER'S MANUAL

Revision 1.0

The information in this User's Manual has been carefully reviewed and is believed to be accurate. The vendor assumes no responsibility for any inaccuracies that may be contained in this document, makes no commitment to update or to keep current the information in this manual, or to notify any person or organization of the updates. **Please Note: For the most up-to-date version of this manual, please see our web site at www.supermicro.com.**

Super Micro Computer, Inc. ("Supermicro") reserves the right to make changes to the product described in this manual at any time and without notice. This product, including software and documentation, is the property of Supermicro and/or its licensors, and is supplied only under a license. Any use or reproduction of this product is not allowed, except as expressly permitted by the terms of said license.

IN NO EVENT WILL SUPERMICRO BE LIABLE FOR DIRECT, INDIRECT, SPECIAL, INCIDENTAL, SPECULATIVE OR CONSEQUENTIAL DAMAGES ARISING FROM THE USE OR INABILITY TO USE THIS PRODUCT OR DOCUMENTATION, EVEN IF ADVISED OF THE POSSIBILITY OF SUCH DAMAGES. IN PARTICULAR, SUPERMICRO SHALL NOT HAVE LIABILITY FOR ANY HARDWARE, SOFTWARE, OR DATA STORED OR USED WITH THE PRODUCT, INCLUDING THE COSTS OF REPAIRING, REPLACING, INTEGRATING, INSTALLING OR RECOVERING SUCH HARDWARE, SOFTWARE, OR DATA.

Any disputes arising between manufacturer and customer shall be governed by the laws of Santa Clara County in the State of California, USA. The State of California, County of Santa Clara shall be the exclusive venue for the resolution of any such disputes. Super Micro's total liability for all claims will not exceed the price paid for the hardware product.

FCC Statement: This equipment has been tested and found to comply with the limits for a Class A digital device pursuant to Part 15 of the FCC Rules. These limits are designed to provide reasonable protection against harmful interference when the equipment is operated in a commercial environment. This equipment generates, uses, and can radiate radio frequency energy and, if not installed and used in accordance with the manufacturer's instruction manual, may cause harmful interference with radio communications. Operation of this equipment in a residential area is likely to cause harmful interference, in which case you will be required to correct the interference at your own expense.

California Best Management Practices Regulations for Perchlorate Materials: This Perchlorate warning applies only to products containing CR (Manganese Dioxide) Lithium coin cells. "Perchlorate Material-special handling may apply. See www.dtsc.ca.gov/hazardouswaste/perchlorate"

WARNING: Handling of lead solder materials used in this product may expose you to lead, a chemical known to the State of California to cause birth defects and other reproductive harm.

Manual Revision 1.0

Release Date: April 20, 2017

Unless you request and receive written permission from Super Micro Computer, Inc., you may not copy any part of this document.

Information in this document is subject to change without notice. Other products and companies referred to herein are trademarks or registered trademarks of their respective companies or mark holders.

Copyright © 2017 by Super Micro Computer, Inc.
All rights reserved.

Printed in the United States of America

Preface

About this Manual

This manual is written for professional system integrators and PC technicians. It provides information for the installation and use of the SuperServer 4028GR-TXR(T). Installation and maintenance should be performed by experienced technicians only.

Please refer to the server specifications page on our Web site for updates on supported memory, processors and operating systems (<http://www.supermicro.com>).

Notes

For your system to work properly, please follow the links below to download all necessary drivers/utilities and the user's manual for your server.

- Supermicro product manuals: <http://www.supermicro.com/support/manuals/>
- Product drivers and utilities: <ftp://ftp.supermicro.com>
- Product safety info:
http://www.supermicro.com/about/policies/safety_information.cfm

If you have any questions, please contact our support team at:
support@supermicro.com

This manual may be periodically updated without notice. Please check the Supermicro Web site for possible updates to the manual revision level.

Warnings

Special attention should be given to the following symbols used in this manual.



Warning! Indicates important information given to prevent equipment/property damage or personal injury.



Warning! Indicates high voltage may be encountered when performing a procedure.

Contents

Chapter 1 Introduction

| | | |
|-----|------------------------------|-----|
| 1-1 | Overview | 1-1 |
| 1-2 | Motherboard Features..... | 1-2 |
| | Processors | 1-2 |
| | Memory | 1-2 |
| | Serial ATA..... | 1-2 |
| | PCI Expansion Slots | 1-2 |
| | Input/Output Ports | 1-2 |
| | IPMI | 1-2 |
| 1-3 | Chassis Features | 1-4 |
| | System Power | 1-4 |
| | Storage Drives | 1-4 |
| | Front Control Panel..... | 1-4 |
| | Cooling System | 1-4 |
| | Midplane..... | 1-4 |
| 1-4 | GPUs and Add-on Module | 1-5 |
| 1-5 | Contacting Supermicro..... | 1-6 |

Chapter 2 Rack Installation

| | | |
|-----|--------------------------------------|-----|
| 2-1 | Unpacking the System | 2-1 |
| 2-2 | Preparing for Setup..... | 2-1 |
| | Choosing a Setup Location..... | 2-1 |
| 2-3 | Warnings and Precautions | 2-2 |
| | Rack Precautions | 2-2 |
| | General Server Precautions..... | 2-2 |
| | Rack Mounting Considerations | 2-3 |
| 2-4 | Procedure for Rack Mounting | 2-4 |
| | Overview of the Rack Rails | 2-4 |
| | Adjusting the Rails | 2-4 |
| | Installing the Rails on a Rack | 2-5 |
| | Chassis Installation | 2-6 |

Chapter 3 System Interface

| | | |
|-----|---|-----|
| 3-1 | Overview | 3-1 |
| 3-2 | Control Panel Buttons/Indicators | 3-2 |
| | Power | 3-2 |
| | System Reset Button/Information LED | 3-2 |
| | BMC Reset/UID | 3-2 |

| | | |
|-----|------------------------------------|-----|
| 3-3 | Overheating..... | 3-3 |
| | Overheat Temperature Setting | 3-3 |
| | Responses..... | 3-3 |
| 3-4 | Drive Carrier LEDs..... | 3-3 |
| 3-5 | Power Supply LEDs | 3-4 |

Chapter 4 Standardized Warning Statements for AC Systems

| | | |
|--|--|------|
| | About Standardized Warning Statements..... | 4-1 |
| | Warning Definition | 4-1 |
| | Installation Instructions..... | 4-4 |
| | Circuit Breaker | 4-5 |
| | Power Disconnection Warning | 4-6 |
| | Equipment Installation..... | 4-8 |
| | Restricted Area..... | 4-9 |
| | Battery Handling..... | 4-10 |
| | Redundant Power Supplies (if applicable to your system)..... | 4-12 |
| | Backplane Voltage (if applicable to your system)..... | 4-13 |
| | Comply with Local and National Electrical Codes | 4-14 |
| | Product Disposal | 4-15 |
| | Hot Swap Fan Warning..... | 4-16 |
| | Power Cable and AC Adapter | 4-18 |

Chapter 5 Advanced Motherboard Setup

| | | |
|-----|--|------|
| 5-1 | Handling the Motherboard | 5-1 |
| | Precautions | 5-1 |
| | Unpacking | 5-1 |
| 5-2 | Connecting Cables..... | 5-2 |
| | Data Cables | 5-2 |
| | Power Cables..... | 5-2 |
| 5-3 | Input/Output Ports | 5-3 |
| 5-4 | Installing the Processor and Heatsink | 5-4 |
| | Installing an LGA 2011 Processor..... | 5-4 |
| | Installing a CPU Heatsink | 5-7 |
| | Removing the Heatsink | 5-7 |
| 5-5 | Installing Memory | 5-8 |
| | Processor/DIMM Population Configurations | 5-9 |
| 5-6 | Motherboard Details..... | 5-11 |
| | Add-on Module for GPUs..... | 5-13 |
| 5-7 | Connector Definitions..... | 5-14 |
| | Power Connectors | 5-14 |

| | | |
|------|---------------------------|------|
| | Main Power | 5-14 |
| | Midplane Power | 5-14 |
| | Internal Headers | 5-14 |
| 5-8 | Jumper Settings | 5-17 |
| 5-9 | Onboard Indicators | 5-19 |
| 5-10 | SATA Ports | 5-20 |
| 5-11 | Installing Software | 5-21 |
| | SuperDoctor® 5 | 5-22 |
| 5-12 | Onboard Battery | 5-23 |

Chapter 6 Advanced Chassis Setup

| | | |
|-----|--|------|
| 6-1 | Chassis Views | 6-1 |
| 6-2 | Removing Power from the System | 6-2 |
| 6-3 | Installing Storage Drives | 6-3 |
| | Replacing Drives | 6-4 |
| 6-4 | Removing the Chassis Tray Covers | 6-6 |
| 6-5 | Installing Expansion Cards | 6-7 |
| 6-6 | Graphic Processor Units | 6-9 |
| | GPU Mapping | 6-9 |
| | Installing a GPU | 6-10 |
| 6-7 | Installing the Air Shroud | 6-12 |
| 6-8 | Replacing Fans | 6-13 |
| 6-9 | Power Supply | 6-14 |

Chapter 7 BIOS

| | | |
|-----|--|------|
| 7-1 | Introduction | 7-1 |
| | Starting BIOS Setup Utility | 7-1 |
| | How To Change the Configuration Data | 7-1 |
| | Starting the Setup Utility | 7-2 |
| 7-2 | Main Setup | 7-2 |
| 7-3 | Advanced Setup Configurations | 7-4 |
| 7-4 | Event Logs | 7-31 |
| 7-5 | IPMI | 7-33 |
| 7-6 | Security | 7-36 |
| 7-7 | Boot | 7-37 |
| 7-8 | Save & Exit | 7-39 |

Appendix A BIOS Error Beep Codes

Appendix B System Specifications

Chapter 1

Introduction

1-1 Overview

The SuperServer 4028GR-TXR(T) is a GPU optimized server comprised of two main subsystems: the SCR422BG-R4000 4U server chassis and the X10DGO(-T) motherboard, augmented by a GPU board, X10DGO-SXM. It supports up to eight Tesla P100 SXM2 GPUs with up to 80 GB/s GPU-to-GPU NVLINK. The models and features are:

| Model | Network Ports | Power Supply |
|-------------|---------------|-------------------------|
| 4028GR-TXR | Two 1 Gb | 2200 W, 80Plus Titanium |
| 4028GR-TXRT | Two 10 Gb | 2200 W, 80Plus Titanium |

Other components are:

- 4U midplane (BPN-MB-R422)
- Four power supplies with 9-cm fans (PWS-2K21A-2R)
- Four additional 9-cm rear fans (PWS-DF004-1F)
- One air shroud (MCP-310-41808-0B) over PCI slots
- Two active CPU heatsinks (SNK-P0048AP4)
- Storage Accessories
 - One SAS/SATA/NVMe backplane (BPN-SAS3-213A-N8)
 - Sixteen hot-swap drive carriers (MCP-220-00047-0B)
- One rail set (MCP-290-41803-0N)

Operating systems certified for use with the system are listed on the web site.

Note: For your system to work properly, please follow the links below to download all necessary drivers/utilities and the user's manual for your server.

- Supermicro product manuals: <http://www.supermicro.com/support/manuals/>
- Product drivers and utilities: <ftp://ftp.supermicro.com>
- Product safety info:
 - http://www.supermicro.com/about/policies/safety_information.cfm

If you have any questions, please contact our support team at: support@supermicro.com

1-2 Motherboard Features

At the heart of the server is the X10DGO(-T), a dual processor motherboard based on the Intel C612 chipset. This is used in tandem with the X10DGO-SXM plate for eight Pascal SXM GPUs. Below are the main features. (See Figure 1-1 for a block diagram)

Processors

The X10DGO(-T) supports dual Intel Xeon E5-2600 v3/v4 series processors in LGA 2011 sockets (Socket R3). Each processor supports dual Intel QuickPath Interconnect (QPI) links of up to 9.6 GT/s per QPI.

Memory

The motherboard has twenty-four DIMM slots that can support up to 1.5 TB of Load Reduced (LRDIMM) or Registered (RDIMM) DDR4 ECC, 288-pin, at 2400/2133/1866/1600/1333 MHz. DIMMs up to 64 GB at 1.2V.

Serial ATA

The motherboard supports ten SATA 3.0 ports. That is four I-SATA, two more I-SATA with SuperDOM support, and four S-SATA. RAID 0, 1, 5 and 10 can be enabled.

PCI Expansion Slots

The X10DGO(-T) system motherboard offers two x8 PCIe expansion card slots. The X10DGO-SXM GPU board offers four additional x16 PCIe slots. All expansion cards must be low profile.

Note that both CPUs must be installed to enable use of all PCIe slots.

Input/Output Ports

The front I/O ports include four USB 3.0 ports, two Ethernet LAN ports (1Gb for X10DGO, 10Gb for X10DGO-T) and one dedicated IPMI 2.0 LAN port, and a VGA (monitor) port.

The motherboard also includes two headers for four front access USB 2.0 ports and one USB 2.0 Type A port.

IPMI

Intelligent Platform Management Interface (IPMI) 2.0 is a hardware-level interface specification that provides remote access, monitoring and administration for

Supermicro servers. IPMI enables administrators to view a server hardware status remotely, receive an alarm automatically if a failure occurs, and power cycle a system that is non-responsive.

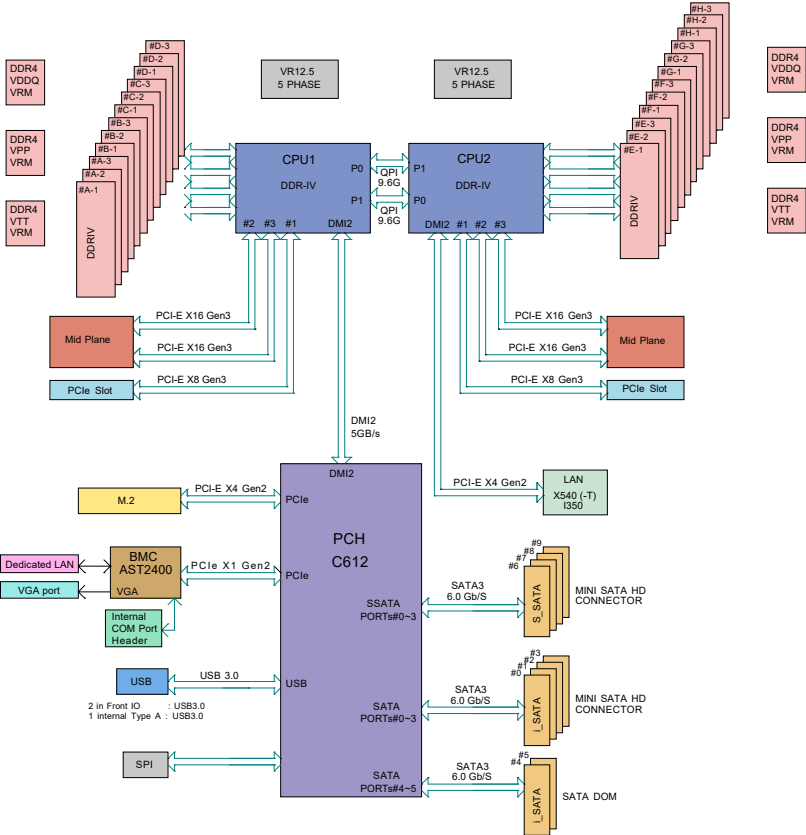

Figure 1-1. Intel C612 Chipset System Block Diagram

Note: This is a general block diagram. See Chapter 5 for details.

1-3 Chassis Features

The 4028GR-TXR(T) server uses the SCR422BG chassis.

System Power

The chassis features a 2+2 redundant power supply system composed of four hot-plug, high efficiency Titanium level 2200 watt power modules. Each power supply is integrated with a system fan.

It also includes four 12 Vdc input redundant fan module power supporting I²C function.

Storage Drives

The chassis includes sixteen hot-swap 2.5" drive bays. Eight hybrid connectors on the backplane support NVMe or SAS/SATA drives, and the rest are SAS or SATA.

Front Control Panel

The control panel provides a system monitoring and control interface. It includes buttons for system power, system reset, and UID. Status LEDs indicate system power, overheat, fan failure, and UID.

Cooling System

The chassis has an innovative cooling design that includes eight 9-cm heavy-duty fans. They offer status monitoring through IPM, dual cooling zones, fan speed control, and Pulse Width Modulation (PWM) control.

In addition, an air shroud helps channel air over the motherboard and PCI slots for maximum cooling. The power supply modules also include a cooling fan. All chassis and power supply fans operate continuously.

Midplane

A Pascal 4U midplane supports the fan and power modules, and connects the GPU add-on board and the motherboard.

1-4 GPUs and Add-on Module

The system supports eight PASCAL SXM2 P100 GPUs installed on the X10DGO-SXM add-on module which is connected to the motherboard by a midplane.

The X10DGO-SXM is connected through Nvidia's Cube Mesh NVLINK architecture. Direct connection between all GPUs are single NVlink (20 GB/s).

A direct connection from the GPUs to the network can be provided from the PCIe PLX switch to the PCIe3.0 x16 up front. Each PCIe PLX switch is root to two SXM2 modules and one PCIe3.0 x16 slot.. A fast network (expansion) card installed on the riser card affords very high speeds. Data can go from GPU to the PLX to the NIC without going through the CPU. For the NIC, the system can support both FDR and EDR (in x16 slots).

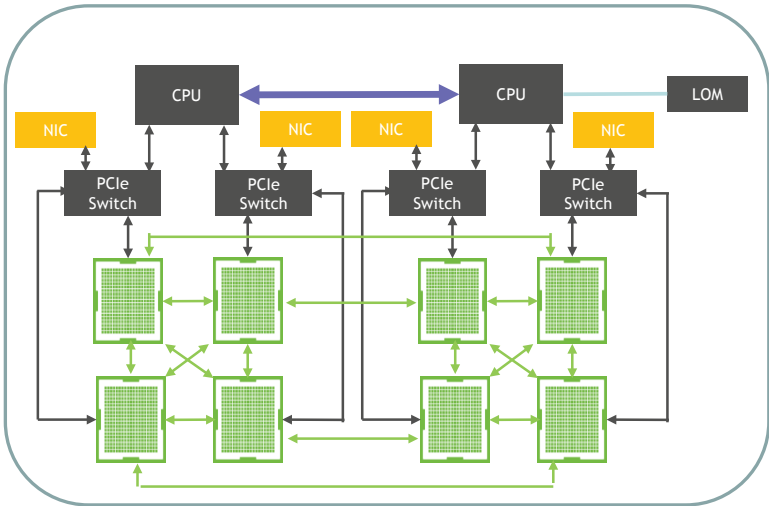

Figure 1-2. NVLink Architecture: Cube Mesh

1-5 Contacting Supermicro

Headquarters

Address: Super Micro Computer, Inc.
980 Rock Ave.
San Jose, CA 95131 U.S.A.

Tel: +1 (408) 503-8000

Fax: +1 (408) 503-8008

Email: marketing@supermicro.com (General Information)
support@supermicro.com (Technical Support)

Web Site: www.supermicro.com

Europe

Address: Super Micro Computer B.V.
Het Sterrenbeeld 28, 5215 ML
's-Hertogenbosch, The Netherlands

Tel: +31 (0) 73-6400390

Fax: +31 (0) 73-6416525

Email: sales@supermicro.nl (General Information)
support@supermicro.nl (Technical Support)
rma@supermicro.nl (Customer Support)

Web Site: www.supermicro.com

Asia-Pacific

Address: Super Micro Computer, Inc.
3F, No. 150, Jian 1st Rd.
Zhonghe Dist., New Taipei City 235
Taiwan (R.O.C)

Tel: +886-(2) 8226-3990

Fax: +886-(2) 8226-3992

Email: support@supermicro.com.tw

Tel: +886-(2)-8226-3990

Web Site: www.supermicro.com.tw

Chapter 2

Rack Installation

This chapter provides instructions for preparing and mounting your chassis in a rack.

2-1 Unpacking the System

You should inspect the box the chassis was shipped in and note if it was damaged in any way. If the chassis itself shows damage, file a damage claim with the carrier who delivered it.

2-2 Preparing for Setup

Decide on a suitable location for the rack unit that will hold your chassis. It should be a clean, dust-free area that is well ventilated. Avoid areas where heat, electrical noise and electromagnetic fields are generated. A nearby grounded power outlet is required.

The box your chassis was shipped in should include two sets of rail assemblies, two rail mounting brackets and the mounting screws to mount the system into the rack. Please read this chapter in its entirety before beginning the installation procedure.

Choosing a Setup Location

- Leave at least 25 inches clearance in front of the rack to open the front door completely.
- Leave approximately 30 inches of clearance in the back of the rack to allow for sufficient airflow and access for servicing.
- It should be a restricted access location, such as a dedicated equipment room or a service closet.

2-3 Warnings and Precautions

Rack Precautions

- Ensure that the leveling jacks on the bottom of the rack are fully extended to the floor with the full weight of the rack resting on them.
- In single rack installations, stabilizers should be attached to the rack.
- In multiple rack installations, the racks should be coupled together.
- Always make sure that the rack is stable before extending a component from the rack.
- Only one chassis should be extended from the rack at a time. Extending two or more chassis simultaneously may cause the rack to become unstable.
- When initially installing the server to a rack, test that the rail locking tabs engage to prevent the server from being overextended. Have a rack lift in place as a precaution in case the test fails.
- In any instance of pulling the system from the rack, always use a rack lift and follow all associated safety precautions.

General Server Precautions

- Review the electrical and general safety precautions that came with the components you are adding to your chassis.
- Determine the placement of each component in the rack before you install the rails.
- Install the heaviest server components on the bottom of the rack first, and then work upward.
- Use a regulating uninterruptible power supply (UPS) to protect the server from power surges, voltage spikes and to keep your system operating in case of a power failure.
- Allow the hot-swappable hard drives and power supply modules to cool before touching them.
- Always keep the rack's front door and all panels and components on the servers closed when not servicing to maintain proper cooling.

Rack Mounting Considerations

Ambient Operating Temperature

If installed in a closed or multi-unit rack assembly, the ambient operating temperature of the rack environment may be greater than the ambient temperature of the room. Therefore, consideration should be given to installing the equipment in an environment compatible with the manufacturer's maximum rated ambient temperature (TMRA).

Sufficient Airflow

Equipment should be mounted into a rack so that the amount of airflow required for safe operation is not compromised.

Circuit Overloading

Consideration should be given to the connection of the equipment to the power supply circuitry and the effect that any possible overloading of circuits might have on overcurrent protection and power supply wiring. Appropriate consideration of equipment nameplate ratings should be used when addressing this concern.

Reliable Ground

A reliable ground must be maintained at all times. To ensure this, the rack itself should be grounded. Particular attention should be given to power supply connections other than the direct connections to the branch circuit (i.e. the use of power strips, etc.).



Warning: To prevent bodily injury when mounting or servicing this unit in a rack, you must take special precautions to ensure that the system remains stable. The following guidelines are provided to ensure your safety:

- This unit should be mounted at the bottom of the rack if it is the only unit in the rack.
- When mounting this unit in a partially filled rack, load the rack from the bottom to the top with the heaviest component at the bottom of the rack.
- If the rack is provided with stabilizing devices, install the stabilizers before mounting or servicing the unit in the rack.
- Slide rail mounted equipment is not to be used as a shelf or a work space.

2-4 Procedure for Rack Mounting

This section provides information on installing the chassis into a rack unit with the rails provided. There are a variety of rack units on the market, so the assembly procedure may differ slightly. Also refer to the installation instructions for your rack unit.

Note: This rail will fit a rack between 28" and 33.5" deep.

Overview of the Rack Rails

The package includes two rail assemblies. Each is specifically designed for the left or right side of the chassis, and so marked. Each rail consists of two sections: a front section which secures to the front post of the rack and a rear section which adjusts in length and secures to the rear post of the rack.

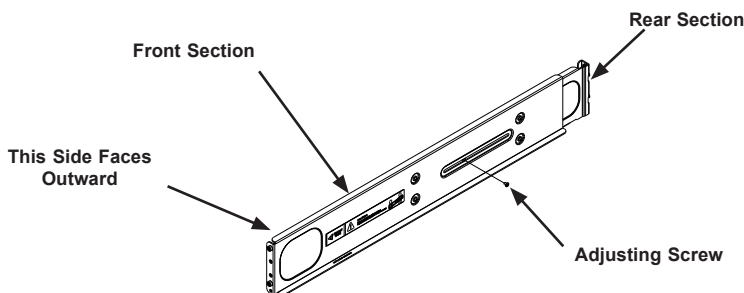

Figure 2-1. Rackmount Rail
(Left Rail assembly shown)

Adjusting the Rails

Each rail assembly has an adjusting screw. Loosen this screw to adjust the length of the rail to fit the depth of your rack.

Installing the Rails on a Rack

Installing the Rails

1. Loosen the adjusting screw to allow the rear section to slide in the front section..
2. Push the small hooks on the front section of the rail into the holes on the front post of the rack and then down, until the spring-loaded pegs snap into the rack holes. Secure the rail to the rack with screws.
3. Pull out the rear section of the outer rail, adjusting the length until it fits within the posts of the rack and align the small hooks with the appropriate holes on the rear post of the rack. Be sure the rail is level.
4. Mount the rear section onto the rack. Secure the rail with screws.

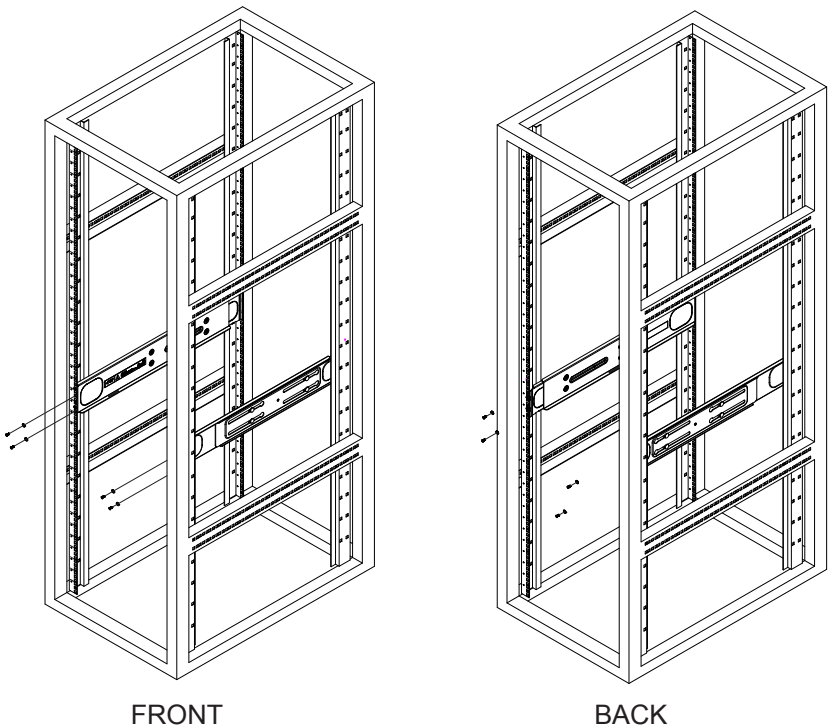

Figure 2-2. Attaching the Rails to a Rack

Note: Figures are for illustrative purposes only. Always install servers into racks from the bottom up.

Chassis Installation

Slide the chassis into the rack so that the bottom of the chassis slide onto the bottom lip of the rail.

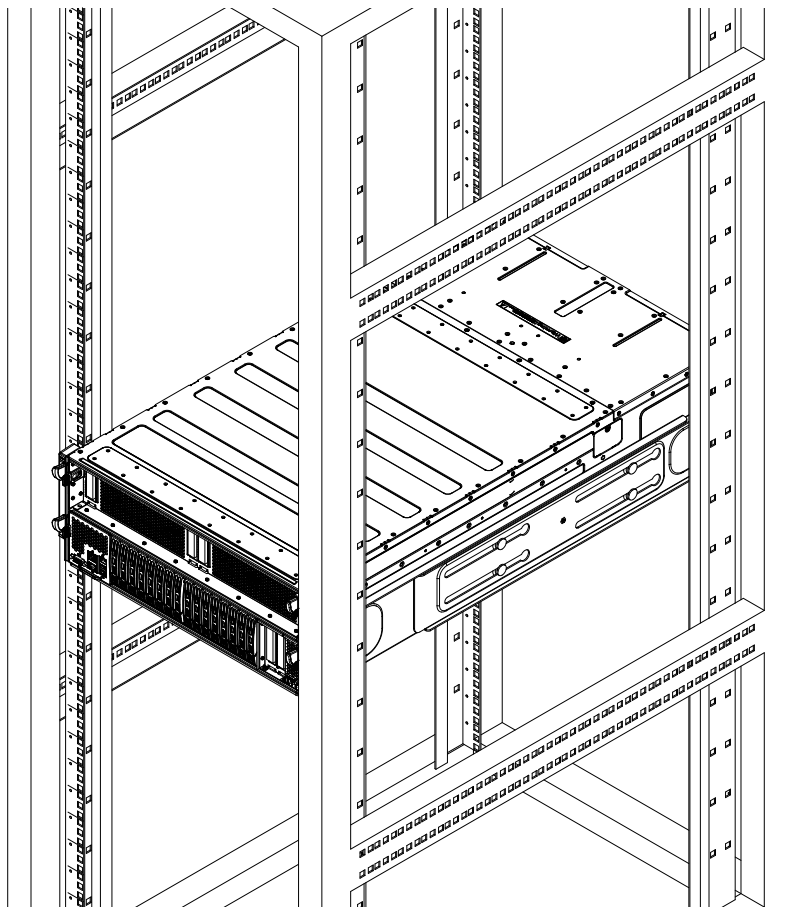

Figure 2-3. Sliding the Chassis into the Rack



Stability hazard. The rack stabilizing mechanism must be in place, or the rack must be bolted to the floor before you slide the unit out for servicing. Failure to stabilize the rack can cause the rack to tip over.

Do not use a two post "telco" type rack.

Chapter 3

System Interface

3-1 Overview

The server includes a control panel on the front that houses power buttons and status monitoring lights. The externally accessible hard drives display status lights. The power supply displays status lights visible from the back of the chassis.

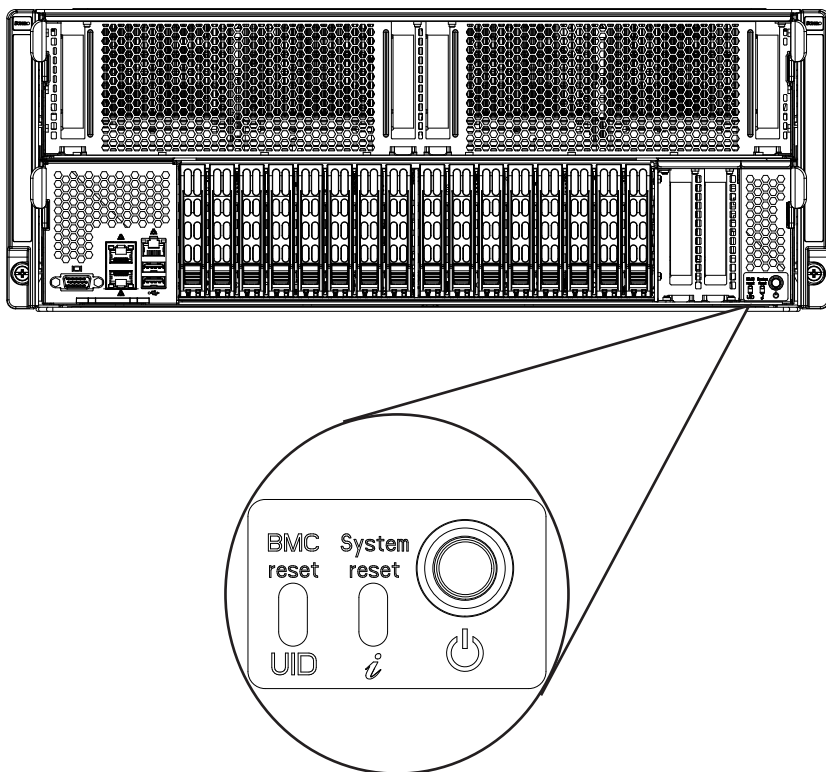

Figure 3-1. Front Control Panel

3-2 Control Panel Buttons/Indicators

The chassis includes three push-buttons that control the system.



Power

The main power switch applies or removes primary power to the server; standby power is maintained. It is green when the system is operating. It is amber when the system is off, but the power supplies are still connected and providing standby power.

System Reset Button/Information LED

The reset button is used to reboot the server. The LED indicator in the button alerts an operator to several states, as noted in the table below



| Information LED | |
|-------------------------|---|
| Status | Description |
| Continuously on and red | An overheat condition has occurred. (See next section) |
| Blinking red (1Hz) | Fan failure, check for an inoperative fan. |
| Blinking red (0.25Hz) | Power failure, check for a non-operational power supply. |
| Solid blue | Local UID has been activated. Use this function to locate the server in a rack mount environment. |
| Blinking blue | Remote UID is on. Use this function to identify the server from a remote location. |

BMC Reset/UID

This button is dual function, depending on the JBMC_BTN jumper. It either:

- turns on or off the blue unit identifier (UID) light, used to locate the server in large server banks.
- resets the Baseboard Management controller (BMC) that provides IPMI support.

3-3 Overheating

There are several possible responses if the system overheats.

Overheat Temperature Setting

Some backplanes allow the overheat temperature to be set at 45, 50, or 55 by changing a jumper setting. For more information, consult the backplane user manual at www.supermicro.com. (Click Support, then the Manuals link.)

Responses

If the server overheats:

1. Use the LEDs to determine the nature of the overheating condition.
2. Confirm that the chassis covers are installed properly.
3. Check the routing of the cables and make sure all fans are present and operating normally.
4. Verify that the heatsinks are installed properly.

3-4 Drive Carrier LEDs

The chassis includes externally accessible SAS/SATA/NVMe drives. Each drive carrier displays two status LEDs on the front of the carrier.

| | LED Color | Blinking Pattern | Behavior for Device |
|---------------------|------------------|---|---|
| Activity LED | Blue | Blinking | I/O activity |
| | Blue | Solid On | Idle SAS/NVMe drive installed |
| | Off | Off | Idle SATA drive |
| Status LED | Red | Solid On | Failure of drive with RSTe support |
| | Red | Blinking at 1 Hz | Rebuild drive with RSTe support |
| | Red | Blinking with two blinks and one stop at 1 Hz | Hot spare for drive with RSTe support |
| | Red | On for five seconds, then off | Power on for drive with RSTe support |
| | Red | Blinking at 4 Hz | Identify drive with RSTe support |
| | Green | Solid On | Safe to remove NVMe device |
| | Amber | Blinking at 1 Hz | Attention state—do not remove NVMe device |

3-5 Power Supply LEDs

On the rear of the power supply module, an LED displays the status.

- **Solid Green:** When illuminated, indicates that the power supply is on.
- **Solid Amber:** When illuminated, indicates the power supply is plugged in and turned off, or the system is off but in an abnormal state.
- **Blinking Amber:** When blinking, this system power supply temperature has reached 63C. The system will automatically power-down when the power supply temperature reaches 70C and restart when the power supply temperature goes below 60C.

Chapter 4

Standardized Warning Statements for AC Systems

About Standardized Warning Statements

The following statements are industry standard warnings, provided to warn the user of situations which have the potential for bodily injury. Should you have questions or experience difficulty, contact Supermicro's Technical Support department for assistance. Only certified technicians should attempt to install or configure components.

Read this chapter in its entirety before installing or configuring components in the Supermicro chassis. Some warnings may not apply for your system.

These warnings may also be found on our web site at www.supermicro.com/about/policies/safety_information.cfm.

Warning Definition



Warning!

This warning symbol means danger. You are in a situation that could cause bodily injury. Before you work on any equipment, be aware of the hazards involved with electrical circuitry and be familiar with standard practices for preventing accidents.

警告の定義

この警告サインは危険を意味します。

人身事故につながる可能性がありますので、いずれの機器でも動作させる前に、電気回路に含まれる危険性に注意して、標準的な事故防止策に精通して下さい。

此警告符号代表危險。

您正处于可能受到严重伤害的工作环境中。在您使用设备开始工作之前，必须充分意识到触电的危险，并熟练掌握防止事故发生的标准工作程序。请根据每项警告结尾的声明号码找到此设备的安全性警告说明的翻译文本。

此警告符号代表危險。

您目前所處的工作環境可能讓您受傷。您使用任何設備之前，請注意觸電的危險，並且要熟悉預防事故發生的標準工作程序。請依照每一注意事項後的號碼找到相關的翻譯說明內容。

Warnung

WICHTIGE SICHERHEITSHINWEISE

Dieses Warnsymbol bedeutet Gefahr. Sie befinden sich in einer Situation, die zu Verletzungen führen kann. Machen Sie sich vor der Arbeit mit Geräten mit den Gefahren elektrischer Schaltungen und den üblichen Verfahren zur Vorbeugung vor Unfällen vertraut. Suchen Sie mit der am Ende jeder Warnung angegebenen Anweisungsnummer nach der jeweiligen Übersetzung in den übersetzten Sicherheitshinweisen, die zusammen mit diesem Gerät ausgeliefert wurden.

BEWAHREN SIE DIESE HINWEISE GUT AUF.

INSTRUCCIONES IMPORTANTES DE SEGURIDAD

Este símbolo de aviso indica peligro. Existe riesgo para su integridad física. Antes de manipular cualquier equipo, considere los riesgos de la corriente eléctrica y familiarícese con los procedimientos estándar de prevención de accidentes. Al final de cada advertencia encontrará el número que le ayudará a encontrar el texto traducido en el apartado de traducciones que acompaña a este dispositivo.

GUARDE ESTAS INSTRUCCIONES.

IMPORTANTES INFORMATIONS DE SÉCURITÉ

Ce symbole d'avertissement indique un danger. Vous vous trouvez dans une situation pouvant entraîner des blessures ou des dommages corporels. Avant de travailler sur un équipement, soyez conscient des dangers liés aux circuits électriques et familiarisez-vous avec les procédures couramment utilisées pour éviter les accidents. Pour prendre connaissance des traductions des avertissements figurant dans les consignes de sécurité traduites qui accompagnent cet appareil, référez-vous au numéro de l'instruction situé à la fin de chaque avertissement.

CONSERVEZ CES INFORMATIONS.

תקנת הצהרות אזהרה

הצהרות הבאות הן אזהרות על פי תקני התעשייה, על מנת להזהיר את המשתמש מפני חבלה פיזית אפשרית. במידה ויש שאלות או היתקלות בבעיה כלשהי, יש ליצור קשר עם מחלקת תמיכה טכנית של סופרמיקרו. טכנאים מוסמכים בלבד רשאים להתקין או להגדיר את הרכיבים.

יש לקרוא את הנספח במלואו לפני התקנת או הגדרת הרכיבים במארוי סופרמיקרו.

تحذير! هذا الرمز يعني خطر انك في حالة يمكن أن تتسبب في اصابة جسدية .
قبل أن تعمل على أي معدات، كن على علم بالمخاطر الناجمة عن الدوائر
الكهربائية
وكن على دراية بالممارسات الوقائية لمنع وقوع أي حوادث
استخدم رقم البيان المنصوص في نهاية كل تحذير للعثور ترجمتها

안전을 위한 주의사항

경고!

이 경고 기호는 위험이 있음을 알려 줍니다. 작업자의 신체에 부상을 야기 할 수 있는 상태에 있게 됩니다. 모든 장비에 대한 작업을 수행하기 전에 전기회로와 관련된 위험요소들을 확인하시고 사전에 사고를 방지할 수 있도록 표준 작업절차를 준수해 주시기 바랍니다.

해당 번역문을 찾기 위해 각 경고의 마지막 부분에 제공된 경고문 번호를 참조하십시오

BELANGRIJKE VEILIGHEIDSINSTRUCTIES

Dit waarschuwings symbool betekent gevaar. U verkeert in een situatie die lichamelijk letsel kan veroorzaken. Voordat u aan enige apparatuur gaat werken, dient u zich bewust te zijn van de bij een elektrische installatie betrokken risico's en dient u op de hoogte te zijn van de standaard procedures om ongelukken te voorkomen. Gebruik de nummers aan het eind van elke waarschuwing om deze te herleiden naar de desbetreffende locatie.

BEWAAR DEZE INSTRUCTIES

Installation Instructions



Warning!

Read the installation instructions before connecting the system to the power source.

設置手順書

システムを電源に接続する前に、設置手順書をお読み下さい。

警告

将此系统连接电源前，请先阅读安装说明。

警告

將系統與電源連接前，請先閱讀安裝說明。

Warnung

Vor dem Anschließen des Systems an die Stromquelle die Installationsanweisungen lesen.

¡Advertencia!

Lea las instrucciones de instalación antes de conectar el sistema a la red de alimentación.

Attention

Avant de brancher le système sur la source d'alimentation, consulter les directives d'installation.

יש לקרוא את הוראות התקנה לפני חיבור המערכת למקור מתח.

اقرأ إرشادات التركيب قبل توصيل النظام إلى مصدر للطاقة

시스템을 전원에 연결하기 전에 설치 안내를 읽어주십시오.

Waarschuwing

Raadpleeg de installatie-instructies voordat u het systeem op de voedingsbron aansluit.

Circuit Breaker



Warning!

This product relies on the building's installation for short-circuit (overcurrent) protection. Ensure that the protective device is rated not greater than: 250 V, 20 A.

サーキット・ブレーカー

この製品は、短絡(過電流)保護装置がある建物での設置を前提としています。

保護装置の定格が250 V、20 Aを超えないことを確認下さい。

警告

此产品的短路(过载电流)保护由建筑物的供电系统提供,确保短路保护设备的额定电流不大于250V,20A。

警告

此产品的短路(过载电流)保护由建筑物的供电系统提供,确保短路保护设备的额定电流不大于250V,20A。

Warnung

Dieses Produkt ist darauf angewiesen, dass im Gebäude ein Kurzschluss- bzw. Überstromschutz installiert ist. Stellen Sie sicher, dass der Nennwert der Schutzvorrichtung nicht mehr als: 250 V, 20 A beträgt.

¡Advertencia!

Este equipo utiliza el sistema de protección contra cortocircuitos (o sobrecorrientes) del edificio. Asegúrese de que el dispositivo de protección no sea superior a: 250 V, 20 A.

Attention

Pour ce qui est de la protection contre les courts-circuits (surtension), ce produit dépend de l'installation électrique du local. Vérifiez que le courant nominal du dispositif de protection n'est pas supérieur à :250 V, 20 A.

מוצר זה מסתמך על הגנה המותקנת במבנים למניעת קצר חשמלי. יש לוודא כי המכשיר המגן מפני הקצר החשמלי הוא לא יותר מ-250 V, 20 A

هذا المنتج يعتمد على معدات الحماية من الدوائر القصيرة التي تم تثبيتها في المبنى

تأكد من أن تقييم الجهاز الوقائي ليس أكثر من: 20A, 250V

경고!

이 제품은 전원의 단락(과전류)방지에 대해서 전적으로 건물의 관련 설비에 의존합니다. 보호장치의 정격이 반드시 250V(볼트), 20A(암페어)를 초과하지 않도록 해야 합니다.

Waarschuwing

Dit product is afhankelijk van de kortsluitbeveiliging (overspanning) van uw elektrische installatie. Controleer of het beveiligde apparaat niet groter gedimensioneerd is dan 220V, 20A.

Power Disconnection Warning



Warning!

The system must be disconnected from all sources of power and the power cord removed from the power supply module(s) before accessing the chassis interior to install or remove system components.

電源切斷の警告

システムコンポーネントの取り付けまたは取り外しのために、シャーシ内部にアクセスするには、システムの電源はすべてのソースから切斷され、電源コードは電源モジュールから取り外す必要があります。

警告

在你打开机箱并安装或移除内部器件前，必须将系统完全断电，并移除电源线。

警告

在您打開機殼安裝或移除內部元件前，必須將系統完全斷電，並移除電源線。

Warnung

Das System muss von allen Quellen der Energie und vom Netzanschlusskabel getrennt sein, das von den Spg.Versorgungsteilmodulen entfernt wird, bevor es auf den Chassisinnenraum zurückgreift, um Systemsbestandteile anzubringen oder zu entfernen.

¡Advertencia!

El sistema debe ser disconnected de todas las fuentes de energía y del cable eléctrico quitado de los módulos de fuente de alimentación antes de tener acceso el interior del chasis para instalar o para quitar componentes de sistema.

Attention

Le système doit être débranché de toutes les sources de puissance ainsi que de son cordon d'alimentation secteur avant d'accéder à l'intérieur du châssis pour installer ou enlever des composants de système.

אזהרה!

יש לנתק את המערכת מכל מקורות החשמל ויש להסיר את כבל החשמלי מהספק לפני גישה לחלק הפנימי של המארז לצורך התקנת או הסרת רכיבים.

يجب فصل النظام من جميع مصادر الطاقة وإزالة سلك الكهرباء من وحدة امداد الطاقة قبل الوصول إلى المناطق الداخلية للهيكल لتثبيت أو إزالة مكونات الجهاز

경고!

시스템에 부품들을 장착하거나 제거하기 위해서는 새시 내부에 접근하기 전에 반드시 전원 공급장치로부터 연결되어있는 모든 전원과 전기코드를 분리해주어야 합니다.

Waarschuwing

Voordat u toegang neemt tot het binnenwerk van de behuizing voor het installeren of verwijderen van systeem onderdelen, dient u alle spanningsbronnen en alle stroomkabels aangesloten op de voeding(en) van de behuizing te verwijderen

Equipment Installation



Warning!

Only trained and qualified personnel should be allowed to install, replace, or service this equipment.

機器の設置

トレーニングを受け認定された人だけがこの装置の設置、交換、またはサービスを許可されています。

警告

只有经过培训且具有资格的人员才能进行此设备的安装、更换和维修。

警告

只有經過受訓且具資格人員才可安裝、更換與維修此設備。

Warnung

Das Installieren, Ersetzen oder Bedienen dieser Ausrüstung sollte nur geschultem, qualifiziertem Personal gestattet werden.

¡Advertencia!

Solamente el personal calificado debe instalar, reemplazar o utilizar este equipo.

Attention

Il est vivement recommandé de confier l'installation, le remplacement et la maintenance de ces équipements à des personnels qualifiés et expérimentés.

אזהרה!

צוות מוסמך בלבד רשאי להתקין, להחליף את הציוד או לתת שירות עבור הציוד.

يجب أن يسمح فقط للموظفين المؤهلين والمدربين لتثبيت واستبدال أو خدمة هذا الجهاز

경고!

훈련을 받고 공인된 기술자만이 이 장비의 설치, 교체 또는 서비스를 수행할 수 있습니다.

Waarschuwing

Deze apparatuur mag alleen worden geïnstalleerd, vervangen of hersteld door geschoold en gekwalificeerd personeel.

Restricted Area



Warning!

This unit is intended for installation in restricted access areas. A restricted access area can be accessed only through the use of a special tool, lock and key, or other means of security. (This warning does not apply to workstations).

アクセス制限区域

このユニットは、アクセス制限区域に設置されることを想定しています。

アクセス制限区域は、特別なツール、鍵と錠前、その他のセキュリティの手段を用いてのみ出入りが可能です。

警告

此部件应安装在限制进出的场所，限制进出的场所指只能通过使用特殊工具、锁和钥匙或其它安全手段进出的场所。

警告

此裝置僅限安裝於進出管制區域，進出管制區域係指僅能以特殊工具、鎖頭及鑰匙或其他安全方式才能進入的區域。

Warnung

Diese Einheit ist zur Installation in Bereichen mit beschränktem Zutritt vorgesehen. Der Zutritt zu derartigen Bereichen ist nur mit einem Spezialwerkzeug, Schloss und Schlüssel oder einer sonstigen Sicherheitsvorkehrung möglich.

¡Advertencia!

Esta unidad ha sido diseñada para instalación en áreas de acceso restringido. Sólo puede obtenerse acceso a una de estas áreas mediante la utilización de una herramienta especial, cerradura con llave u otro medio de seguridad.

Attention

Cet appareil doit être installée dans des zones d'accès réservés. L'accès à une zone d'accès réservé n'est possible qu'en utilisant un outil spécial, un mécanisme de verrouillage et une clé, ou tout autre moyen de sécurité.

אזור עם גישה מוגבלת

!אזהרה!

יש להתקין את היחידה באזורים שיש בהם הגבלת גישה. הגישה ניתנת בעזרת כלי אבטחה בלבד (מפתח, מנעול וכד').

تم تخصيص هذه الوحدة لت تركيبها في مناطق محظورة .
يمكن الوصول إلى منطقة محظورة فقط من خلال استخدام أداة خاصة،
قفل ومفتاح أو أي وسيلة أخرى للالأمان

경고!

이 장치는 접근이 제한된 구역에 설치하도록 되어 있습니다. 특수도구, 잠금 장치 및 키, 또는 기타 보안 수단을 통해서만 접근 제한 구역에 들어갈 수 있습니다.

Waarschuwing

Dit apparaat is bedoeld voor installatie in gebieden met een beperkte toegang. Toegang tot dergelijke gebieden kunnen alleen verkregen worden door gebruik te maken van speciaal gereedschap, slot en sleutel of andere veiligheidsmaatregelen.

Battery Handling



Warning!

There is the danger of explosion if the battery is replaced incorrectly. Replace the battery only with the same or equivalent type recommended by the manufacturer. Dispose of used batteries according to the manufacturer's instructions

電池の取り扱い

電池交換が正しく行われなかった場合、破裂の危険性があります。交換する電池はメーカーが推奨する型、または同等のものを使用下さい。使用済電池は製造元の指示に従って処分して下さい。

警告

電池更換不當會有爆炸危險。請只使用同類電池或製造商推薦的功能相當的電池更換原有電池。請按製造商的說明處理廢舊電池。

警告

電池更換不當會有爆炸危險。請使用製造商建議之相同或功能相當的電池更換原有電池。請按照製造商的說明指示處理廢棄舊電池。

Warnung

Bei Einsetzen einer falschen Batterie besteht Explosionsgefahr. Ersetzen Sie die Batterie nur durch den gleichen oder vom Hersteller empfohlenen Batterietyp. Entsorgen Sie die benutzten Batterien nach den Anweisungen des Herstellers.

Attention

Danger d'explosion si la pile n'est pas remplacée correctement. Ne la remplacer que par une pile de type semblable ou équivalent, recommandée par le fabricant. Jeter les piles usagées conformément aux instructions du fabricant.

¡Advertencia!

Existe peligro de explosión si la batería se reemplaza de manera incorrecta. Reemplazar la batería exclusivamente con el mismo tipo o el equivalente recomendado por el fabricante. Desechar las baterías gastadas según las instrucciones del fabricante.

אזהרה!

קיימת סכנת פיצוץ של הסוללה במידה והוחלפה בדרך לא תקינה. יש להחליף את הסוללה בסוג התואם מחברת יצרן מומלצת.

סילוק הסוללות המשומשות יש לבצע לפי הוראות היצרן.

هناك خطر من انفجار في حالة استبدال البطارية بطريقة غير صحيحة فعليك استبدال البطارية فقط بنفس النوع أو ما يعادلها كما أوصت به الشركة المصنعة تخلص من البطاريات المستعملة وفقا لتعليمات الشركة الصانعة

경고!

배터리가 올바르게 교체되지 않으면 폭발의 위험이 있습니다. 기존 배터리와 동일하거나 제조사에서 권장하는 동등한 종류의 배터리로만 교체해야 합니다. 제조사의 안내에 따라 사용된 배터리를 처리하여 주십시오.

Waarschuwing

Er is ontploffingsgevaar indien de batterij verkeerd vervangen wordt. Vervang de batterij slechts met hetzelfde of een equivalent type die door de fabrikant aanbevolen wordt. Gebruikte batterijen dienen overeenkomstig fabrieksvoorschriften afgevoerd te worden.

Redundant Power Supplies (if applicable to your system)



Warning!

This unit might have more than one power supply connection. All connections must be removed to de-energize the unit.

冗長電源装置

このユニットは複数の電源装置が接続されている場合があります。
ユニットの電源を切るためには、すべての接続を取り外さなければなりません。

警告

此部件连接的电源可能不止一个，必须将所有电源断开才能停止给该部件供电。

警告

此装置连接的電源可能不只一個，必須切斷所有電源才能停止對該裝置的供電。

Warnung

Dieses Gerät kann mehr als eine Stromzufuhr haben. Um sicherzustellen, dass der Einheit kein Strom zugeführt wird, müssen alle Verbindungen entfernt werden.

¡Advertencia!

Puede que esta unidad tenga más de una conexión para fuentes de alimentación. Para cortar por completo el suministro de energía, deben desconectarse todas las conexiones.

Attention

Cette unité peut avoir plus d'une connexion d'alimentation. Pour supprimer toute tension et tout courant électrique de l'unité, toutes les connexions d'alimentation doivent être débranchées.

אם קיים יותר מספק אחד

אזהרה!

ליחידה יש יותר מחיבור אחד של ספק. יש להסיר את כל החיבורים על מנת לרוקן את היחידה.

قد يكون لهذا الجهاز عدة اتصالات بوحدات امداد الطاقة.
يجب إزالة كافة الاتصالات لعزل الوحدة عن الكهرباء

경고!

이 장치에는 한 개 이상의 전원 공급 단자가 연결되어 있을 수 있습니다. 이 장치에 전원을 차단하기 위해서는 모든 연결 단자를 제거해야만 합니다.

Waarschuwing

Deze eenheid kan meer dan één stroomtoevoeraansluiting bevatten. Alle aansluitingen dienen verwijderd te worden om het apparaat stroomloos te maken.

Backplane Voltage (if applicable to your system)



Warning!

Hazardous voltage or energy is present on the backplane when the system is operating. Use caution when servicing.

バックプレーンの電圧

システムの稼働中は危険な電圧または電力が、バックプレーン上にかかっています。

修理する際にはご注意ください。

警告

当系统正在进行时，背板上有很危险的电压或能量，进行维修时务必小心。

警告

當系統正在進行時，背板上有危險的電壓或能量，進行維修時務必小心。

Warnung

Wenn das System in Betrieb ist, treten auf der Rückwandplatine gefährliche Spannungen oder Energien auf. Vorsicht bei der Wartung.

¡Advertencia!

Cuando el sistema está en funcionamiento, el voltaje del plano trasero es peligroso. Tenga cuidado cuando lo revise.

Attention

Lorsque le système est en fonctionnement, des tensions électriques circulent sur le fond de panier. Prendre des précautions lors de la maintenance.

מתח בפנל האחורי

אזהרה!
קיימת סכנת מתח בפנל האחורי בזמן תפעול המערכת. יש להיזהר במהלך העבודה.

هناك خطر من التيار الكهربائي أو الطاقة الموجودة على اللوحة
عندما يكون النظام يعمل كن حذرا عند خدمة هذا الجهاز

경고!

시스템이 동작 중일 때 후면판 (Backplane)에는 위험한 전압이나 에너지가 발생
합니다. 서비스 작업 시 주의하십시오.

Waarschuwing

Een gevaarlijke spanning of energie is aanwezig op de backplane wanneer het
systeem in gebruik is. Voorzichtigheid is geboden tijdens het onderhoud.

Comply with Local and National Electrical Codes



Warning!

Installation of the equipment must comply with local and national electrical codes.

地方および国の電気規格に準拠

機器の取り付けはその地方および国の電気規格に準拠する必要があります。

警告

设备安装必须符合本地与本国电气法规。

警告

設備安裝必須符合本地與本國電氣法規。

Warnung

Die Installation der Geräte muss den Sicherheitsstandards entsprechen.

¡Advertencia!

La instalación del equipo debe cumplir con las normas de electricidad locales y
nacionales.

Attention

L'équipement doit être installé conformément aux normes électriques nationales et locales.

תיאום חוקי החשמל הארצי

אזהרה!

התקנת הציוד חייבת להיות תואמת לחוקי החשמל המקומיים והארציים.

تركيب المعدات الكهربائية يجب أن يمتثل للقوانين المحلية والوطنية المتعلقة بالكهرباء

경고!

현 지역 및 국가의 전기 규정에 따라 장비를 설치해야 합니다.

Waarschuwing

Bij installatie van de apparatuur moet worden voldaan aan de lokale en nationale elektriciteitsvoorschriften.

Product Disposal



Warning!

Ultimate disposal of this product should be handled according to all national laws and regulations.

製品の廃棄

この製品を廃棄処分する場合、国の関係する全ての法律・条例に従い処理する必要があります。

警告

本产品的废弃处理应根据所有国家的法律和规章进行。

警告

本產品的廢棄處理應根據所有國家的法律和規章進行。

Warnung

Die Entsorgung dieses Produkts sollte gemäß allen Bestimmungen und Gesetzen des Landes erfolgen.

¡Advertencia!

Al deshacerse por completo de este producto debe seguir todas las leyes y reglamentos nacionales.

Attention

La mise au rebut ou le recyclage de ce produit sont généralement soumis à des lois et/ou directives de respect de l'environnement. Renseignez-vous auprès de l'organisme compétent.

סילוק המוצר

אזהרה!

סילוק סופי של מוצר זה חייב להיות בהתאם להנחיות וחוקי המדינה.

عند التخلص النهائي من هذا المنتج ينبغي التعامل معه وفقا لجميع القوانين واللوائح الوطنية

경고!

이 제품은 해당 국가의 관련 법규 및 규정에 따라 폐기되어야 합니다.

Waarschuwing

De uiteindelijke verwijdering van dit product dient te geschieden in overeenstemming met alle nationale wetten en reglementen.

Hot Swap Fan Warning



Warning!



Hazardous moving parts. Keep away from moving fan blades. The fans might still be turning when you remove the fan assembly from the chassis. Keep fingers, screwdrivers, and other objects away from the openings in the fan assembly's housing.

ファン・ホットスワップの警告

警告!回転部品に注意。運転中は回転部(羽根)に触れないでください。シャーシから冷却ファン装置を取り外した際、ファンがまだ回転している可能性があります。ファンの開口部に、指、ドライバー、およびその他のものを近づけないで下さい。

警告!

警告! 危险的可移动性零件。请务必与转动的风扇叶片保持距离。当您从机架移除风扇装置, 风扇可能仍在转动。小心不要将手指、螺丝起子和其他物品太靠近风扇

警告

危險的可移動性零件。請務必與轉動的風扇葉片保持距離。當您從機架移除風扇裝置，風扇可能仍在轉動。小心不要將手指、螺絲起子和其他物品太靠近風扇。

Warnung

Gefährlich Bewegende Teile. Von den bewegenden Lüfterblätter fern halten. Die Lüfter drehen sich u. U. noch, wenn die Lüfterbaugruppe aus dem Chassis genommen wird. Halten Sie Finger, Schraubendreher und andere Gegenstände von den Öffnungen des Lüftergehäuses entfernt.

¡Advertencia!

Riesgo de piezas móviles. Mantener alejado de las aspas del ventilador. Los ventiladores podran dar vuelta cuando usted quite el montaje del ventilador del chasis. Mandtenga los dedos, los destornilladores y todos los objetos lejos de las aberturas del ventilador

Attention

Pieces mobiles dangereuses. Se tenir a l'ecart des lames du ventilateur Il est possible que les ventilateurs soient toujours en rotation lorsque vous retirerez le bloc ventilateur du châssis. Prenez garde à ce que doigts, tournevis et autres objets soient éloignés du logement du bloc ventilateur.

!הרה'

קים נעים מסוכנים. התרחק מלהבי המאוורר בפעולהכאשר מסירים את חלקי אוורר מהמארוז, יתכן והמאווררים עדיין עובדים. יש להרחיק למרחק בטוח את

تحذير! أجزاء متحركة خطيرة. ابتعد عن شفرات المروحة المتحركة من الممكن أن المراوح لا تزال تدور عند إزالة كتلة المروحة من الهيكل يجب إبقاء الأصابع ومفكات البراغي وغيرها من الأشياء بعيدا عن الفتحات في كتلة المروحة.

경고!

움직이는 위험한 부품. 회전하는 송풍 날개에 접근하지 마세요. 새시로부터 팬 조립품을 제거할 때 팬은 여전히 회전하고 있을 수 있습니다. 팬 조립품 외관의 열려있는 부분들로부터 손가락 및 스크류드라이버, 다른 물체들이 가까이 하지 않도록 배치해 주십시오.

Waarschuwing

Gevaarlijk bewegende onderdelen. Houd voldoende afstand tot de bewegende ventilatorbladen. Het is mogelijk dat de ventilator nog draait tijdens het verwijderen van het ventilatorsamenstel uit het chassis. Houd uw vingers, schroevendraaiers en eventuele andere voorwerpen uit de buurt van de openingen in de ventilatorbehuizing.

Power Cable and AC Adapter



Warning!

Warning! When installing the product, use the provided or designated connection or procure cables, power cables and AC adaptors complying with local codes and safety requirements including proper cord size and plug. Using any other cables and adaptors could cause a malfunction or a fire. Electrical Appliance and Material Safety Law prohibits the use of UL or CSA -certified cables (that have UL/CSA shown on the code) for any other electrical devices than products designated by Supermicro only..

電源コードとACアダプター

製品を設置する場合、提供または指定および購入された接続ケーブル、電源コードとACアダプターを、該当する地域の条例や安全基準に適合するコードサイズやプラグと共に使用下さい。他のケーブルやアダプタを使用すると故障や火災の原因になることがあります。電気用品安全法は、ULまたはCSA認定のケーブル(UL/CSEマークがコードに表記)を Supermicroが指定する製品以外に使用することを禁止しています。

警告

安裝此產品時，請使用本身提供的或指定的或採購的連接線，電源線和電源適配器，包含遵照當地法規和安全要求的合規的電源線尺寸和插頭。使用其它線材或適配器可能會引起故障或火災。除了 Supermicro 所指定的產品，電氣用品和材料安全法律規定禁止 使用未經 UL 或 CSA 認證的線材。（線材上會顯示 UL/CSA 符號）。

警告

安裝此產品時，請使用本身提供的或指定的或採購的連接線，電源線和電源適配器，包含遵照當地法規和安全要求的合規的電源線尺寸和插頭。使用其它線材或適配器可能會引起故障或火災。除了 Supermicro 所指定的產品，電氣用品和材料安全法律規定禁止 使用未經 UL 或 CSA 認證的線材。（線材上會顯示 UL/CSA 符號）。

Warnung

Nutzen Sie beim Installieren des Produkts ausschließlich die von uns zur Verfügung gestellten Verbindungskabeln, Stromkabeln und/oder Adapter, die Ihre örtlichen Sicherheitsstandards einhalten. Der Gebrauch von anderen Kabeln und Adapter können Fehlfunktionen oder Feuer verursachen. Die Richtlinien untersagen das Nutzen von UL oder CAS zertifizierten Kabeln (mit UL/CSA gekennzeichnet), an Geräten oder Produkten die nicht mit Supermicro gekennzeichnet sind.

¡Advertencia!

Cuando instale el producto, utilice la conexión provista o designada o procure cables, Cables de alimentación y adaptadores de CA que cumplan con los códigos locales y los requisitos de seguridad, incluyendo el tamaño adecuado del cable y el enchufe. El uso de otros cables y adaptadores podría causar un mal funcionamiento o un incendio. La Ley de Seguridad de Aparatos Eléctricos y de Materiales prohíbe El uso de cables certificados por UL o CSA (que tienen el certificado UL / CSA en el código) para cualquier otros dispositivos eléctricos que los productos designados únicamente por Supermicro.Attention

Attention

Lors de l'installation du produit, utilisez les cables de connection fournis ou désigné ou achetez des cables, cables de puissance et adaptateurs respectant les normes locales et les conditions de securite y compris les tailles de cables et les prises electriques appropriées. L'utilisation d'autres cables et adaptateurs peut provoquer un dysfonctionnement ou un incendie. Appareils électroménagers et la Loi sur la Sécurité Matériel interdit l'utilisation de câbles certifiés- UL ou CSA (qui ont UL ou CSA indiqué sur le code) pour tous les autres appareils électriques sauf les produits désignés par Supermicro seulement.

AC ימאתמו םיילמשח םילבכ

!הרהזא

וא ושכרנ רשא AC םימאתמו םיקפס, םילבכב שמתשהל שי, רצומה תא םיניקתמ רשאכ לש הנוכנ הדימ ללוכ, תוימוקמה תוחיטבה תושידל ומאתוה רשאו, הנקתהה ךרוצל ומאתוה ילמשח רצק וא הלקתל מורגל לולע, רחא גוסמ מאתמ וא לבכ לכב שומיש . עקתוה לבכה םילבכב שמתשהל רוסיא םייק, תוחיטבה יקוחו למשחה ירישכמב שומישה יקוחל מאתהב ילמשח רצומ לכ רובע (UL/CSA) לש דוק מהילע עיפומ רשאכ) UL-CSA ב- וא UL ב- םיכמוסמה דבלב Supermicro י"ע מאתוה רשא רצומב קר אלא, רחא

תאלבאלא אארשב חק וא קדדחמל וא תרפוטחמל תאליוטותל אדחסתסאב חק, חגתחמל אביקרת דנע אב עילחמל אקמלסל תאבלטתמו נינאווקב מאזתלאל אע דדרתמל ראיתל תאלוחמו עייתאברמל א יפ בבסתטי דק ירזח תאלוחמו תאלבא יא אדחסתסא. מילסל סבאקלאו לטוחמל אגח אכלז יפ קדמתחמל תאלבאלא אדחסתסא תאדחמל או עייתאברמל אקזחאלל אקמלסל אנונאק רזחטי. קיירזח וא לטע עייתחמל תאחגתחמל רייג ירזחא תאדעמ יא אע (UL/CSA) אקמלע למחתי יתלאו CSA וא UL לבק נמ Supermicro לבק נמ קדדחמלאו

전원 케이블 및 AC 어댑터

경고! 제품을 설치할 때 현지 코드 및 적절한 굵기의 코드와 플러그를 포함한 안전 요구 사항을 준수하여 제공되거나 지정된 연결 혹은 구매 케이블, 전원 케이블 및 AC 어댑터를 사용하십시오.

다른 케이블이나 어댑터를 사용하면 오작동이나 화재가 발생할 수 있습니다. 전기 용품 안전법은 UL 또는 CSA 인증 케이블 (코드에 UL / CSA가 표시된 케이블) 을 Supermicro가 지정한 제품 이외의 전기 장치에 사용하는 것을 금지합니다.

Stroomkabel en AC-Adapter

Waarschuwing! Bij het aansluiten van het Product uitsluitend gebruik maken van de geleverde Kabels of een andere geschikte aan te schaffen Aansluitmethode, deze moet altijd voldoen aan de lokale voorschriften en veiligheidsnormen, inclusief de juiste kabeldikte en stekker. Het gebruik van niet geschikte Kabels en/of Adapters kan een storing of brand veroorzaken. Wetgeving voor Elektrische apparatuur en Materiaalveiligheid verbied het gebruik van UL of CSA -gecertificeerde Kabels (met UL/CSA in de code) voor elke andere toepassing dan de door Supermicro hiervoor beoogde Producten.

Chapter 5

Advanced Motherboard Setup

This chapter covers connecting cables and describes jumpers. A layout and quick reference chart are included.

The 4028GR-TXR uses the X10DGO motherboard, and the 4028GR-TXRT uses the X10DGO-T motherboard. They are used in tandem with the X10DGO-SXM plate for eight Pascal SXM GPUs.

5-1 Handling the Motherboard

Electrostatic Discharge (ESD) can damage electronic components. To prevent damage to any printed circuit boards (PCBs), it is important to handle them very carefully (see previous chapter). To prevent the motherboard from bending, keep one hand under the center of the board to support it when handling. The following measures are generally sufficient to protect your equipment from electric static discharge.

Precautions

- Use a grounded wrist strap designed to prevent Electrostatic Discharge (ESD).
- Touch a grounded metal object before removing any board from its antistatic bag.
- Handle a board by its edges only; do not touch its components, peripheral chips, memory modules or gold contacts.
- When handling chips or modules, avoid touching their pins.
- Put the motherboard, add-on cards and peripherals back into their antistatic bags when not in use.
- For grounding purposes, make sure your computer chassis provides excellent conductivity between the power supply, the case, the mounting fasteners and the motherboard.

Unpacking

The motherboard is shipped in antistatic packaging to avoid electrical static discharge. When unpacking the board, make sure the person handling it is static protected.

5-2 Connecting Cables

As this server is delivered only as a complete system, cables are already routed.

Data Cables

The ribbon cables used to transfer data from the peripheral devices have been carefully routed to prevent them from blocking the flow of cooling air that moves through the system. If you disconnect any of these cables, take care to route as they were originally after reconnecting them. Make sure the red wires connect to the pin 1 locations.

Important! Make sure the the cables do not come into contact with the fans.

Power Cables

The motherboard has several power connectors. See Section 5-7 for power connector pin definitions.

5-3 Input/Output Ports

Input/output ports are located on the front of the chassis.

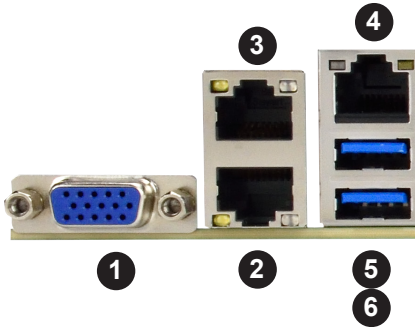

Figure 5-1. I/O Ports

| | |
|------------------|----------------------------|
| 1. VGA Connector | 4. Dedicated IPMI LAN Port |
| 2. LAN1 | 5. USB2 (3.0) |
| 3. LAN2 | 6. USB3 (3.0) |

For X10DGO the LAN ports are 1Gb; for X10DGO-T the LAN ports are 10Gb.

5-4 Installing the Processor and Heatsink

Notes:

- Always remove the power cord before adding, removing or changing a CPU.
- When receiving a motherboard without a processor pre-installed, make sure that the plastic CPU socket cap is in place and none of the socket pins are bent; otherwise, contact your retailer immediately.
- If you buy a CPU separately, use only an Intel-certified, multi-directional heatsink.
- Avoid placing direct pressure to the top of the processor package.
- Install the processor into the CPU socket before installing the heatsink.
- Refer to the Supermicro web site for updates on CPU support.

Installing an LGA 2011 Processor

Installing a CPU

1. There are two levers on the LGA 2011 socket. First press and release the load lever labeled "Open 1st".

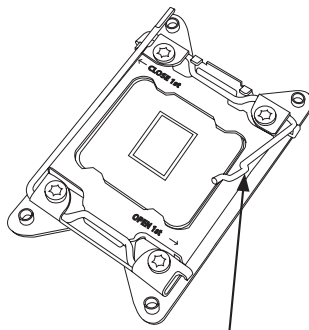

Release the lever labeled "Open 1st"

2. Press the second load lever labeled "Close 1st" to release the load plate from its locked position.

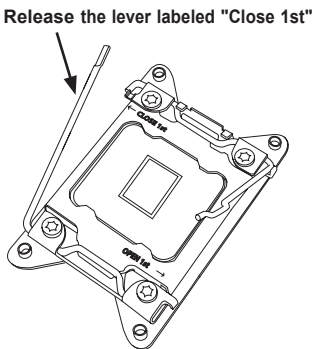

Release the lever labeled "Close 1st"

3. With the second lever fully retracted, gently push down on the "Open 1st" lever to loosen the load plate. Lift the load plate with your fingers to open it completely.

Open the load plate.

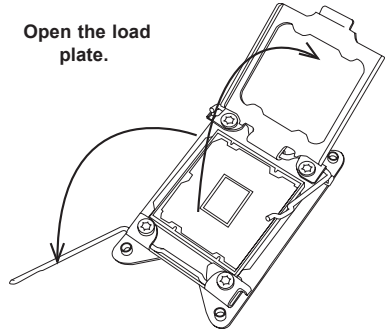

4. Pop the plastic cap marked "Warning" out of the load plate.
5. Holding the CPU carefully above the socket, orient the CPU so that all keys and edges will fit the socket.

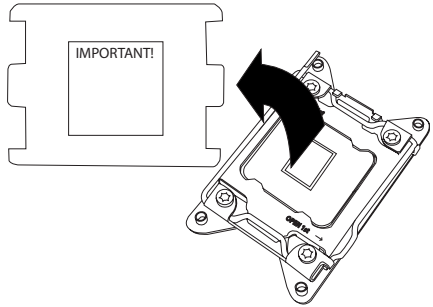

6. Carefully lower the CPU straight down into the socket. Do not move the CPU horizontally, and do not rub the pins of the socket. This may damage the CPU or the socket.

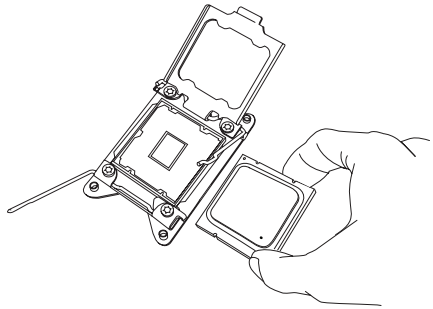

Caution: You can only install the CPU into the socket in one direction. Make sure that the CPU is properly inserted into the socket before closing the load plate. If it does not close properly, do not force it as it may damage your CPU. Instead, open the load plate again and double-check that the CPU is aligned properly.

7. With the "Close 1st" lever fully retracted, gently close the load plate.

**Gently close
the load plate.**

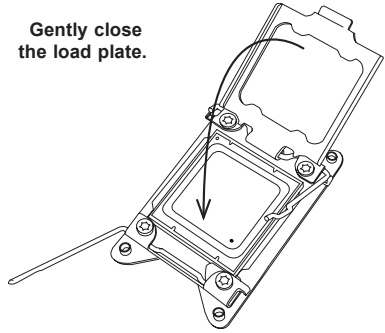

8. Make sure the locking mechanism on the "Close 1st" lever catches the lip of the load plate. Close and lock the "Close 1st" lever.

**Push down and lock the
lever labeled "Close 1st".**

**Engage the lip of
the load plate and
locking portion of
the lever."**

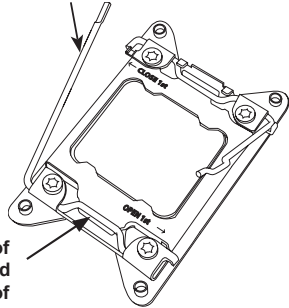

9. Close and lock the "Open 1st" lever.

**Push down and lock the
lever labeled "Open 1st"**

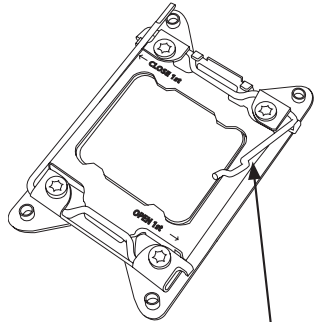

Installing a CPU Heatsink

1. Remove power from the system and unplug the AC power cord from the power supply.
2. Do not apply any thermal grease to the heatsink or the CPU die; the required amount has already been applied.
3. Place the heatsink on top of the CPU so that the four mounting holes are aligned with those on the (preinstalled) heatsink retention mechanism.
4. Screw in two diagonal screws until just snug. Do not fully tighten the screws or you may damage the CPU.
5. Add the two remaining screws then finish the installation by fully tightening all four screws.

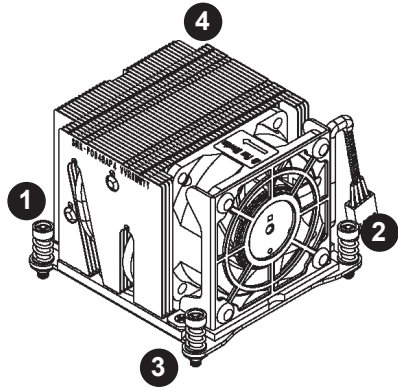

Figure 5-2. SNK-P0048AP4

Removing the Heatsink

Caution: We do not recommend removing the CPU or the heatsink. If you do need to remove the heatsink, please follow the instructions below to prevent damage to the CPU or the CPU socket.

1. Unplug the power cord from the power supply.
2. Unscrew and remove the heatsink screws in the opposite sequence shown in the picture above.
3. Hold the heatsink and gently wriggle it to loosen it from the CPU. (Do not use excessive force!)
4. Once the heatsink is loosened, remove it from the CPU.
5. Clean the surface of the CPU and the heatsink to get rid of the old thermal grease. Reapply the proper amount of thermal grease before re-installing the heatsink.

5-5 Installing Memory

The motherboard supports up to 1.5 TB of Load Reduced (LRDIMM) or 1.5 TB or Registered (RDIMM). Memory modules should be DDR4 ECC 288-pin 2400/2133/1866/1600 MHz in 24 slots. Memory speed is dependent on the CPUs. For best memory performance, install memory modules of the same type and same speed. For the latest CPU/memory updates, refer to the Supermicro website.

Caution: Exercise care installing or removing DIMM modules to avoid damage.

Installing Memory Modules

Insert the desired number of DIMMs into the memory slots, starting with P1-DIMM 1A

1. Push the release tabs outwards on both ends of the DIMM slot to unlock it.
2. Align the key on the DIMM module with the receptacle point on the slot.
3. Use two thumbs together to press on both ends of the module straight down into the slot until the module snaps into place.
4. Press the release tabs to the lock positions to secure the DIMM module into the slot. See Figure 5-2.

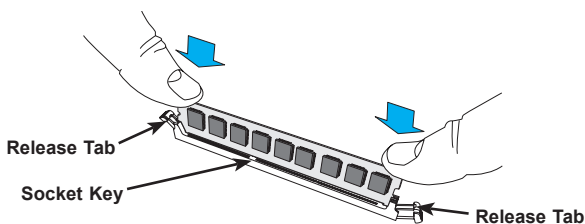

Figure 5-3. Installing DIMM into Slot

Processor/DIMM Population Configurations

- For memory to work properly, follow the tables below for memory installation.
- Install DIMMs in pairs, that is, use an even number of DIMMs.
- All channels in a system will run at the fastest common frequency.

| Processors and their Corresponding Memory Modules | | | | | | | | | | | | |
|---|----------------------------|----|----|----|----|----|----|----|----|----|----|----|
| CPU# | Corresponding DIMM Modules | | | | | | | | | | | |
| CPU 1 P1-DIMM- | A1 | B1 | C1 | D1 | A2 | B2 | C2 | D2 | A3 | B3 | C3 | D3 |
| CPU2 P2-DIMM- | E1 | F1 | G1 | H1 | E2 | F2 | G2 | H2 | E3 | F3 | G3 | H3 |

| Processor and Memory Module Population for Optimal Performance | |
|--|---|
| Number of CPUs+DIMMs | CPU and Memory Population Configuration Table |
| 1 CPU & 2 DIMMs | CPU1 P1-DIMMA1/P1-DIMMB1 |
| 1 CPU & 4 DIMMs | CPU1 P1-DIMMA1/P1-DIMMB1, P1-DIMMC1/P1-DIMMD1 |
| 1 CPU & 5-8 DIMMs | CPU1 P1-DIMMA1/P1-DIMMB1, P1-DIMMC1/P1-DIMMD1 + Any memory pairs in P1-DIMMA2/P1-DIMMB2/P1-DIMMC2/P1-DIMMD2 slots |
| 2 CPUs & 4 DIMMs | CPU1 + CPU2 P1-DIMMA1/P1-DIMMB1, P2-DIMME1/P2-DIMMF1 |
| 2 CPUs & 6 DIMMs | CPU1 + CPU2 P1-DIMMA1/P1-DIMMB1/P1-DIMMC1/P1-DIMMD1, P2-DIMME1/P2-DIMMF1 |
| 2 CPUs & 8 DIMMs | CPU1 + CPU2 P1-DIMMA1/P1-DIMMB1/P1-DIMMC1/P1-DIMMD1, P2-DIMME1/P2-DIMMF1/P2-DIMMG1/P2-DIMMH1 |
| 2 CPUs & 10-14 DIMMs | CPU1/CPU2 P1-DIMMA1/P1-DIMMB1/P1-DIMMC1/P1-DIMMD1, P2-DIMME1/P2-DIMMF1/P2-DIMMG1/P2-DIMMH1 + Any memory pairs in P1, P2 DIMM slots |
| 2 CPUs & 16 DIMMs | CPU1/CPU2 P1-DIMMA1/P1-DIMMB1/P1-DIMMC1/P1-DIMMD1, P2-DIMME1/P2-DIMMF1/P2-DIMMG1/P2-DIMMH1, P1-DIMMA2/P1-DIMMB2/P1-DIMMC2/P1-DIMMD2, P2-DIMME2/P2-DIMMF2/P2-DIMMG2/P2-DIMMH2 |
| 2 CPUs & 16-24 DIMMs | CPU1/CPU2 P1-DIMMA1/P1-DIMMB1/P1-DIMMC1/P1-DIMMD1, P2-DIMME1/P2-DIMMF1/P2-DIMMG1/P2-DIMMH1, P1-DIMMA2/P1-DIMMB2/P1-DIMMC2/P1-DIMMD2, P2-DIMME2/P2-DIMMF2/P2-DIMMG2/P2-DIMMH2, P1-DIMMA3/P1-DIMMB3/P1-DIMMC3/P1-DIMMD3, P2-DIMME3/P2-DIMMF3/P2-DIMMG3/P2-DIMMH3 |

| Populating RDIMM/LRDIMM DDR4 Memory Modules | | | | | | | | | |
|---|-------------------------------|--------------------|------------|--|------------|------------|------------|-------|-------|
| Type | Ranks Per DIMM and Data Width | DIMM Capacity (GB) | | Speed (MT/s); Voltage (V); Slots per Channel (SPC) and DIMMs per Channel (DPC) | | | | | |
| | | | | 3 Slots per Channel | | | | | |
| | | | | 1 DPC | | 2 DPC | | 3 DPC | |
| | | E5-2600 V3 | E5-2600 V4 | E5-2600 V3 | E5-2600 V4 | E5-2600 V3 | E5-2600 V4 | | |
| | | 4 Gb | 8 Gb | 1.2 V | 1.2 V | 1.2 V | 1.2 V | 1.2 V | 1.2 V |
| RDIMM | SRx4 | 8 GB | 16 GB | 2133 | 2400 | 1866 | 2133 | 1600 | 1600 |
| RDIMM | SRx8 | 4 GB | 8 GB | 2133 | 2400 | 1866 | 2133 | 1600 | 1600 |
| RDIMM | DRx8 | 8 GB | 16 GB | 2133 | 2400 | 1866 | 2133 | 1600 | 1600 |
| RDIMM | DRx4 | 16 GB | 32 GB | 2133 | 2400 | 1866 | 2133 | 1600 | 1600 |
| LRDIMM | QRx4 | 32 GB | 64 GB | 2133 | 2400 | 2133 | 2400 | 1600 | 1866 |
| LRDIMM 3DS | 8Rx4 | 64 GB | 128 GB | 2133 | 2400 | 2133 | 2400 | 1600 | 1866 |

5-6 Motherboard Details

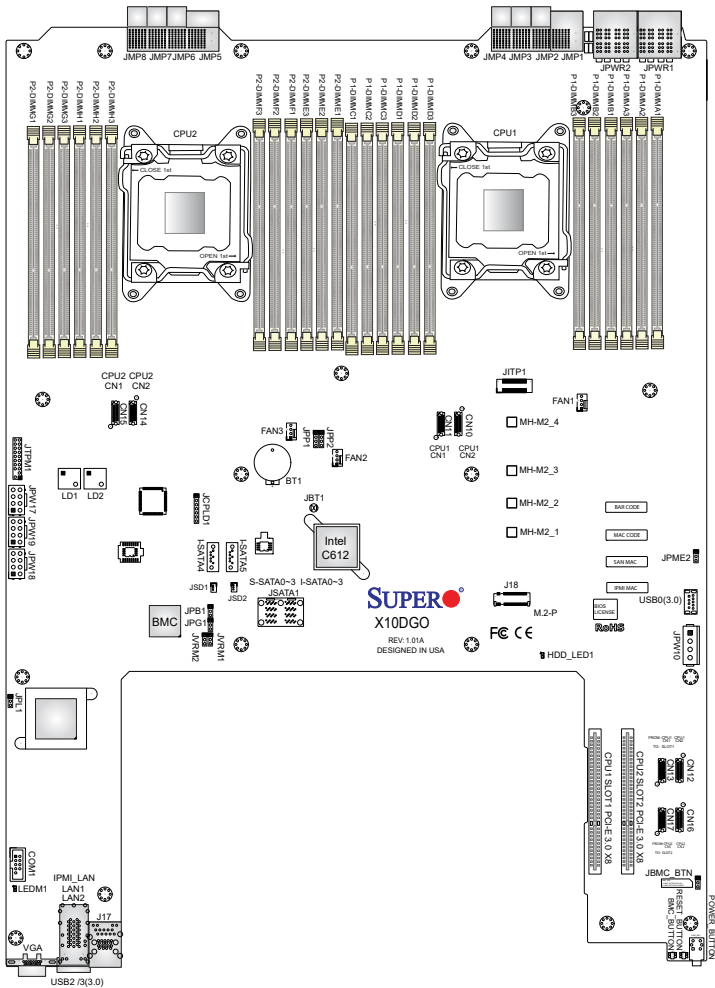

Figure 5-4. X10DGO(-T) Layout

Notes

Jumpers not indicated are for test purposes only.

"■" indicates the location of Pin 1.

The X10DGO-T supports two X540-based 10G LAN ports, the X10DGO supports two I350-based 1G LAN ports.

| Jumper | Description | Default Setting |
|-----------------|---|---------------------------|
| BMC_Button | BMC UID when JBMC_BTN Pins 1-2 are connected BMC Reset when JBMC_BTN Pins 2-3 are connected | BMC UID |
| JBMC_BTN | Select BMC_Button Function: Pins 1-2: BMC_Button works as BMC UID Button Pins 2-3: BMC_Button works as BMC Reset Button | Pins 1-2 |
| JBT1 | Clear CMOS | See Section 5-8 |
| JPB1 | BMC Enable | Pins 1-2 (Enabled) |
| JPG1 | VGA Enable | Pins 1-2 (Enabled) |
| JPL1 | GLAN1/GLAN2 Enable | Pins 1-2 (Enabled) |
| JPME2 | Manufacturer (ME) Mode Select | Pins 1-2 (Normal) |
| JVRM1/ JVRM2 | I2C Bus for VRM | Pins 1-2 (BMC: Normal) |

| Connectors | Description |
|-------------------|--|
| Battery (JBT1) | Onboard CMOS battery |
| CN10-17 | Connects PCI Bus from CPU slot using OCULINK cable |
| COM1 | Serial COM Port |
| FAN1-3 | CPU/System Cooling Fan Headers |
| J18 | M.2 socket 3 for PCIe SSD adapter with M Key or B+M Key |
| JMP1-8 | Connects PCIE bus and controls signals between MB, Midplane, and GPU |
| JPW17-19 | Power for HDD Backplane |
| JPWR1/JPWR2 | Midplane Power Connector |
| JSD1/JSD2 | Power Connector SATA DOM |
| JTPM1 | TPM (Trusted Platform Module)/Port 80 Header |
| (IPMI) LAN | Dedicated IPMI LAN Port |
| LAN1/LAN2 | X540-based 10G Ethernet LAN Ports 1/2 (X10DGO-T); I350-based 1G LAN Ports 1/2 (X10DGO) |
| (I-)SATA0-3 | Intel SATA 3.0 Connectors from Intel PCH SATA controller |
| (I-)SATA4/5 | Intel SATA SuperDOM Connectors from Intel PCH |
| (S-)SATA0-3 | SATA Connectors 3.0 from Intel PCH sSATA controller |
| SLOT1 | PCI-Express 3.0 x8 Slot supported by CPU2 |
| SLOT2 | PCI-Express 3.0 x8 Slot supported by CPU1 |
| USB0 | Internal USB 3.0 Type A Connector |
| USB2/3 | External USB 3.0 Ports |
| VGA | VGA Port |

| LED | Description | State | Status |
|------------|--------------------|-----------------|---------------|
| LEDM1 | BMC Heartbeat LED | Green: Blinking | BMC Normal |

Add-on Module for GPUs

The system includes the X10DGO-SXM add-on board for GPUs.

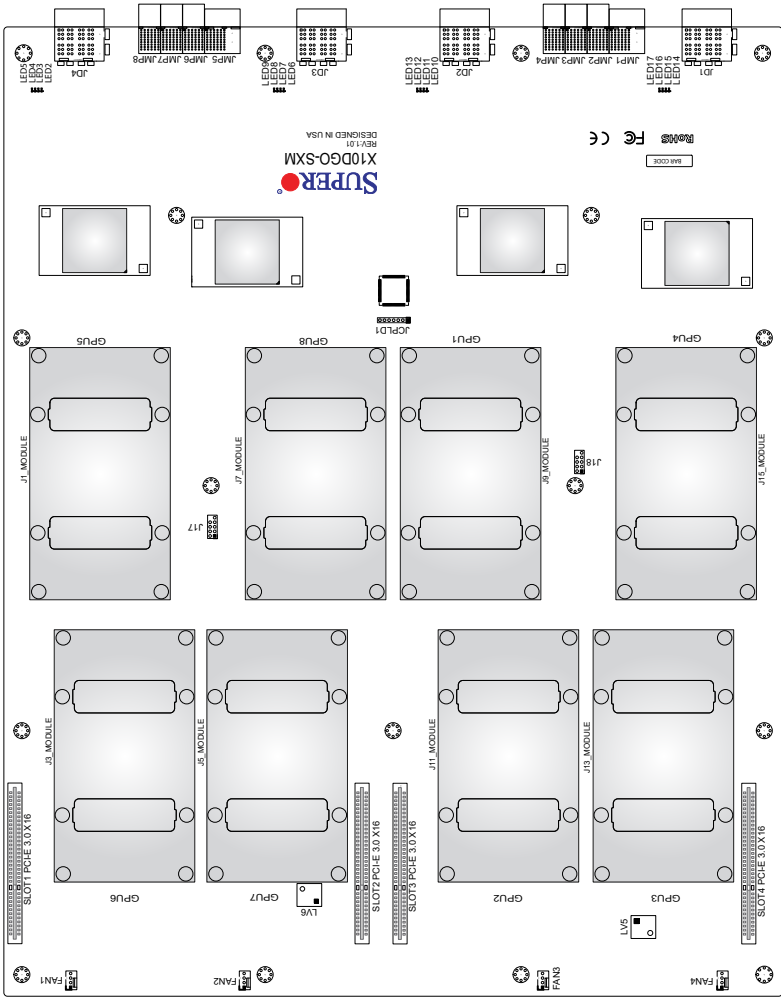

Figure 5-5. X10DGO-SXM Add-on Module

5-7 Connector Definitions

Power Connectors

Main Power

Two 48-pin (JPWR1/2) connectors provide power for the motherboard.

| Main Power Connector (JPW2/JPW1) | |
|----------------------------------|------------|
| Pins | Definition |
| B1[A:F] | 12V |
| B2[A:F] | 12V |
| B3[A:F] | 12V |
| B4[A:F] | 12V |
| A1[A:F] | GND |
| A2[A:F] | GND |
| A3[A:F] | GND |
| A4[A:F] | GND |

Midplane Power

Three 8-pin connectors (JPW17-19) are used to provide power for the HDD midplane.

| Midplane Power Connectors (JPW17-19) | | | |
|--------------------------------------|------------|-------|------------|
| Pin # | Definition | Pin # | Definition |
| 1 | GND | 5 | 12V |
| 2 | GND | 6 | 12V |
| 3 | GND | 7 | 12V |
| 4 | GND | 8 | 12V |

Internal Headers

Fan Headers

The motherboard has three system/CPU fan headers (Fans 1-3). All are 4-pin fan headers that are backward compatible with traditional 3-pin fans. However, fan speed control is available for 4-pin fans only. The fan speeds are controlled by Thermal Management via IPMI 2.0 interface.

| Fan Header Pin Definitions | |
|----------------------------|------------------------|
| Pin# | Definition |
| 1 | Ground |
| 2 | +12V |
| 3 | Tachometer |
| 4 | Pulse Width Modulation |

TPM/Port 80 Header

A Trusted Platform Module/Port 80 header, located at JTPM1, provides TPM support and Port 80 connection. Use this header to enhance system performance and data security.

| TPM/Port 80 Header Pin Definitions | | | |
|---------------------------------------|------------|-------|-------------|
| Pin # | Definition | Pin # | Definition |
| 1 | LCLK | 2 | GND |
| 3 | LFRAME# | 4 | <(KEY)> |
| 5 | LRESET# | 6 | +5V (X) |
| 7 | LAD 3 | 8 | LAD 2 |
| 9 | +3.3V | 10 | LAD1 |
| 11 | LAD0 | 12 | GND |
| 13 | SMB_CLK4 | 14 | SMB_DAT4 |
| 15 | +3V_DUAL | 16 | SERIRQ |
| 17 | GND | 18 | CLKRUN# (X) |
| 19 | LPCPD# | 20 | LDRQ# (X) |

M.2 Slot (J18)

M.2 is formerly known as Next Generation Form Factor (NGFF). The M.2 slot is designed for internal mounting devices. The X10DGO (-T) motherboard deploys an M key only dedicated for SSD devices with the ultimate performance capability for native PCI-E SSD support.

M.2 specifications supported:

- M:2 socket type : Socket 3
- M.2 PCIe bus width : PCIe Gen2 X4 from PCH
- M.2 adapter Key : M Key or B+M Key
- M.2 adapter type : PCI-e SSD only

SATA DOM Power Connectors

Two powered SATADOM (Device-on-Module) connectors are located at JSD1/JSD2 on the motherboard. These connectors are used with Supermicro SuperDOMs, which are yellow SATA devices with power-pins built in, and can be used to provide backward-compatible power support to non-Supermicro SATADOMs that require external power supply without the need for separate power cables.

| SATA DOM PWR Pin Definitions | |
|---------------------------------|---------------|
| Pin# | Definition |
| 1 | +5V Standby |
| 2 | Ground |
| 3 | No Connection |

OCuLink Connectors

These OCuLink connectors (CN10-17) are used to connect the PCIe bus from the CPU to the PCIe slot. OCuLink cables should be connected in pairs according to the diagram below.

PCIe Slot 2 (CPU1): CN10 --> CN12 ; CN11 --> CN13

PCIe Slot 1 (CPU2): CN14 --> CN16 ; CN15 --> CN17

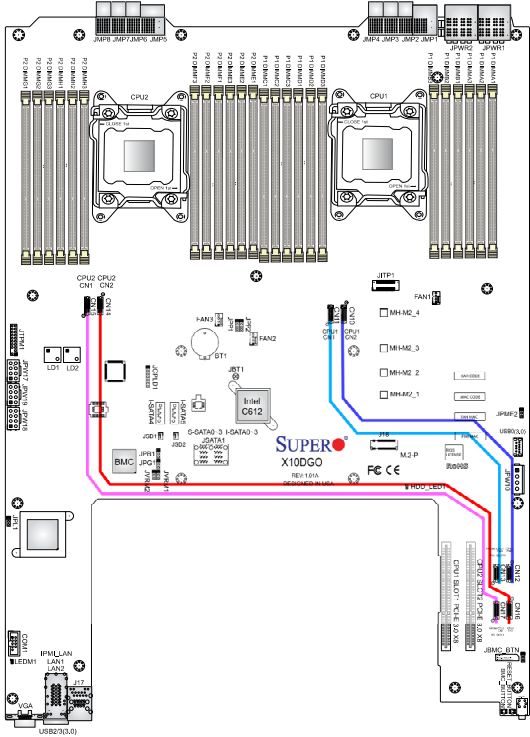

Figure 5-6. OCuLink Connectors

5-8 Jumper Settings

Explanation of Jumpers

To modify the operation of the motherboard, jumpers can be used to choose between optional settings. Jumpers create shorts between two pins to change the function of the connector. Pin 1 is identified with a square solder pad on the printed circuit board. See the motherboard layout pages for jumper locations.

Note: On a two-pin jumper, "Closed" means the jumper is on both pins and "Open" means the jumper is either on only one pin or completely removed.

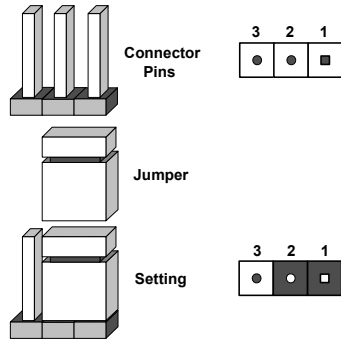

CMOS Clear

JBT1 is used to clear CMOS (which will also clear any passwords). Instead of pins, this jumper consists of contact pads to prevent accidentally clearing the contents of CMOS.

To clear CMOS,

1. First power down the system and unplug the power cord(s).
2. With the power disconnected, short the CMOS pads with a metal object such as a small screwdriver.
3. Remove the screwdriver (or shorting device).
4. Reconnect the power cord(s) and power on the system.

Note: Do not use the PW_ON connector to clear CMOS.

VGA Enable/Disable

JPG1 allows you to enable or disable the VGA port. The default position is on pins 1 and 2 to enable VGA.

| VGA Enable/Disable Jumper Settings | |
|------------------------------------|------------|
| Jumper Setting | Definition |
| Pins 1-2 | Enabled |
| Pins 2-3 | Disabled |

BMC Enable/Disable

Use jumper JPB1 to enable or disable the BMC (Baseboard Management Controller), which supports IPMI 2.0/KVM.

| BMC Enable/Disable Jumper Settings | |
|------------------------------------|------------|
| Both Jumpers | Definition |
| Pins 1-2 | Enabled |
| Pins 2-3 | Disabled |

Manufacturer Mode Select

Close jumper JPME1 to bypass SPI flash security and force the system to operate in Manufacturer Mode, which allows the user to flash the system firmware from a host server to modify system settings.

| ME Mode Select Jumper Settings | |
|--------------------------------|------------------|
| Jumper Setting | Definition |
| 1-2 | Normal (Default) |
| 2-3 | Manufacture Mode |

I²C Bus for VRM

Jumpers JVRM1 and JVRM2 allow the BMC or the PCH to access CPU and memory VRM controllers.

| VRM Controllers Jumper Settings | |
|---------------------------------|---------------|
| Pin # | Definition |
| 1-2 | BMC (Default) |
| 2-3 | PCH |

BMC/UID Button

Jumper JBMC_BTN controls the function of the BMC Button. Connecting pins 1-2 will enable the UID LED. Connecting pins 2-3 will allow the BMC Button to function as the BMC chip reset.

| BMC/UID Button Jumper Settings | |
|--------------------------------|---------------------------------------|
| Pin # | Definition |
| 1-2 | Pressing BMC_BTN will toggle UID LED |
| 2-3 | Pressing BMC_BTN will reset BMC chip. |

5-9 Onboard Indicators

LAN Port LEDs

The Ethernet ports have two LEDs. On each port, one LED indicates activity and the other indicates the link speed of the connection. It may be green, amber or off. See the tables for the colors indicating the link speed.

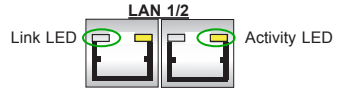

| GLAN Activity Indicator LED | | |
|-----------------------------|----------|------------|
| Color | Status | Definition |
| Yellow | Flashing | Active |

| LAN Link LED (X10DGO) | |
|-----------------------|--------------------------|
| Color | Definition |
| Off | No Connection or 10 Mbps |
| Green | 100 Mbps |
| Amber | 1 Gbps |

| LAN Link LED (For X10DGO-T) | |
|-----------------------------|-------------------------------|
| Color | Definition |
| Off | No Connection, 10 or 100 Mbps |
| Amber | 1 Gbps |
| Green | 10 Gbps |

Dedicated IPMI LAN Port LEDs

A dedicated IPMI LAN port is also located on the I/O backplane. The amber LED on the right indicates activity, while the LED on the left indicates the speed of the connection. See the table at right.

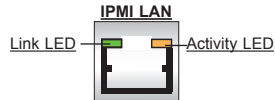

| IPMI LAN Port LEDs | | |
|--------------------|------------------------------|--------------------|
| | Color/State | Definition |
| Link (Left) | Green: Solid Amber: Solid | 100 Mbps 1 Gbps |
| Activity (Right) | Amber: Blinking | Active |

BMC Heartbeat LED

The BMC Heartbeat LED is designated LEDM1. When it is blinking, the BMC (Baseboard Management Controller) is functioning normally.

| BMC Heartbeat Indicator LED Status | |
|------------------------------------|-------------|
| Green: Blinking | BMC: Normal |

5-10 SATA Ports

There are ten SATA 3.0 ports. The four I-SATA ports, I-SATA0-I-SATA3, are supported by the Intel PCH on the motherboard. There four S-SATA connectors, S-SATA0-3, are supported by the Intel SCU chip. I-SATA4/5, colored yellow, are used with Supermicro SuperDOM (Disk-on-Module) connectors with power pins built in, and are compatible with regular SATA HDDs and SATA DOMs that requires external power cables.

5-11 Installing Software

The Supermicro ftp site contains drivers and utilities for your system at <ftp://ftp.supermicro.com>. Some of these must be installed, such as the chipset driver.

After accessing the ftp site, go into the CDR_Images directory and locate the ISO file for your motherboard. Download this file to create a CD/DVD of the drivers and utilities it contains. (You may also use a utility to extract the ISO file if preferred.)

Another option is to go to the Supermicro Website at <http://www.supermicro.com/products/>. Find the product page for your motherboard here, where you may download individual drivers and utilities.

After creating a CD/DVD with the ISO files, insert the disk into the CD/DVD drive on your system and the display shown in Figure 5-8 should appear.

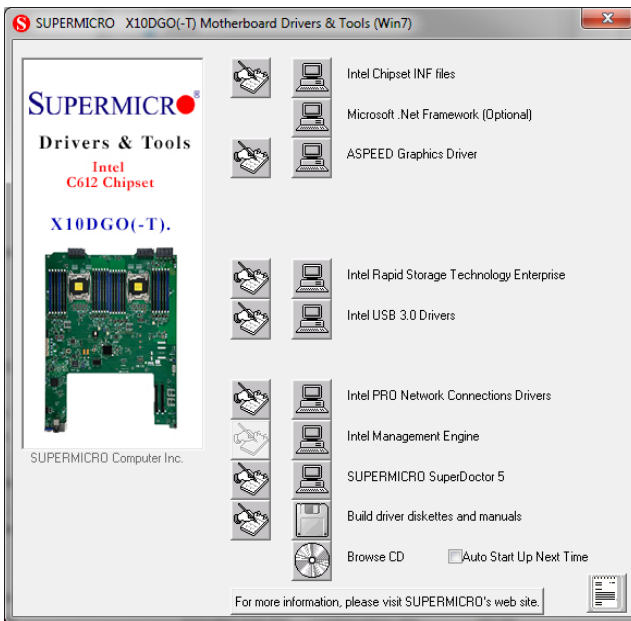

Figure 5-8. Driver Installation Display Screen

Note: Click the icons showing a hand writing on paper to view the readme files for each item. Click the computer icons to the right of these items to install each item (from top to the bottom) one at a time. **After installing each item, you must re-boot the system before moving on to the next item on the list.** The bottom icon with a CD on it allows you to view the entire contents.

SuperDoctor® 5

The Supermicro SuperDoctor 5 is a hardware and operating system services monitoring program that functions in a command-line or web-based interface in Windows and Linux operating systems. The program monitors system health information such as CPU temperature, system voltages, system power consumption, fan speed, and provides alerts via email or Simple Network Management Protocol (SNMP).

SuperDoctor 5 comes in local and remote management versions and can be used with Nagios to maximize your system monitoring needs. With SuperDoctor 5 Management Server (SSM Server), you can remotely control power on/off and reset chassis intrusion for multiple systems with SuperDoctor 5 or IPMI. SD5 Management Server monitors HTTP, FTP, and SMTP services to optimize the efficiency of your operation.

Note: The default User Name and Password for SuperDoctor 5 is ADMIN/ADMIN.



Figure 5-9. SuperDoctor 5 Interface Display Screen (Health Information)

Note: The SuperDoctor 5 program and User's Manual can be downloaded from the Supermicro web site at http://www.supermicro.com/products/nfo/sms_sd5.cfm.

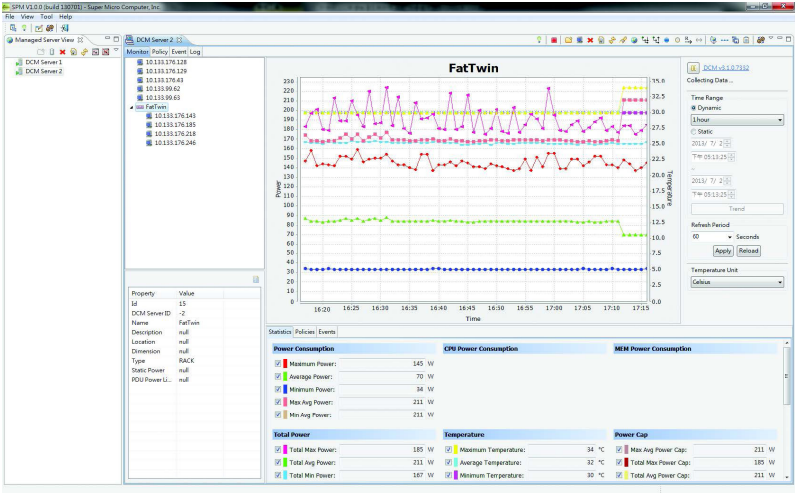

Figure 5-10. SuperDoctor 5 Interface Display Screen (Remote Control)

Note: The SuperDoctor 5 program and User's Manual can be downloaded from the Supermicro web site at http://www.supermicro.com/products/info/sms_sd5.cfm. For Linux, we recommend that you use the SuperDoctor II application instead.

5-12 Onboard Battery

Please handle used batteries carefully. Do not damage the battery in any way; a damaged battery may release hazardous materials into the environment. Do not discard a used battery in the garbage or a public landfill. Please comply with the regulations set up by your local hazardous waste management agency to dispose of your used battery properly.

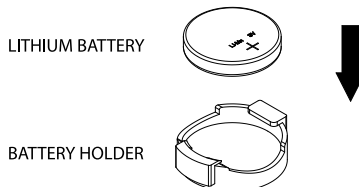

Figure 5-11. Installing the Onboard Battery

Chapter 6

Advanced Chassis Setup

This chapter provides instructions on installing and replacing main system components. To assure compatibility, only use components that match the specifications or part numbers given.

Installation or replacement of most components require that power first be removed from the system.

6-1 Chassis Views

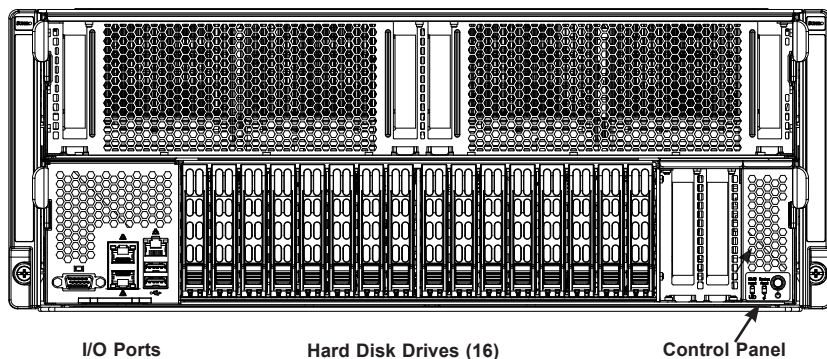

Figure 6-1. Front Chassis View

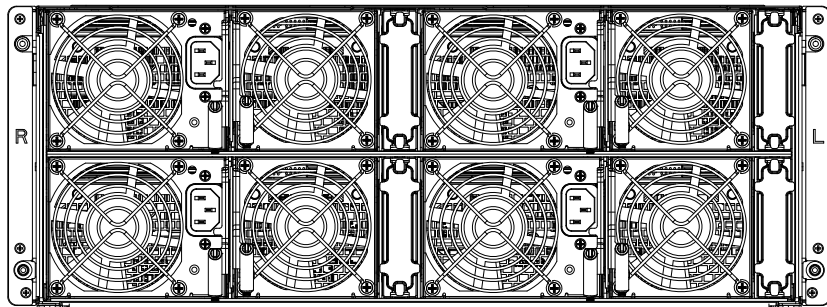

Figure 6-2. Rear Chassis View

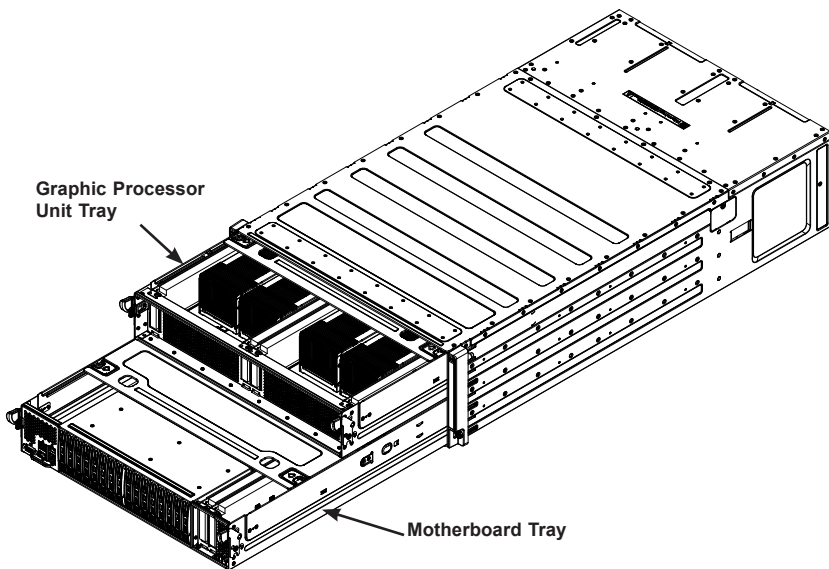

Figure 6-3. Removable Chassis Trays

6-2 Removing Power from the System

Before performing some setup or maintenance tasks, use the following procedure to ensure that power has been removed from the system.

1. Use the operating system to power down the system, following the on-screen prompts.
2. After the system has completely shut-down, carefully grasp the head of the power cord and gently pull it out of the back of the power supply. If your system has dual power supplies, remove the cords from both power supplies.
3. Disconnect the cord from the power strip or wall outlet.

6-3 Installing Storage Drives

The system supports sixteen 2.5" storage drives. If RAID is configured, these drives can be removed or replaced without powering down the system. Eight hybrid connectors on the backplane support NVMe or SAS/SATA drives, and the rest are SAS or SATA.

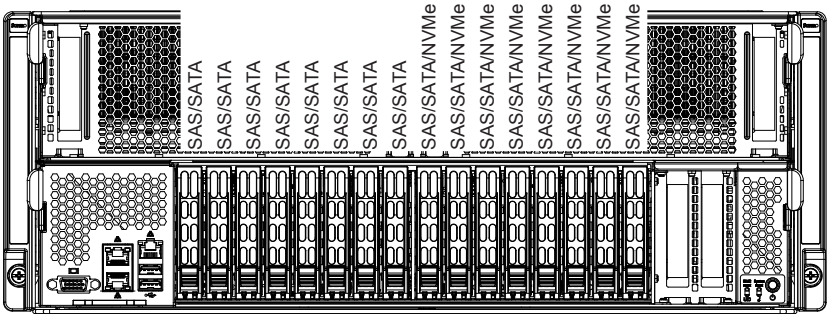

Figure 6-4. Drive Bay Configuration

The NVMe ports provide high-speed, low-latency connections directly from the CPU to NVMe solid state drives (SSDs). This greatly increases SSD throughput and significantly reduces storage device latency by simplifying driver and software requirements resulting from the direct PCIe interface between the CPU and the NVMe SSDs.

Each drive carrier has two status lights, described in Chapter 3 of this manual.

Replacing Drives

The drives are mounted in drive carriers to simplify their installation and removal from the chassis. System power may remain on when removing carriers with drives installed. These carriers also help promote proper airflow for the drive bays. For this reason, even empty carriers without drives installed must remain in the chassis

Removing a Drive and Drive Carrier from the Bay

1. Press the release button on the drive carrier. This extends the drive carrier handle.
2. Use the handle to pull the drive and its carrier out of the chassis.

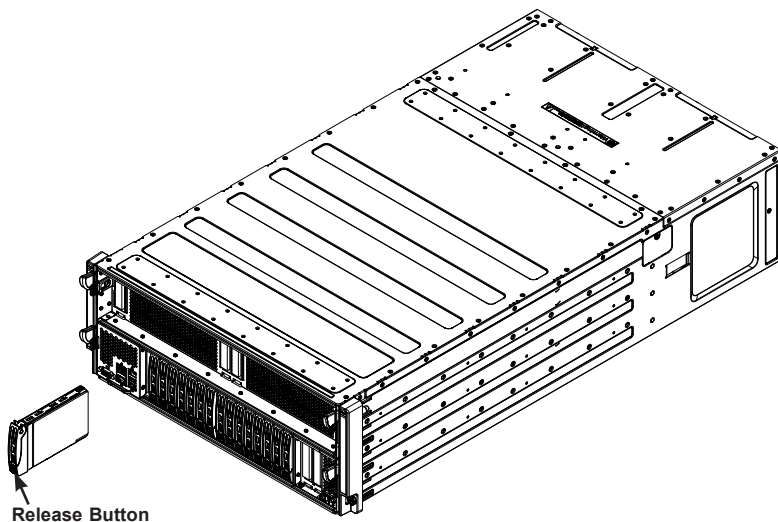
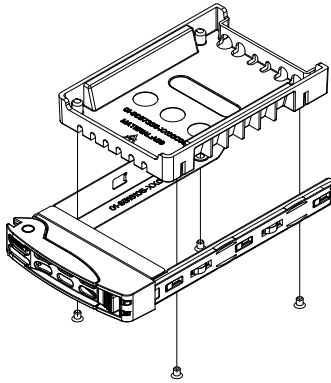

Figure 6-5. Removing a Hard Drive Carrier

Enterprise level storage drives are recommended for use in Supermicro chassis and servers. For information on recommended HDDs, visit the Supermicro Web site at <http://www.supermicro.com/products/nfo/files/storage/SAS-1-CompList-110909.pdf>

Installing a Storage Drive

1. Remove the dummy drive from the carrier by removing the screws.
2. Insert a drive into the carrier with the PCB side facing down and the connector end toward the rear of the carrier. Align the drive in the carrier so that the screw holes line up. Note that there are holes in the carrier marked “SATA” to aid in correct installation.
3. Secure the drive to the carrier with screws.
4. Insert the drive carrier into its bay with the carrier release handle on the top and the release button on the bottom. When the carrier reaches the rear of the bay, the release handle will retract.
5. Push the handle in until it clicks into its locked position.

**Figure 6-6. Removing a Dummy Drive from a Carrier**

6-4 Removing the Chassis Tray Covers

The motherboard tray and the GPU tray each have a cover that can be removed to access internal components.

Removing the Chassis Cover

If working with components such as memory, processors or heatsinks, remove power as described in Section 6-2.

- Slide the release buttons on both sides of the cover toward the middle of the tray and lift the cover.

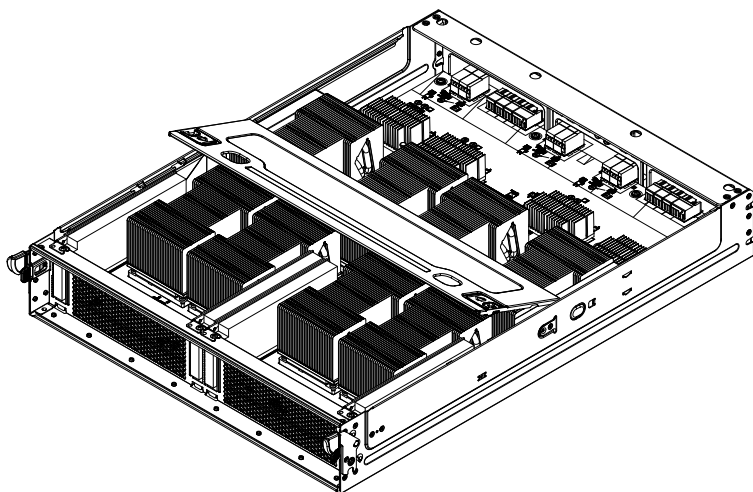

Figure 6-7. Removing a Tray Cover
(GPU tray shown)

Caution: Except for short periods of time, do not operate the server without the cover in place. The cover must be in place to allow proper airflow and prevent overheating.

6-5 Installing Expansion Cards

The X10DGO(-T) system motherboard offers two PCIe expansion card slots. The X10DGO-SXM GPU board offers four additional PCIe slots. All expansion cards must be low profile.

Installing Expansion Cards

1. Power down the system as described in Section 6-2.
2. Slide out the chassis motherboard tray or GPU tray and remove the cover.
3. Remove the screw holding the blank PCI shield in the front of the tray.
4. Insert the expansion card into the board slot, while aligning the expansion card shield with the slot in the front of the tray.
5. Secure expansion card shield to the chassis using the screw.

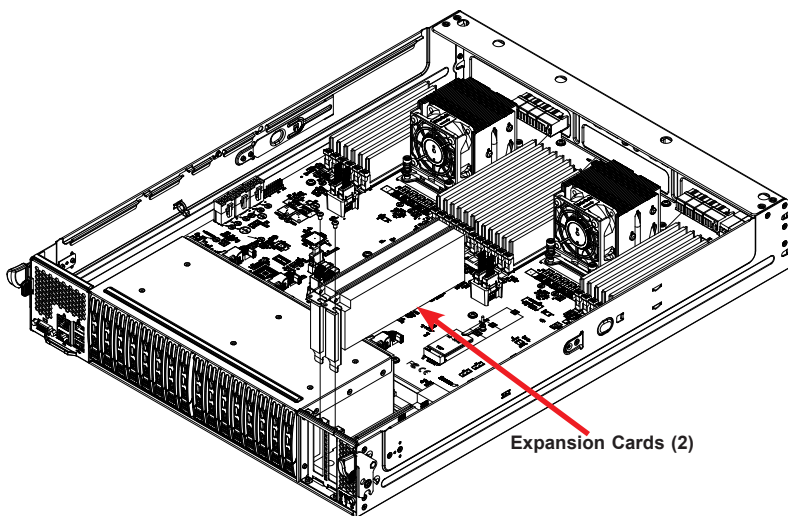

Figure 6-8. Expansion Cards on Motherboard

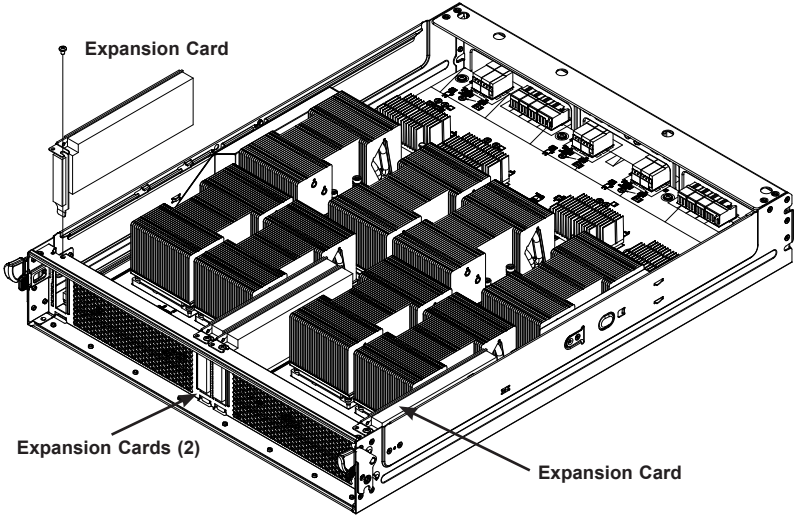

Figure 6-9. Expansion Cards on GPU Board

6-6 Graphic Processor Units

The system supports eight PASCAL SXM2 P100 GPUs installed on the X10DGO-SXM add-on module mounted on the GPU chassis tray and connected to the motherboard by the midplane.

GPU Mapping

The GPU numbering shows differently, depending on the interface. There is the silkscreen label on the board, the GPU number in IPMI, and the number referenced in the operating system. See the relationships in the table below.

| GPU Mapping Table | | | | | | | | |
|-------------------|---------|---------|---------|---------|---------|---------|---------|---------|
| Label | GPU0 | GPU1 | GPU2 | GPU3 | GPU4 | GPU5 | GPU6 | GPU7 |
| IPMI | GPU1 | GPU2 | GPU3 | GPU4 | GPU5 | GPU6 | GPU7 | GPU8 |
| OS | GPU2 | GPU3 | GPU0 | GPU1 | GPU6 | GPU7 | GPU4 | GPU5 |
| Bus No. | 09:00.0 | 0A:00.0 | 04:00.0 | 05:00.0 | 89:00.0 | 8A:00.0 | 85:00.0 | 86:00.0 |

The GPU connections are shown below.

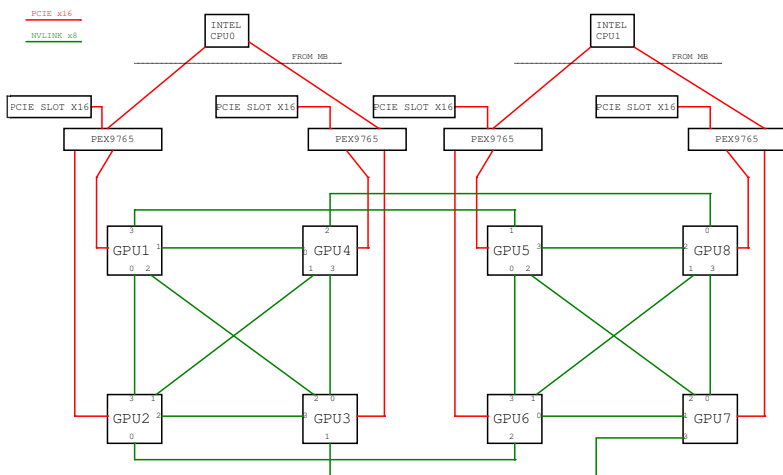

Figure 6-10. GPU Connections
(GPU numbering as in IPMI)

Installing a GPU

1. Remove the GPU chassis tray from the main chassis, and remove the cover.
2. Remove all the plastic socket covers on both the GPU and the add-on module.
3. Position the GPU on the bracket on the add-on module board. Note that the GPU has two asymmetrical guide pins that line up with holes in the add-on board. They allow only the correct orientation of the GPU.
4. Secure the GPU with eight screws. Screw the four inside screws first in a diagonal pattern, then the four outside screws in a diagonal pattern. Be careful not to damage the surrounding elements.
5. From the thermal pads on the heatsink, remove the protective blue paper.
6. Position the heatsink on the GPU so that the heatsink part number faces the right side of the chassis tray (right side when viewed from the front of the tray).
7. Secure the heatsink with four screws, tightening in a diagonal pattern.

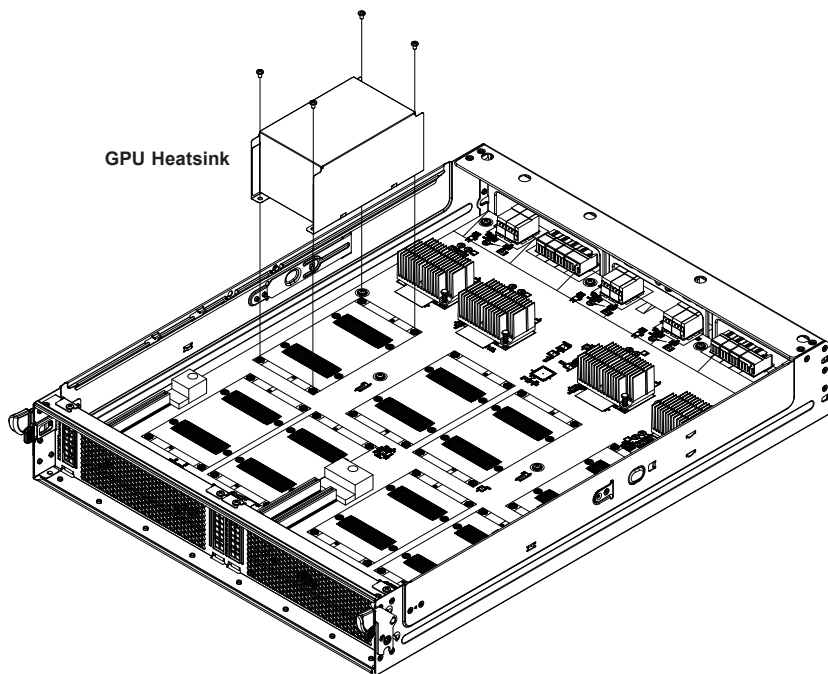

Figure 6-11. Installing a GPU Heatsink

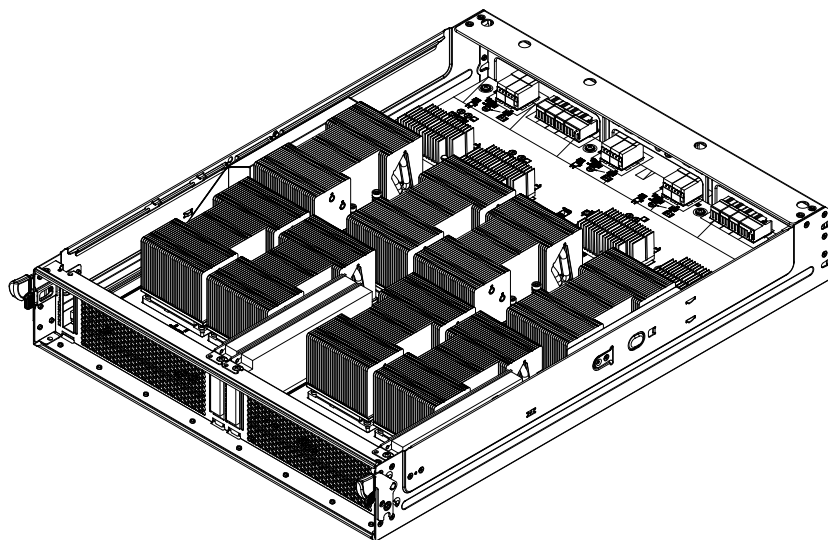

Figure 6-12. GPU Heatsinks Installed

6-7 Installing the Air Shroud

Air shrouds concentrate airflow to maximize fan efficiency.

Installing the GPU Air Shroud

1. Remove the GPU tray using the levers on each side of the tray front..
2. Noting the front and rear sides of the air shroud, insert the sides of the air shroud between the chassis and GPU1 and GPU8. Adjust the air shroud so that front edge is flush with the fan bracket.
3. Secure each shroud with two screws.

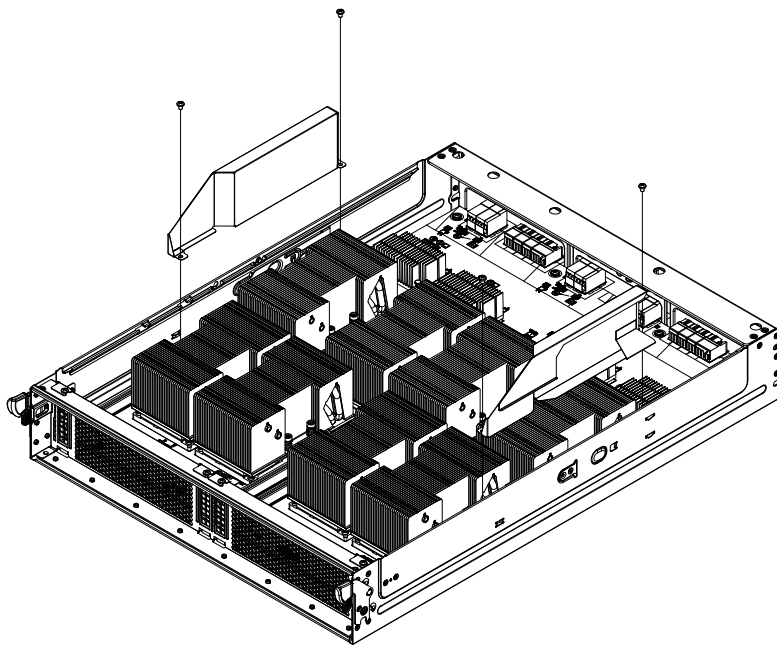

Figure 6-13. GPU Air Shroud Placement

6-8 Replacing Fans

The chassis contains eight 9-cm exhaust fans that provide cooling for the system. There is no need to power down the system when switching fans.

Changing a System Fan

1. Determine which fan has failed using IPMI or observation.
2. If the fan unit includes an AC power plug, remove the power cord.
3. Lift the locking lever and pull the fan from the housing.
4. Push the new fan into the housing until it clicks into place.

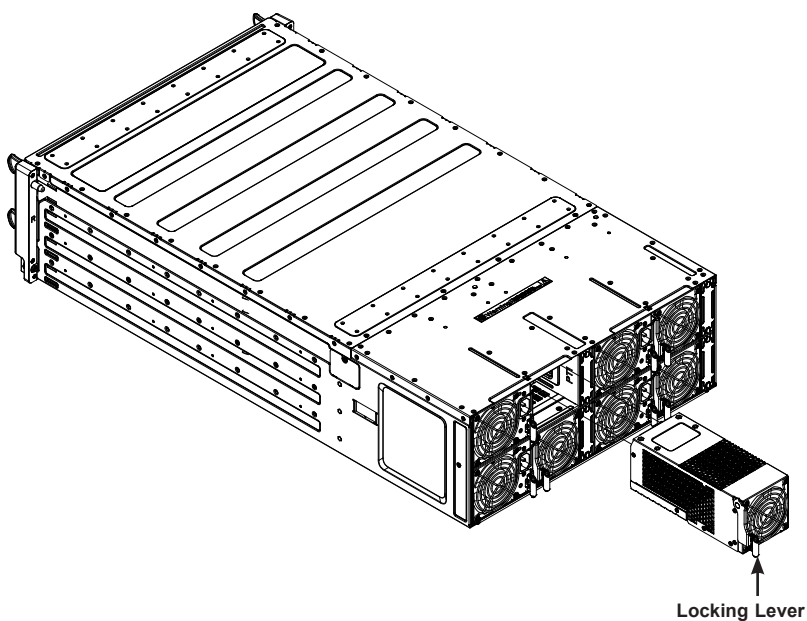

Figure 6-14. Replacing a System Fan

6-9 Power Supply

The system includes four hot-plug power supplies in modules combined with system fans. The power supplies automatically sense the input voltage between 100v to 240v, and operate at that voltage. Note that different input voltages will result in different maximum power output levels.

In the event of a power supply failure, the remaining power modules will automatically take over. The failed power module can be replaced without powering-down the system. Replace with the same model. Replacement modules can be ordered directly from Supermicro.

An amber light on the power supply is illuminated when the power is switched off. A green light indicates that the power supply is operating.

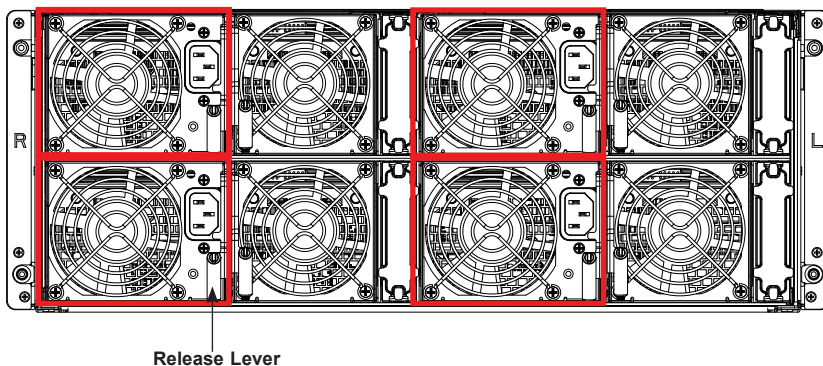

Figure 6-15. Power Supply Modules (4)
(outlined in red)

Replacing the Power Supply

1. Unplug the AC power cord from the failed power supply module at the rear of the chassis.
2. Lift the locking release lever and pull the power/fan module from the housing.
3. Push the new power supply module into the bay until it clicks into the locked position.
4. Plug the AC power cord back into the power supply module.

Chapter 7

BIOS

7-1 Introduction

This chapter describes the AMI BIOS setup utility for the X10DGO(-T). It also provides the instructions on how to navigate the AMI BIOS setup utility screens. The AMI ROM BIOS is stored in a Flash EEPROM and can be easily updated.

Starting BIOS Setup Utility

To enter the AMI BIOS setup utility screens, press the key while the system is booting up.

Note: In most cases, the key is used to invoke the AMI BIOS setup screen. There are a few cases when other keys are used, such as <F3>, <F4>, etc.

Each main BIOS menu option is described in this manual. The Main BIOS setup menu screen has two main frames. The left frame displays all the options that can be configured. Grayed-out options cannot be configured. Options in blue can be configured by the user. The right frame displays the key legend. Above the key legend is an area reserved for informational text. When an option is selected in the left frame, it is highlighted in white. Often informational text will accompany it.

Note: The AMI BIOS has default informational messages built in. The manufacturer retains the option to include, omit, or change any of these informational messages.

The AMI BIOS setup utility uses a key-based navigation system called "hot keys." Most of the AMI BIOS setup utility "hot keys" can be used at any time during setup navigation. These keys include <F3>, <F4>, <Enter>, <ESC>, arrow keys, etc.

Note 1: Options printed in **Bold** are default settings.

Note 2: <F3> is used to load optimal default settings. <F4> is used to save the settings and exit the setup utility.

How To Change the Configuration Data

The configuration data that determines the system parameters may be changed by entering the AMI BIOS setup utility. This setup utility can be accessed by pressing <Delete> at the appropriate time during system boot.

Note: For AMI UEFI BIOS Recovery, please refer to the UEFI BIOS Recovery User Guide posted @ <http://www.supermicro.com/support/manuals/>.

Starting the Setup Utility

Normally, the only visible Power-On Self-Test (POST) routine is the memory test. As the memory is being tested, press the <Delete> key to enter the main menu of the AMI BIOS setup utility. From the main menu, you can access the other setup screens. An AMI BIOS identification string is displayed at the left bottom corner of the screen below the copyright message.

Caution: Do not upgrade the BIOS unless your system has a BIOS-related issue. Flashing the wrong BIOS can cause irreparable damage to the system. In no event shall the manufacturer be liable for direct, indirect, special, incidental, or consequential damage arising from a BIOS update. If you have to update the BIOS, do not shut down or reset the system while the BIOS is being updated to avoid possible boot failure.

7-2 Main Setup

When you first enter the AMI BIOS setup utility, you will enter the Main setup screen. You can always return to the Main setup screen by selecting the Main tab on the top of the screen. The Main BIOS setup screen is shown below.

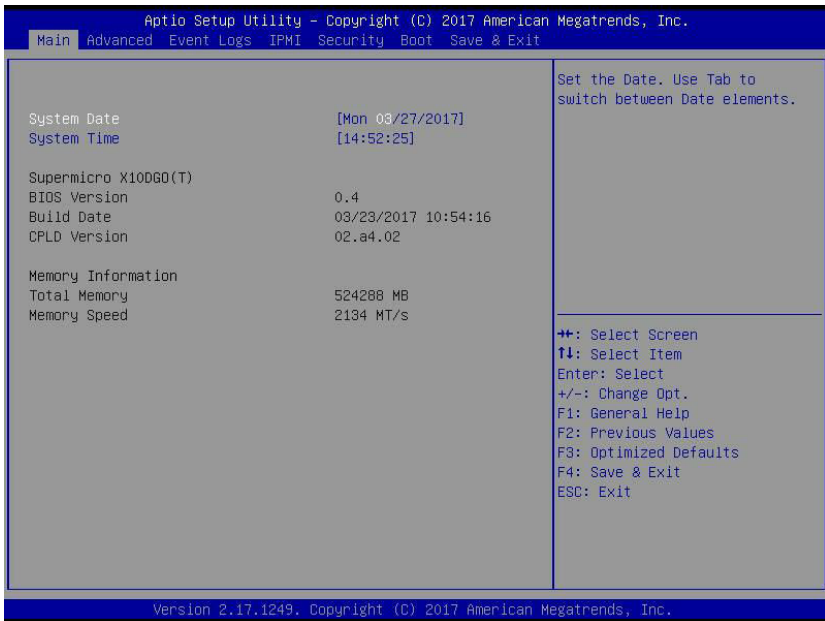

The AMI BIOS Main menu displays the following information:

System Date

Use this item to change the system date. Press the <Tab> key to move between fields. Enter new values through the keyboard and press <Enter>. The date must be entered in MM/DD/YYYY format.

System Time

Use this item to change the system time. Press the <Tab> key to move between fields. Enter new values through the keyboard and press <Enter>. The time is entered in HH:MM:SS format. The time is in the 24-hour format. For example, 5:30 P.M. appears as 17:30:00.

Supermicro X10DGO(-T)

BIOS Version: This item displays the version of the BIOS ROM used in the system.

Build Date: This item displays the date when the version of the BIOS ROM used in the system was built.

Memory Information

Total Memory: This item displays the total size of memory available in the system.

Memory Speed: This item displays the default speed of the memory modules installed in the system.

7-3 Advanced Setup Configurations

Use the arrow keys to select the Advanced tab and press <Enter> to access the submenu items.

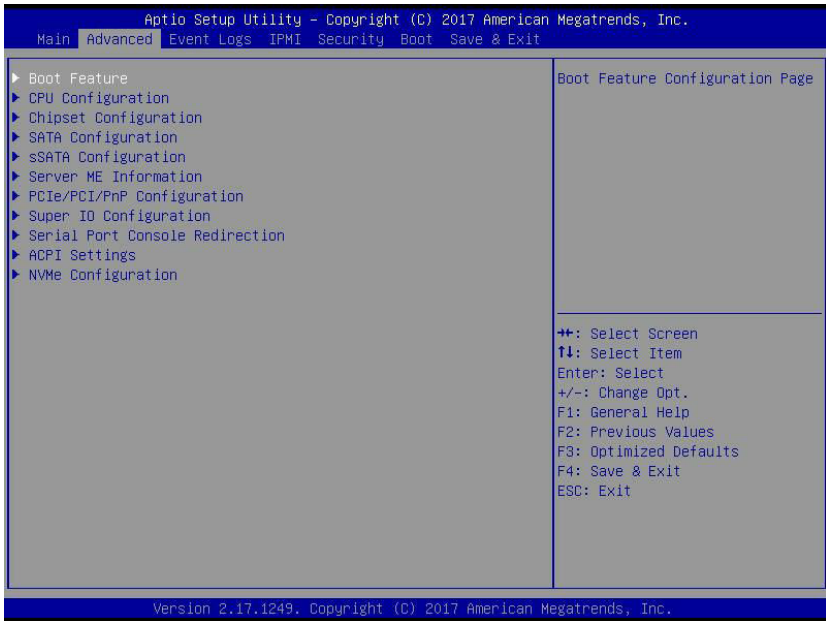

Caution: Take caution when changing the Advanced settings. An incorrect value, a very high DRAM frequency, or an incorrect DRAM timing setting may make the system unstable. If this occurs, revert to the manufacture default settings.

▶ Boot Feature

Quiet Boot

This feature selects the bootup screen display between POST messages and the OEM logo. Select Disabled to display the POST messages. Select Enabled to display the OEM logo instead of the normal POST messages. The options are Enabled and **Disabled**.

AddOn ROM Display Mode

This item sets the display mode for the Option ROM. Select Keep Current to use the current AddOn ROM Display setting. Select Force BIOS to use the Option ROM display mode set by the system BIOS. The options are **Force BIOS** and Keep Current.

Bootup Num-Lock State

This feature sets the Power-on state for the Numlock key. The options are Off and **On**.

Wait For 'F1' If Error

Select Enabled to force the system to wait until the 'F1' key is pressed if an error occurs. The options are Disabled and **Enabled**.

Interrupt 19 Capture

Interrupt 19 is the software interrupt that handles the boot disk function. When this item is set to Enabled, the ROM BIOS of the host adaptors will "capture" Interrupt 19 at bootup and allow the drives that are attached to these host adaptors to function as bootable disks. If this item is set to Disabled, the ROM BIOS of the host adaptors will not capture Interrupt 19, and the drives attached to these adaptors will not function as bootable devices. The options are **Immediate** and Postponed.

Retry Boot

Select Enabled to force the system to reboot when system fails to boot. The options are **Disabled** and Enabled.

Power Configuration

Watch Dog Function

If enabled, the Watch Dog timer will allow the system to reboot when it is inactive for more than 5 minutes. The options are Enabled and **Disabled**.

Power Button Function

If this feature is set to Instant_Off, the system will power off immediately as soon as the user presses the power button. If this feature is set to 4_Second_Override, the system will power off when the user presses the power button for 4 seconds or longer. The options are **Instant_Off** and 4_Second_Override.

Restore on AC Power Loss

This feature sets the power state after a power outage. Select Power-Off for the system power to remain off after a power loss. Select Power-On for the system power to be turned on after a power loss. Select Last State to allow the system to resume its last state before a power loss. The options are Power-On, Stay-Off and **Last State**.

► CPU Configuration

This submenu displays the information of the CPU as detected by the BIOS. It also allows the user to configuration CPU settings.

Socket 0 CPU Information/Socket 1 CPU Information

This submenu displays the following information regarding the CPU installed in Socket 1 and (or) Socket 2 as detected by the BIOS.

- Processor Socket
- Processor ID
- Processor Frequency
- Processor Maximum Ratio
- Processor Minimum Ratio
- Microcode Revision
- L1 Cache RAM
- L2 Cache RAM
- L3 Cache RAM
- CPU0 Version
- CPU1 Version

Clock Spread Spectrum

Select Enable to enable Clock Spectrum support, which will allow the BIOS to monitor and attempt to reduce the level of Electromagnetic Interference caused by the components whenever needed. The options are **Disabled** and Enabled.

Hyper-Threading (ALL)

Select Enabled to support Intel Hyper-threading Technology to enhance CPU performance. The options are **Enabled** and Disabled.

Cores Enabled

Set a numeric value to enable the number of cores. (Please refer to Intel's website for more information.) Enter **0** to enable all cores.

Execute Disable Bit (Available if supported by the OS & the CPU)

Select Enabled to enable the Execute-Disable Bit which will allow the processor to designate areas in the system memory where an application code can execute and where it cannot, thus preventing a worm or a virus from flooding illegal codes to overwhelm the processor or damage the system during an attack. The default is **Enabled**. (Refer to Intel and Microsoft Web sites for more information.)

PPIN Control

Select Enable to unlock the PPIN control. The options are **Enabled** and Disabled.

Hardware Prefetcher (Available when supported by the CPU)

If set to Enabled, the hardware prefetcher will prefetch streams of data and instructions from the main memory to the L2 cache to improve CPU performance. The options are Disabled and **Enabled**.

Adjacent Cache Line Prefetch (Available when supported by the CPU)

The CPU prefetches the cache line for 64 bytes if this feature is set to Disabled. The CPU prefetches both cache lines for 128 bytes as comprised if this feature is set to **Enabled**.

DCU Streamer Prefetcher (Available when supported by the CPU)

Select Enabled to enable the DCU (Data Cache Unit) Streamer Prefetcher which will stream and prefetch data and send it to the Level 1 data cache to improve data processing and system performance. The options are Disabled and **Enabled**.

DCU IP Prefetcher (Available when supported by the CPU)

Select Enabled for DCU (Data Cache Unit) IP Prefetcher support, which will prefetch IP addresses to improve network connectivity and system performance. The options are Disabled and **Enabled**.

Direct Cache Access (DCA Support)

Select Enabled to use Intel's DCA (Direct Cache Access) Technology to improve data transfer efficiency. The options are **Enabled** and Disabled.

X2APIC

Select Enable to activate APIC (Advanced Programmable Interrupt Controller) support. The options are **Enabled** and Disabled.

AES-NI

Select Enable to use the Intel Advanced Encryption Standard (AES) New Instructions (NI) to ensure data security. The options are **Enabled** and Disabled.

Intel Virtualization Technology (Available when supported by the CPU)

Select Enabled to support Intel Virtualization Technology, which will allow one platform to run multiple operating systems and applications in independent partitions, creating multiple "virtual" systems in one physical computer. The options are **Enabled** and Disabled.

Note: If a change is made to this setting, you will need to reboot the system for the change to take effect. Refer to Intel's website for detailed information.

► Advanced Power Management Configuration

This section is used to configure the following CPU Power Management settings.

Power Technology

Select Energy Efficiency to support power-saving mode. Select Custom to customize system power settings. Select Disabled to disable power-saving settings. The options are Disable, **Energy Efficiency**, and Custom.

If the above is set to 'Custom' the following options are displayed:

► CPU P State Control

EIST (P-States)

EIST (Enhanced Intel SpeedStep Technology) allows the system to automatically adjust processor voltage and core frequency to reduce power consumption and heat dissipation. The options are Disabled, and **Enabled**.

Turbo Mode (Available when Intel EIST Technology is enabled)

Select Enabled to use the Turbo Mode to boost system performance. The options are **Enabled** and Disabled.

P-State Coordination

This feature allows the user to change the P-State (Power-Performance State) coordination type. P-State is also known as "SpeedStep" for Intel processors. Select HW_ALL to change the P-State coordination type for hardware components only. Select SW_ALL to change the P-State coordination type for all software installed in the system. Select SW_ANY to change the P-State coordination

type for a software program in the system. The options are **HW_All**, **SW_ALL**, and **SW_ANY**.

► CPU HWPM State Control

Enable CPU HWPM

This setting allows the user to select between OS and hardware-controlled P-states. Selecting Native Mode allows the OS to choose a P-state. Selecting Out of Band Mode allows the hardware to autonomously choose a P-state without OS guidance. Selecting Native Mode with No Legacy Support functions as Native Mode with no support for older hardware.

Enable CPU Autonomous Cstate

Enabling this setting allows the hardware to autonomously choose to enter a C-state based on power consumption and clock speed.

► CPU C State Control

Package C State limit

This feature allows the user to set the limit on the C-State package register. The options are C0/C1 State, C2 State, C6 (Non Retention) State, and **C6 (Retention) State**.

CPU C3 Report

Select Enabled to allow the BIOS to report the CPU C3 State (ACPI C2) to the operating system. During the CPU C3 State, the CPU clock generator is turned off. The options are Enabled and **Disabled**.

CPU C6 Report

Select Enabled to allow the BIOS to report the CPU C6 State (ACPI C3) to the operating system. During the CPU C6 State, the power to all cache is turned off. The options are **Enabled** and Disabled.

Enhanced Halt State (C1E)

Select Enabled to use Enhanced Halt-State technology, which will significantly reduce the CPU's power consumption by reducing the CPU's clock cycle and voltage during a Halt-state. The options are Disable and **Enable**.

▶ CPU T State Control

ACPI (Advanced Configuration Power Interface) T-States

Select Enable to support CPU throttling by the operating system to reduce power consumption. The options are **Enable** and **Disable**.

▶ Chipset Configuration

▶ North Bridge

This feature allows the user to configure the following North Bridge settings.

▶ IIO Configuration

EV DFX (Device Function On-Hide) Feature

When this feature is set to Enable, the EV_DFX Lock Bits that are located on a processor will always remain clear during electric tuning. The options are **Disable** and **Enable**.

▶ IIO1 Configuration / IIO2 Configuration

IIO1 PORT 1A Link Speed

This item configures the link speed of a PCI-E port specified by the user. The options are Gen 1 (Generation 1) (2.5 GT/s), Gen 2 (Generation 2) (5 GT/s) and **Gen 3 (Generation 3) (8 GT/s)**.

IIO1 PORT 2A Link Speed

Use this item to configure the link speed of a PCI-E port specified by the user. The options are Gen 1 (Generation 1) (2.5 GT/s), Gen 2 (Generation 2) (5 GT/s) and **Gen 3 (Generation 3) (8 GT/s)**.

IIO1 PORT 3A Link Speed

Use this item to configure the link speed of a PCI-E port specified by the user. The options are Gen 1 (Generation 1) (2.5 GT/s), Gen 2 (Generation 2) (5 GT/s) and **Gen 3 (Generation 3) (8 GT/s)**.

► IIO2 Configuration

IIO2 Port 1A Link Speed

Select GEN1 to enable PCI-Exp Generation 1 support for Port 1A. Select GEN2 to enable PCI-Exp Generation 2 support for Port 1A. Select GEN3 to enable PCI-Exp Generation 3 support for Port 1A. The options are GEN1, GEN2, and **GEN3**.

IIO2 Port 2A Link Speed

Select GEN1 to enable PCI-Exp Generation 1 support for Port 2A. Select GEN2 to enable PCI-Exp Generation 2 support for Port 2A. Select GEN3 to enable PCI-Exp Generation 3 support for Port 2A. The options are GEN1, GEN2, and **GEN3**.

IIO2 Port 3A Link Speed

Select GEN1 to enable PCI-Exp Generation 1 support for Port 3A. Select GEN2 to enable PCI-Exp Generation 2 support for Port 3A. Select GEN3 to enable PCI-Exp Generation 3 support for Port 3A. The options are GEN1, GEN2, and **GEN3**.

► IOAT (Intel® IO Acceleration) Configuration

Enable IOAT

Select Enable to enable Intel I/OAT (I/O Acceleration Technology) support, which significantly reduces CPU overhead by leveraging CPU architectural improvements and freeing the system resource for other tasks. The options are **Enable** and Disable.

No Snoop

Select Enable to support no-snoop mode for each CB device. The options are **Disable** and Enable.

Relaxed Ordering

Select Enable to enable Relaxed Ordering support which will allow certain transactions to violate the strict-ordering rules of PCI bus for a transaction to be completed prior to other transactions that have already been enqueued. The options are **Disable** and Enable.

► Intel VT for Directed I/O (VT-d)

Intel VT for Directed I/O (VT-d)

Select Enable to use Intel Virtualization Technology support for Direct I/O VT-d support by reporting the I/O device assignments to the VMM (Virtual Machine Monitor) through the DMAR ACPI Tables. This feature offers fully-protected I/O resource sharing across Intel platforms, providing greater reliability, security and availability in networking and data-sharing. The options are **Enable** and Disable.

Interrupt Remapping

Select Enable for Interrupt Remapping support to enhance system performance. The options are **Enable** and Disable.

► QPI (Quick Path Interconnect) Configuration

QPI Status

The following information will display:

- Number of CPU
- Number of IIO
- Current QPI Link Speed
- Current QPI Link Frequency
- QPI Global MMIO Low Base/Limit
- QPI Global MMIO High Base/Limit
- QPI PCIe Configuration Base/Size

Link Frequency Select

Use this item to select the CPU Frequency. The options are 6.4 GB/s, 8.0 GB/s, 9.6 GB/s, **Auto**, Auto Limited.

Link L0p Enable

Select Enable for Link L0p support. The options are **Enable** and Disable.

Link L1 Enable

Select Enable for Link L1 support. The options are **Enable** and Disable.

COD Enable (Available when the OS and the CPU support this feature)

Select Enabled for Cluster-On-Die support to enhance system performance in cloud computing. The options are Enable, Disable, and **Auto**.

Early Snoop (Available when the OS and the CPU support this feature)

Select Enabled for Early Snoop support to enhance system performance. The options are Enable, Disable, and **Auto**.

Home Dir Snoop with IVT- Style OSB

Enable/Disable Home Directory Snoop mode to configure Opportunistic Snoop Broadcast (OSB) for advanced operations. Enable this setting for workloads with high cache transfers. The effect depends on applications in use.

Isoc Mode

Select Enabled for Isochronous support to meet QoS (Quality of Service) requirements. This feature is especially important for Virtualization Technology. The options are Enable and **Disable**.

► Memory Configuration**Enforce POR**

Select Enable to enforce POR restrictions on DDR4 frequency and voltage programming. The options are **Enabled** and Disabled.

Memory Frequency

Use this feature to set the maximum memory frequency for onboard memory modules. The options are **Auto**, 1333, 1400, 1600, 1800, 1867, 2000, 2133, 2200, 2400, 2600, 2667, and Reserved (Do not select Reserved).

Data Scrambling

Select Enabled to enable data scrambling to enhance system performance and data integrity. The options are **Auto**, Disabled and Enabled.

Enable ADR

Select Enable for ADR (Automatic Diagnostic Repository) support to enhance memory performance. The options are Disable and **Enable**.

Erase-Arm NVDIMMs

This function arms the NVDIMMs to save operations in the event of a power loss.

Restore NVDIMMs

This feature allows NVDIMM data to be restored upon power-up.

Interleave NVDIMMs

This setting allows the user to decide if NVDIMMs are interleaved together or not.

DRAM RAPL Baseline

Use this feature to set the run-time power-limit baseline for DRAM modules. The options are Disable, DRAM RAPL Mode 0, and **DRAM RAPL Mode 1**.

ACPI Shutdown Trigger ADR

Enabling this setting will allow the BIOS to send an ADR (Automatic Diagnostic Repository) trigger command to the BMC during a graceful shutdown. If the BMC is out of order, the system will freeze and will need to be powered down manually.

Set Throttling Mode

Throttling improves reliability and reduces power consumption in the processor via automatic voltage control during processor idle states. The options are Disabled and **CLTT** (Closed Loop Thermal Throttling).

Socket Interleave Below 4GB

Select Enabled for the memory above the 4G Address space to be split between two sockets. The options are Enable and **Disable**.

A7 Mode

Select Enabled to support the A7 (Addressing) mode to improve memory performance. The options are **Enable** and Disable.

► DIMM Information

This item displays the status of a DIMM module specified by the user.

- P1-DIMMA1 - P1-DIMMD1
- P2-DIMME1 - P2-DIMMH1

► Memory RAS (Reliability_Availability_Serviceability) Configuration

Use this submenu to configure the following Memory RAS settings.

RAS Mode

When Disable is selected, RAS is not supported. When Mirror is selected, the motherboard maintains two identical copies of all data in memory for data backup.

When Lockstep is selected, the motherboard uses two areas of memory to run the same set of operations in parallel to boost performance. The options are **Disable**, Mirror, and Lockstep Mode.

Memory Rank Sparing

Select Enable to enable memory-sparing support for memory ranks to improve memory performance. The options are **Disabled** and Enabled.

Patrol Scrub

Patrol Scrubbing is a process that allows the CPU to correct correctable memory errors detected on a memory module and send the correction to the requestor (the original source). When this item is set to Enabled, the IO hub will read and write back one cache line every 16K cycles, if there is no delay caused by internal processing. By using this method, roughly 64 GB of memory behind the IO hub will be scrubbed every day. The options are **Enable** and Disable.

Patrol Scrub Interval

This feature allows you to decide how many hours the system should wait before the next complete patrol scrub is performed. Use the keyboard to enter a value from 0-24. The Default setting is **24**.

Demand Scrub

Demand Scrubbing is a process that allows the CPU to correct correctable memory errors found on a memory module. When the CPU or I/O issues a demand-read command, and the read data from memory turns out to be a correctable error, the error is corrected and sent to the requestor (the original source). Memory is updated as well. Select Enable to use Demand Scrubbing for ECC memory correction. The options are **Enable** and Disable.

Device Tagging

Select Enable to support device tagging. The options are **Disable** and Enable.

►South Bridge Configuration

The following South Bridge information will display:

- USB Configuration
- USB Module Version
- USB Devices

Legacy USB Support

Select Enabled to support onboard legacy USB devices. Select Auto to disable legacy support if there are no legacy USB devices present. Select Disable to have all USB devices available for EFI applications only. The options are **Enabled**, Disabled and Auto.

XHCI Hand-Off

This is a work-around solution for operating systems that do not support XHCI (Extensible Host Controller Interface) hand-off. The XHCI ownership change should be claimed by the XHCI driver. The settings are **Enabled** and Disabled.

EHCI Hand-Off

This item is for operating systems that do not support Enhanced Host Controller Interface (EHCI) hand-off. When this item is enabled, EHCI ownership change will be claimed by the EHCI driver. The settings are Enabled and **Disabled**.

Port 60/64 Emulation

Select Enabled for I/O port 60h/64h emulation support, which in turn, will provide complete legacy USB keyboard support for the operating systems that do not support legacy USB devices. The options are Disabled and **Enabled**.

USB 3.0 Support

Select Enabled for USB 3.0 support. The options are Smart Auto, **Auto**, Enabled, Disabled and Manual.

►SATA Configuration

When this submenu is selected, AMI BIOS automatically detects the presence of the SATA devices that are supported by the Intel PCH chip and displays the following items:

SATA Controller

This item enables or disables the onboard SATA controller supported by the Intel PCH chip. The options are **Enabled** and Disabled.

Configure SATA as

Select IDE to configure a SATA drive specified by the user as an IDE drive. Select AHCI to configure a SATA drive specified by the user as an AHCI drive. Select RAID to configure a SATA drive specified by the user as a RAID drive. The options are IDE, **AHCI**, and RAID.

**If the item above "Configure SATA as" is set to AHCI, the following items will display:*

Support Aggressive Link Power Management

When this item is set to **Enabled**, the SATA AHCI controller manages the power usage of the SATA link. The controller will put the link to a low power state when the I/O is inactive for an extended period of time, and the power state will return to normal when the I/O becomes active. The options are **Enabled** and **Disabled**.

SATA Port 0~ Port 5

This item displays the information detected on the installed SATA drive on the particular SATA port.

- Model number of drive and capacity
- Software Preserve Support

Port 0~ Port 5

Select **Enabled** to enable a SATA port specified by the user. The options are **Disabled** and **Enabled**.

Port 0 ~ Port 5 Hot Plug

Select **Enabled** to enable hot-plugging support for a port specified by the user, which will allow the user to replace a SATA disk drive installed on this port without shutting down the system. The options are **Enabled** and **Disabled**.

Port 0 ~ Port 5 Spin Up Device

On an edge detect from 0 to 1, set this item to allow the PCH to initialize the device. The options are **Enabled** and **Disabled**.

Port 0 ~ Port 5 SATA Device Type

Use this item to specify if the SATA port specified by the user should be connected to a Solid State drive or a Hard Disk Drive. The options are **Hard Disk Drive** and **Solid State Drive**.

**If the item above "Configure SATA as" is set to IDE, the following items will display:*

Serial ATA Port 0~ Port 5

This item indicates that a SATA port specified by the user is installed (present) or not.

Port 0 ~ Port 5 SATA Device Type (Available when a SATA port is detected)

Use this item to specify if the SATA port specified by the user should be connected to a Solid State drive or a Hard Disk Drive. The options are Hard Disk Drive and Solid State Drive.

**If the item above "Configure SATA as" is set to RAID, the following items will display:*

Support Aggressive Link Power Management

When this item is set to Enabled, the SATA AHCI controller manages the power usage of the SATA link. The controller will put the link to a low power state when the I/O is inactive for an extended period of time, and the power state will return to normal when the I/O becomes active. The options are **Enabled** and Disabled.

SATA RAID Option ROM/UEFI Driver

Select EFI to load the EFI driver for system boot. Select Legacy to load a legacy driver for system boot. The options are Disabled, EFI, and **Legacy**.

Serial ATA Port 0~ Port 5

This item displays the information detected on the installed SATA drives on the particular SATA port.

- Model number of drive and capacity
- Software Preserve Support

Port 0~ Port 5

Select Enabled to enable a SATA port specified by the user. The options are Disabled and **Enabled**.

Port 0 ~ Port 5 Hot Plug

Select Enabled to enable hot-plugging support for a port specified by the user, which will allow the user to replace a SATA disk drive installed on this port without shutting down the system. The options are Enabled and **Disabled**.

Port 0 ~ Port 5 Spin Up Device

On an edge detect from 0 to 1, set this item to allow the PCH to start a COMRESET initialization to the device. The options are Enabled and **Disabled**.

Port 0 ~ Port 5 SATA Device Type

Use this item to specify if the SATA port specified by the user should be connected to a Solid State drive or a Hard Disk Drive. The options are Hard Disk Drive and Solid State Drive.

►sSATA Configuration

When this submenu is selected, AMI BIOS automatically detects the presence of the SATA devices that are supported by the PCH-sSATA controller and displays the following items:

sSATA Controller

This item enables or disables the onboard SATA controller supported by the Intel PCH-sSATA controller. The options are **Enabled** and Disabled.

Configure sSATA as

Select IDE to configure an sSATA drive specified by the user as an IDE drive. Select AHCI to configure an sSATA drive specified by the user as an AHCI drive. Select RAID to configure an sSATA drive specified by the user as a RAID drive. The options are IDE, **AHCI**, and RAID.

**If the item above "Configure sSATA as" is set to AHCI, the following items will display:*

Support Aggressive Link Power Management

When this item is set to Enabled, the SATA AHCI controller manages the power usage of the SATA link. The controller will put the link to a low power state when the I/O is inactive for an extended period of time, and the power state will return to normal when the I/O becomes active. The options are **Enabled** and Disabled.

sSATA Port 0~ Port 3

This item displays the information detected on the installed on the sSATA port. specified by the user.

- Model number of drive and capacity
- Software Preserve Support

sSATA Port 0~ Port 3

Select Enabled to enable an sSATA port specified by the user. The options are Disabled and Enabled.

sSATA Port 0 ~ Port 3 Hot Plug

Select Enabled to enable hot-plugging support for a port specified by the user, which will allow the user to replace a sSATA disk drive installed on this port without shutting down the system. The options are **Enabled** and Disabled.

sSATA Port 0 ~ Port 3 Spin Up Device

On an edge detect from 0 to 1, set this item to allow the PCH to start a COM-RESET initialization to the device. The options are Enabled and **Disabled**.

Port 0 ~ Port 3 sSATA Device Type

Use this item to specify if the sSATA port specified by the user should be connected to a Solid State drive or a Hard Disk Drive. The options are Hard Disk Drive and Solid State Drive.

**If the item above "Configure sSATA as" is set to IDE, the following items will display:*

sSATA Port 0~ Port 3

This item indicates that an sSATA port specified by the user is installed (present) or not.

Port 0 ~ Port 3 sSATA Device Type (Available when a SATA port is detected)

Use this item to specify if the sSATA port specified by the user should be connected to a Solid State drive or a Hard Disk Drive. The options are Hard Disk Drive and Solid State Drive.

**If the item above "Configure sSATA as" is set to RAID, the following items will display:*

Support Aggressive Link Power Management

When this item is set to Enabled, the SATA AHCI controller manages the power usage of the SATA link. The controller will put the link to a low power state when the I/O is inactive for an extended period of time, and the power state will return to normal when the I/O becomes active. The options are **Enabled** and Disabled.

sSATA RAID Option ROM/UEFI Driver

Select EFI to load the EFI driver for system boot. Select Legacy to load a legacy driver for system boot. The options are Disabled, EFI, and **Legacy**.

SATA/sSATA RAID Boot Select

Use this item to specify which controller for the system to boot from. The options are SATA Controller, **sSATA Controller**, and Both.

sSATA Port 0~ Port 1

This item displays the information detected on the installed sSATA drives on the particular sSATA port.

- Model number of drive and capacity
- Software Preserve Support

sSATA Port 0~ Port 3

Select Enabled to enable an sSATA port specified by the user. The options are Disabled and Enabled.

sSATA Port 0 ~ Port 3 Hot Plug

This feature designates this port for hot plugging. Set this item to Enabled for hot-plugging support, which will allow the user to replace an sSATA drive without shutting down the system. The options are Enabled and **Disabled**.

sSATA Port 0 ~ Port 3 Spin Up Device

On an edge detect from 0 to 1, set this item to allow the PCH to start a COMRESET initialization to the device. The options are Enabled and **Disabled**.

Port 0 ~ Port 3 sSATA Device Type

Use this item to specify if the sSATA port specified by the user should be connected to a Solid State drive or a Hard Disk Drive. The options are Hard Disk Drive and Solid State Drive.

► Server ME (Management Engine) Configuration

This feature displays the following system ME configuration settings.

- General ME Configuration
- Operational Firmware Version
- ME Firmware Type
- Recovery Firmware Version
- ME Firmware Features
- ME Firmware Status #1
- ME Firmware Status #2

- Current State
- Error Code

► PCIe/PCI/PnP Configuration

The following PCI information will be displayed:

- PCI Bus Driver Version

PCI Latency Timer

Use this item to configure the PCI latency timer for a device installed on a PCI bus. Select 32 to set the PCI latency timer to 32 PCI clock cycles. The options are **32**, 64, 96, 128, 160, 192, 224 and 248 (PCI Bus Clocks).

PCI PERR# Generation

Enabling this setting will allow the BIOS to generate a PERR number when a run-time PERR (PCI/PCI-E Parity Error) event occurs on a PCI/PCI-E slot for PERR reporting. The options are Enabled and Disabled.

PCI SERR# Support

Enabling this setting will allow the BIOS to generate a SERR number when a runtime SERR (System Error) event occurs on a PCI/PCI-E slot for SERR reporting. The options are Enabled and **Disabled**.

PCI PERR/SERR Support

Select Enabled to allow a PCI device to generate a PERR/SERR number for a PCI Bus Signal Error Event. The options are Enabled and **Disabled**.

Above 4G Decoding (Available if the system supports 64-bit PCI decoding)

Select Enabled to decode a PCI device that supports 64-bit in the space above 4G Address. The options are Enabled and **Disabled**.

SR-IOV (Available if the system supports Single-Root Virtualization)

Select Enabled for Single-Root IO Virtualization support. The options are Enabled and **Disabled**.

Maximum Payload

Select Auto for the system BIOS to automatically set the maximum payload value for a PCI-E device to enhance system performance. The options are **Auto**, 128 Bytes, and 256 Bytes.

Maximum Read Request

Select Auto for the system BIOS to automatically set the maximum size for a read request for a PCI-E device to enhance system performance. The options are **Auto**, 128 Bytes, 256 Bytes, 512 Bytes, 1024 Bytes, 2048 Bytes, and 4096 Bytes.

ASPM Support

Use this item to set the Active State Power Management (ASPM) level for a PCI-E device. Select Auto for the system BIOS to automatically set the ASPM level based on the system configuration. Select Disabled to disable ASPM support. The options are **Disabled**, and Auto.

Warning: Enabling ASPM support may cause some PCI-E devices to fail!

MMIOHBase

Use this item to select the base memory size according to memory-address mapping for the IO hub. The base memory size must be between 4032G to 4078G. The options are **56T**, 48T, 24T, 512G, and 256G.

MMIO High Size

Use this item to select the high memory size according to memory-address mapping for the IO hub. The options are 256G, 128G, **512G**, and 1024G.

CPU2 SLOT1 PCI-E 3.0 x8 OPRPM
CPU1 SLOT2 PCI-E 3.0 x8 OPRPM
CPU2 GPU SLOT1 PCI-E 3.0 x16 OPRPM
CPU2 GPU SLOT2 PCI-E 3.0 x16 OPRPM
CPU1 GPU SLOT3 PCI-E 3.0 x16 OPRPM
CPU1 GPU SLOT4 PCI-E 3.0 x16 OPRPM

Select Enabled to enable Option ROM support to boot the computer using a device installed on the slot specified by the user. The options are Disabled, **Legacy** and EFI.

VGA Priority

Use this item to select the graphics device to be used as the primary video display for system boot. The options are **Onboard** and Offboard.

Onboard LAN Option ROM Type

Select Enabled to enable Option ROM support to boot the computer using a network device specified by the user. The options are Disabled, **Legacy** and EFI.

Onboard LAN1 OPROM
Onboard LAN2 OPROM

Use this option to select the type of device installed in LAN Port1, LAN Port2, LAN Port3, LAN Port4, or the onboard video device used for system boot. The

default setting for LAN1 Option ROM is **PXE, Disabled** for LAN2 Option ROM, and **Legacy** for Onboard Video Option ROM.

►Super IO Configuration

Super IO Chip AST2400

►Serial Port 1 Configuration/Serial Port 2 Configuration

Serial Port 1/Serial Port 2

Select Enabled to enable the onboard serial port specified by the user. The options are **Enabled** and Disabled.

Device Settings

This item displays the base I/O port address and the Interrupt Request address of a serial port specified by the user.

Change Port 1 Settings/Change Port 2 Settings

This feature specifies the base I/O port address and the Interrupt Request address of Serial Port 1 or Serial Port 2. Select **Auto** for the BIOS to automatically assign the base I/O and IRQ address to a serial port specified.

The options for Serial Port 1 are **Auto**, (IO=3F8h; IRQ=4), (IO=3F8h; IRQ=3, 4, 5, 6, 7, 9, 10, 11, 12), (IO=2F8h; IRQ=3, 4, 5, 6, 7, 9, 10, 11, 12); (IO=3E8h; IRQ=3, 4, 5, 6, 7, 9, 10, 11, 12), and (IO=2E8h; IRQ=3, 4, 5, 6, 7, 9, 10, 11, 12).

The options for Serial Port 2 are **Auto**, (IO=3F8h; IRQ=4), (IO=3F8h; IRQ=3, 4, 5, 6, 7, 9, 10, 11, 12), (IO=2F8h; IRQ=3, 4, 5, 6, 7, 9, 10, 11, 12); (IO=3E8h; IRQ=3, 4, 5, 6, 7, 9, 10, 11, 12), and (IO=2E8h; IRQ=3, 4, 5, 6, 7, 9, 10, 11, 12).

Serial Port 2 Attribute

Select SOL to use COM Port 2 as a Serial_Over_LAN (SOL) port for console redirection. The options are COM and **SOL**.

►Serial Port Console Redirection

COM 1

COM 1 Console Redirection

Select Enabled to enable COM Port 1 Console Redirection, which will allow a client machine to be connected to a host machine at a remote site for networking. The options are **Disabled** and Enabled.

**If the item above set to Enabled, the following items will become available for configuration:*

►COM1 Console Redirection Settings

Terminal Type

This feature allows the user to select the target terminal emulation type for Console Redirection. Select VT100 to use the ASCII Character set. Select VT100+ to add color and function key support. Select ANSI to use the Extended ASCII Character Set. Select VT-UTF8 to use UTF8 encoding to map Unicode characters into one or more bytes. The options are ANSI, VT100, **VT100+**, and VT-UTF8.

Bits Per second

Use this item to set the transmission speed for a serial port used in Console Redirection. Make sure that the same speed is used in the host computer and the client computer. A lower transmission speed may be required for long and busy lines. The options are 9600, 19200, 38400, 57600 and **115200** (bits per second).

Data Bits

Use this feature to set the data transmission size for Console Redirection. The options are 7 (Bits) and **8 (Bits)**.

Parity

A parity bit can be sent along with regular data bits to detect data transmission errors. Select Even if the parity bit is set to 0, and the number of 1's in data bits is even. Select Odd if the parity bit is set to 0, and the number of 1's in data bits is odd. Select None if you do not want to send a parity bit with your data bits in transmission. Select Mark to add a mark as a parity bit to be sent along with the data bits. Select Space to add a Space as a parity bit to be sent with your data bits. The options are **None**, Even, Odd, Mark and Space.

Stop Bits

A stop bit indicates the end of a serial data packet. Select 1 Stop Bit for standard serial data communication. Select 2 Stop Bits if slower devices are used. The options are **1** and 2.

Flow Control

Use this item to set the flow control for Console Redirection to prevent data loss caused by buffer overflow. Send a "Stop" signal to stop sending data when the receiving buffer is full. Send a "Start" signal to start sending data when the receiving buffer is empty. The options are **None** and Hardware RTS/CTS.

VT-UTF8 Combo Key Support

Select Enabled to enable VT-UTF8 Combination Key support for ANSI/VT100 terminals. The options are **Enabled** and Disabled.

Recorder Mode

Select Enabled to capture the data displayed on a terminal and send it as text messages to a remote server. The options are **Disabled** and Enabled.

Resolution 100x31

Select Enabled for extended-terminal resolution support. The options are Disabled and **Enabled**.

Legacy OS Redirection Resolution

Use this item to select the number of rows and columns used in Console Redirection for legacy OS support. The options are 80x24 and **80x25**.

Putty KeyPad

This feature selects Function Keys and KeyPad settings for Putty, which is a terminal emulator designed for the Windows OS. The options are **VT100**, LINUX, XTERMR6, SCO, ESCN, and VT400.

Redirection After BIOS POST

Use this feature to enable or disable legacy Console Redirection after BIOS POST. When the option-Bootloader is selected, legacy Console Redirection is disabled before booting the OS. When the option- Always Enable is selected, legacy Console Redirection remains enabled upon OS bootup. The options are **Always Enable** and Bootloader.

SOL/COM2

Console Redirection

Select Enabled to use the SOL port for Console Redirection. The options are **Enabled** and Disabled.

**If the item above set to Enabled, the following items will become available for user's configuration:*

► SOL/COM2 Console Redirection Settings

Use this feature to specify how the host computer will exchange data with the client computer, which is the remote computer used by the user.

Terminal Type

Use this feature to select the target terminal emulation type for Console Redirection. Select VT100 to use the ASCII Character set. Select VT100+ to add color

and function key support. Select ANSI to use the Extended ASCII Character Set. Select VT-UTF8 to use UTF8 encoding to map Unicode characters into one or more bytes. The options are ANSI, VT100, **VT100+**, and VT-UTF8.

Bits Per second

Use this feature to set the transmission speed for a serial port used in Console Redirection. Make sure that the same speed is used in the host computer and the client computer. A lower transmission speed may be required for long and busy lines. The options are 9600, 19200, 38400, 57600 and **115200** (bits per second).

Data Bits

Use this feature to set the data transmission size for Console Redirection. The options are 7 (Bits) and **8 (Bits)**.

Parity

A parity bit can be sent along with regular data bits to detect data transmission errors. Select Even if the parity bit is set to 0, and the number of 1's in data bits is even. Select Odd if the parity bit is set to 0, and the number of 1's in data bits is odd. Select None if you do not want to send a parity bit with your data bits in transmission. Select Mark to add a mark as a parity bit to be sent along with the data bits. Select Space to add a Space as a parity bit to be sent with your data bits. The options are **None**, Even, Odd, Mark and Space.

Stop Bits

A stop bit indicates the end of a serial data packet. Select 1 Stop Bit for standard serial data communication. Select 2 Stop Bits if slower devices are used. The options are **1** and 2.

Flow Control

Use this feature to set the flow control for Console Redirection to prevent data loss caused by buffer overflow. Send a "Stop" signal to stop sending data when the receiving buffer is full. Send a "Start" signal to start data-sending when the receiving buffer is empty. The options are **None** and Hardware RTS/CTS.

VT-UTF8 Combo Key Support

Select Enabled to enable VT-UTF8 Combination Key support for ANSI/VT100 terminals. The options are **Enabled** and Disabled.

Recorder Mode

Select Enabled to capture the data displayed on a terminal and send it as text messages to a remote server. The options are **Disabled** and Enabled.

Resolution 100x31

Select Enabled for extended-terminal resolution support. The options are Disabled and **Enabled**.

Legacy OS Redirection Resolution

Use this feature to select the number of rows and columns used in Console Redirection for legacy OS support. The options are 80x24 and **80x25**.

Putty KeyPad

This feature selects Function Keys and KeyPad settings for Putty, which is a terminal emulator designed for the Windows OS. The options are **VT100**, LINUX, XTERMR6, SCO, ESCN, and VT400.

Redirection After BIOS POST

Use this feature to enable or disable legacy Console Redirection after BIOS POST (Power-On Self-Test). When this feature is set to Bootloader, legacy Console Redirection is disabled before booting the OS. When this feature is set to Always Enable, legacy Console Redirection remains enabled upon OS boot. The options are **Always Enable** and Bootloader.

► EMS Console Redirection Settings

Out-of-Band Management Port

The feature selects a serial port in a client server to be used by the Windows Emergency Management Services (EMS) to communicate with a remote host server. The options are **COM1 (Console Redirection)** and COM2/SOL (Console Redirection).

Terminal Type

Use this feature to select the target terminal emulation type for Console Redirection. Select VT100 to use the ASCII character set. Select VT100+ to add color and function key support. Select ANSI to use the extended ASCII character set. Select VT-UTF8 to use UTF8 encoding to map Unicode characters into one or more bytes. The options are ANSI, VT100, VT100+, and **VT-UTF8**.

Bits Per Second

This item sets the transmission speed for a serial port used in Console Redirection. Make sure that the same speed is used in both host computer and the client

computer. A lower transmission speed may be required for long and busy lines. The options are 9600, 19200, 57600, and **115200** (bits per second).

Flow Control

Use this item to set the flow control for Console Redirection to prevent data loss caused by buffer overflow. Send a "Stop" signal to stop data-sending when the receiving buffer is full. Send a "Start" signal to start data-sending when the receiving buffer is empty. The options are **None**, Hardware RTS/CTS, and Software Xon/Xoff.

The setting for each these features is displayed:

Data Bits, Parity, Stop Bits

►ACPI Settings

WHEA Support

Select Enabled to support the Windows Hardware Error Architecture (WHEA) platform and provide a common infrastructure for the system to handle hardware errors within the Windows OS environment to reduce system crashes and to enhance system recovery and health monitoring. The options are Enabled and **Disabled**.

High Precision Timer

Select Enabled to activate the High Precision Event Timer (HPET) that produces periodic interrupts at a much higher frequency than a Real-time Clock (RTC) does in synchronizing multimedia streams, providing smooth playback and reducing the dependency on other timestamp calculation devices, such as an x86 RDTSC Instruction embedded in the CPU. The High Performance Event Timer is used to replace the 8254 Programmable Interval Timer. The options are **Enabled** and Disabled.

NUMA (Available when the OS supports this feature)

Select Enabled to enable Non-Uniform Memory Access support to enhance system performance. The options are **Enabled** and Disabled.

7-4 Event Logs

Use this tab page to configure Event Log settings.

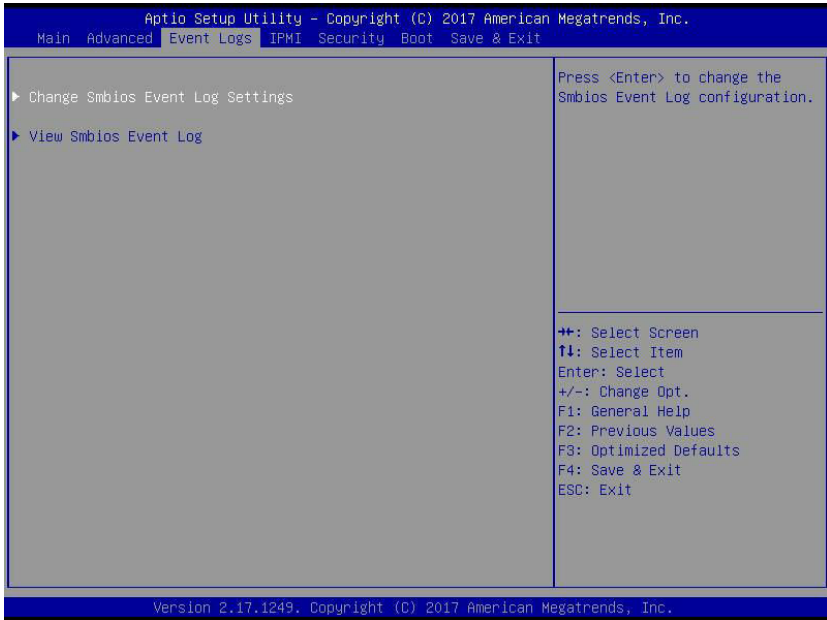

Change SMBIOS Event Log Settings

This feature allows the user to configure SMBIOS Event settings.

Enabling/Disabling Options

SMBIOS Event Log

Select Enabled to enable SMBIOS (System Management BIOS) Event Logging during system boot. The options are **Enabled** and Disabled.

Runtime Error Logging Support

Select Enabled to support Runtime Error Logging. The options are **Enabled** and Disabled. If this item is set to Enable, the following item will be available for configuration:

Erasing Settings

Erase Event Log

Select Enabled to erase all error events in the SMBIOS (System Management BIOS) log before an event logging is initialized at bootup. The options are **No** and Yes.

When Log is Full

Select Erase Immediately to immediately erase all errors in the SMBIOS event log when the event log is full. Select Do Nothing for the system to do nothing when the SMBIOS event log is full. The options are **Do Nothing** and Erase Immediately.

SMBIOS Event Log Standard Settings

Log System Boot Event

Select Enabled to log system boot events. The options are **Disabled** and Enabled.

MECI (Multiple Event Count Increment)

Enter the increment value for the multiple event counter. Enter a number between 1 to 255. The default setting is **1**.

METW (Multiple Event Count Time Window)

This item is used to determine how long (in minutes) should the multiple event counter wait before generating a new event log. Enter a number between 0 to 99. The default setting is **60**.

Note: Please reboot the system for the changes to take effect.

►View SMBIOS Event Log

This item allows the user to view the event in the SMBIOS event log. Select this item and press <Enter> to view the status of an event in the log. The following categories are displayed:

Date/Time/Error Code/Severity

7-5 IPMI

Select this tab to configure Intelligent Platform Management Interface (IPMI) settings.

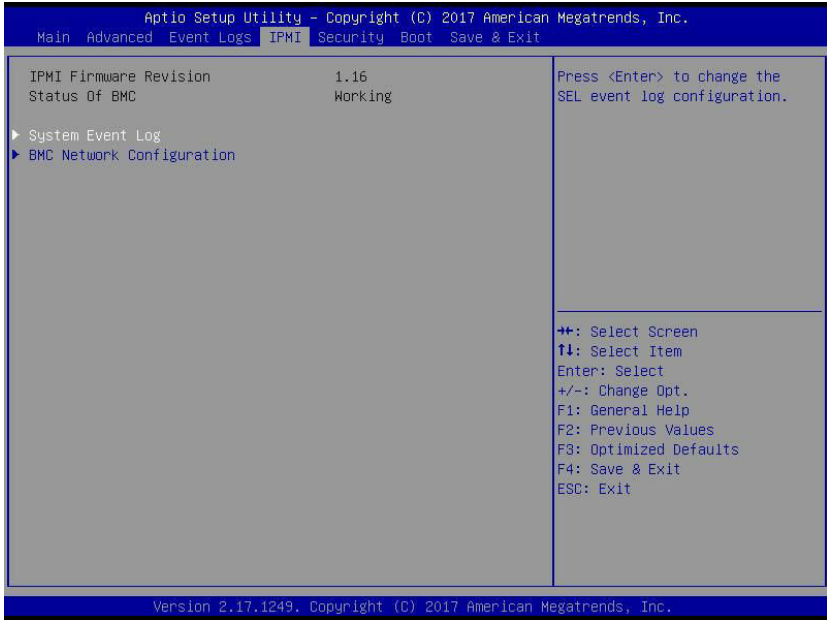

IPMI Firmware Revision

This item indicates the IPMI firmware revision used in your system.

Status of BMC

This item indicates the status of the IPMI firmware installed in your system.

▶ System Event Log

Enabling/Disabling Options

SEL Components

Select Enabled to enable all system event logging support at bootup. The options are **Enabled** and Disabled.

Erasing Settings

Erase SEL

Select Yes, On next reset to erase all system event logs upon next system reboot. Select Yes, On every reset to erase all system event logs upon each system reboot. Select No to keep all system event logs after each system reboot. The options are **No**, Yes, On next reset, and Yes, On every reset.

When SEL is Full

This feature allows the user to determine what the BIOS should do when the system event log is full. Select Erase Immediately to erase all events in the log when the system event log is full. The options are **Do Nothing** and Erase Immediately.

Note: After making changes on a setting, be sure to reboot the system for the changes to take effect.

Custom EFI Logging Options

Log EFI Status Codes

This feature allows the user to determine whether the BIOS will log EFI Status Codes, error code only, progress code only, or both. The options are Disabled, Both, **Error code**, and Progress code

►BMC Network Configuration

The following items will be displayed:

- IPMI LAN Selection
- Current Configuration Address course
- Station IP Address
- Subnet Mask
- Station MAC Address
- Gateway IP Address
- VLAN

Update IPMI LAN Configuration

Select Yes for the system BIOS to automatically reset the following IPMI settings at next system boot. The options are Yes and No.

Configuration Address Source (Available when the item above - Update IPMI LAN Configuration is set to Yes)

Use this item to select the IP address source for this computer. If Static is selected, you will need to know the IP address of this computer and enter it to the system manually in the field. If DHCP is selected, AMI BIOS will search for a DHCP (Dynamic Host Configuration Protocol) server attached to the network and request the next available IP address for this computer. The options are **DHCP** Unspecified, and Static.

Station IP Address

This item displays the Station IP address for this computer. This should be in decimal and in dotted quad form (i.e., 192.168.10.253).

Subnet Mask

This item displays the sub-network that this computer belongs to. The value of each three-digit number is separated by dots and it should not exceed 255.

Station MAC Address

This item displays the Station MAC address for this computer. Mac addresses are 6 two-digit hexadecimal numbers.

Gateway IP Address

This item displays the Gateway IP address for this computer. This should be in decimal and in dotted quad form (i.e., 192.168.10.253).

When you have completed the system configuration changes, select this option to save the changes and reboot the computer so that the new system configuration settings can take effect. Select Save Changes and Exit, and press <Enter>. When the dialog box appears, asking you if you want to exit the BIOS setup without saving, click **Yes** to quit BIOS without saving the changes, or click No to quit the BIOS and save changes.

7-6 Security

Select this tab to configure security settings.

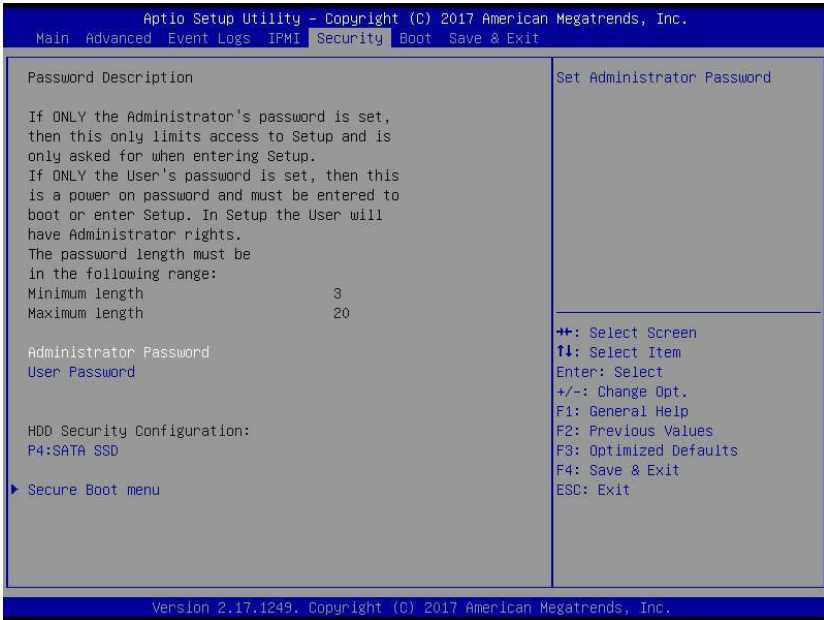

Password Description

Administrator Password

Use this feature to set the administrator password which is required before entering the BIOS setup utility. The length of the password should be from 3 characters to 20 characters long.

User Password

Use this feature to set the user password which is required to enter the BIOS setup utility. The length of the password should be from 3 characters to 20 characters long.

7-7 Boot

Select this tab to configure boot settings.

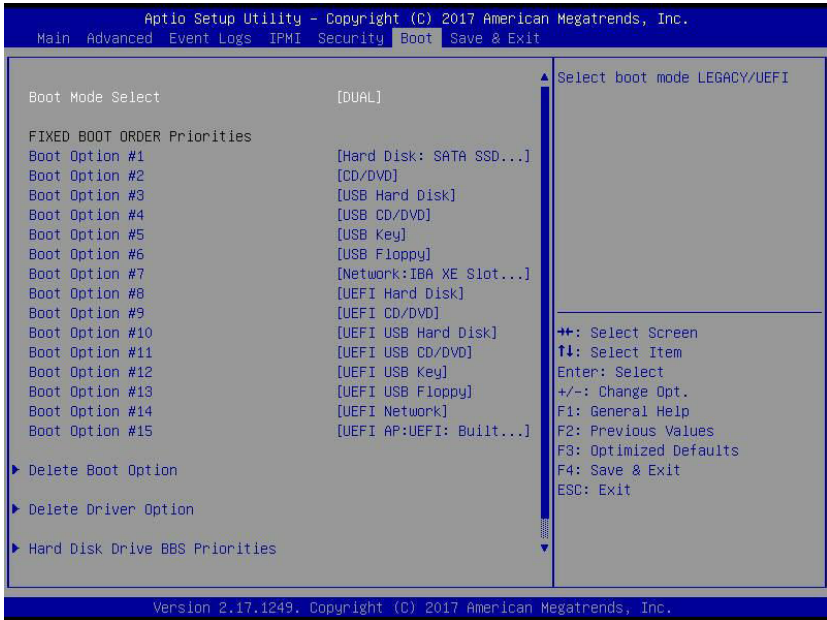

Boot Configuration

Boot Mode Select

Use this item to select the type of device to be used for system boot. The options are Legacy, UEFI, and **Dual**.

Fixed Boot Order Priorities

This option prioritizes the order of bootable devices from which the system will boot. Press <Enter> on each entry from top to bottom to select devices.

- Dual Boot Order #1
- Dual Boot Order #2
- Dual Boot Order #3
- Dual Boot Order #4
- Dual Boot Order #5

- Dual Boot Order #6
- Dual Boot Order #7
- Dual Boot Order #8
- Dual Boot Order #9
- Dual Boot Order #10
- Dual Boot Order #11
- Dual Boot Order #12
- Dual Boot Order #13
- Dual Boot Order #14
- Dual Boot Order #15

▶ **Delete Boot Option**

Use this item to select a boot device to delete from the boot priority list.

Delete Boot Option

Select the target boot device to delete.

▶ **Delete Driver Option**

Use this item to select a boot device to delete from the boot priority list.

Delete Driver Option

Select the target driver device to delete.

▶ **Hard Disk Drive BBS Priorities**

- Legacy Boot Order #1 - Legacy Boot Order #10

▶ **Network Drive BBS Priorities**

- Legacy Boot Order #1 - Legacy Boot Order #3

▶ **UEFI Application Boot Priorities**

- UEFI Boot Order #1

7-8 Save & Exit

Select this tab to configure settings for saving and exiting.

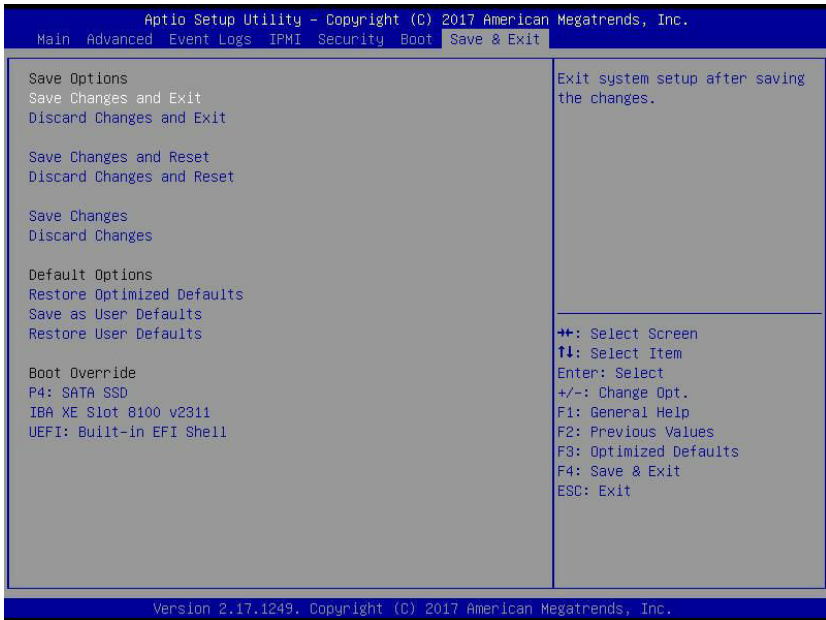

Save Options

Save Changes and Exit

When you have completed the system configuration changes, select this option to leave the BIOS setup utility and reboot the computer for the new system configuration parameters can take effect. Select Save Changes and Exit from the Exit menu and press <Enter>.

Discard Changes and Exit

Select this option to quit the BIOS setup without making any permanent changes to the system configuration, and reboot the computer. Select Discard Changes and Exit from the Exit menu and press <Enter>.

Save Changes

When you have completed the system configuration changes, select this option to save all changes made. This will not reset (reboot) the system.

Discard Changes

Select this option and press <Enter> to discard all the changes and return to the AMI BIOS Utility Program.

Default Options

Restore Optimized Defaults

To set this feature, select Restore Defaults from the Exit menu and press <Enter>. These are manufacture default settings designed for maximum system performance but not for maximum stability.

Save As User Defaults

To set this feature, select Save as User Defaults from the Exit menu and press <Enter>. This enables the user to save any changes to the BIOS setup for future use.

Restore User Defaults

To set this feature, select Restore User Defaults from the Exit menu and press <Enter>. Use this feature to retrieve user-defined settings that were saved previously.

Boot Override

This feature allows the user to override the Boot priorities sequence in the Boot menu, and immediately boot the system with another device specified by the user. This is a one-time override.

Appendix A

BIOS Error Beep Codes

During the POST (Power-On Self-Test) routines, which are performed at each system boot, errors may occur.

Non-fatal errors are those which, in most cases, allow the system to continue to boot. The error messages normally appear on the screen.

Fatal errors will not allow the system to continue with bootup procedure. If a fatal error occurs, you should consult with your system manufacturer for possible repairs.

These fatal errors are usually communicated through a series of audible beeps. The numbers on the fatal error list correspond to the number of beeps for the corresponding error.

| BIOS Error Beep Codes | | |
|-----------------------------|---------------------------------|--|
| Beep Code/LED | Error Message | Description |
| 1 beep | Refresh | Ready to boot |
| 5 short beeps + 1 long beep | Memory error | No memory detected in the system |
| 5 beeps | No Con-In or No Con-Out devices | Con-In: USB or PS/2 keyboard, PCI or Serial Console Redirection, IPMI KVM or SOL Con-Out: Video Controller, PCI or Serial Console Redirection, IPMI SOL |
| X10 IPMI Error Codes | | |
| 1 Continuous Beep | System OH | System Overheat |

Notes

Appendix B

System Specifications

Processors

Two Intel Xeon E5-2600 v3/v4 series processors in Socket R LGA 2011 type sockets

Chipset

Intel C612 chipset

BIOS

128Mb SPI Flash EEPROM with AMI BIOS

Memory Capacity

Twenty four DIMM slots support up to 1.5 TB of Load Reduced (LRDIMM) or Registered (RDIMM) DDR4 ECC, 288-pin, at 2400/2133/1866/1600/1333 MHz. DIMMs up to 64 GB at 1.2V.

Note: Refer to Section 5-5 for details on installation. Check the Supermicro website (www.supermicro.com) for the latest memory support information.

Storage Drive Bays

Sixteen hot-swap bays for 2.5" SAS/SATA drives; supports eight NVMe drives

GPUs (Graphics Processing Units)

Eight PASCAL SXM2 P100 GPUs

PCI Expansion

Four PCI Express 3.0 x16 low profile slots, two PCI Express x8 low profile slots

Motherboard

X10DGO(-T) (proprietary form factor)

Dimensions: 17 x 19 in. (43.2 x 48.3 mm)

Chassis

SCR422BG (4U rackmount)

Dimensions: (HxWxD) 7.0 x 17.6 x 31.7 in. (178 x 447 x 805 mm)

Weight

Net Weight: 80 lbs (36.2 kg)

Gross Weight: 135 lbs (61.2 kg)

System Cooling

Eight 9-cm hot-swap cooling fans, two air shrouds, two CPU heatsinks, eight GPU heatsinks

System Input Requirements

AC Input Voltage: 100-240VAC auto-range

Total Output Power and Input:

1200W / 100-127 Vac

1800W / 200-220 Vac

1980W / 220-230 Vac

2090W / 230-240 Vac

Rated Input Frequency: 50 to 60 Hz

Power Supplies

PWS-2K21A-2R 80PLUS level Titanium

Rated Output Power:

+12V:

Max: 100A / Min: 0A (100Vac-127Vac)

Max: 150A / Min: 0A (200Vac-220Vac)

Max: 165A / Min: 0A (220Vac-230Vac)

Max: 174.17A / Min: 0A (230Vac-240Vac)

Max: 183.3A / Min: 0A (220Vac-240Vac)

Max: 174.17A / Min: 0A (180Vac-220Vac)

Max: 183.3A / Min: 0A (-)

Max: 174.17A / Min: 0A (-)

12Vsb: Max: 2A / Min: 0A

Fan Power Supply: (PWS-DF004-1F) four 12 Vdc input redundant FAN module power supporting I²C function

Operating Environment

Operating Temperature: 10° to 35° C (50° to 95° F)

Non-operating Temperature: -40° to 70° C (-40° to 158° F)

Operating Relative Humidity: 8% to 90% (non-condensing)

Non-operating Relative Humidity: 5 to 95% (non-condensing)

Regulatory Compliance

Electromagnetic Emissions: FCC Class A, EN 55022 Class A, EN 61000-3-2/-3-3, CISPR 22 Class A

Electromagnetic Immunity: EN 55024/CISPR 24, (EN 61000-4-2, EN 61000-4-3, EN 61000-4-4, EN 61000-4-5, EN 61000-4-6, EN 61000-4-8, EN 61000-4-11)

Safety: CSA/EN/IEC/UL 60950-1 Compliant, UL or CSA Listed (USA and Canada), CE Marking (Europe)

California Best Management Practices Regulations for Perchlorate Materials:
This Perchlorate warning applies only to products containing CR (Manganese Dioxide) Lithium coin cells. "Perchlorate Material-special handling may apply. See www.dtsc.ca.gov/hazardouswaste/perchlorate" for further details.

(continued from front)

The products sold by Supermicro are not intended for and will not be used in life support systems, medical equipment, nuclear facilities or systems, aircraft, aircraft devices, aircraft/emergency communication devices or other critical systems whose failure to perform be reasonably expected to result in significant injury or loss of life or catastrophic property damage. Accordingly, Supermicro disclaims any and all liability, and should buyer use or sell such products for use in such ultra-hazardous applications, it does so entirely at its own risk. Furthermore, buyer agrees to fully indemnify, defend and hold Supermicro harmless for and against any and all claims, demands, actions, litigation, and proceedings of any kind arising out of or related to such ultra-hazardous use or sale.