WRL Technical Note TN-37



Boolean Matching for Full-Custom ECL Gates

Robert N. Mayo
Herve Touati

The Western Research Laboratory (WRL) is a computer systems research group that was founded by Digital Equipment Corporation in 1982. Our focus is computer science research relevant to the design and application of high performance scientific computers. We test our ideas by designing, building, and using real systems. The systems we build are research prototypes; they are not intended to become products.

There two other research laboratories located in Palo Alto, the Network Systems Laboratory (NSL) and the Systems Research Center (SRC). Other Digital research groups are located in Paris (PRL) and in Cambridge, Massachusetts (CRL).

Our research is directed towards mainstream high-performance computer systems. Our prototypes are intended to foreshadow the future computing environments used by many Digital customers. The long-term goal of WRL is to aid and accelerate the development of high-performance uni- and multi-processors. The research projects within WRL will address various aspects of high-performance computing.

We believe that significant advances in computer systems do not come from any single technological advance. Technologies, both hardware and software, do not all advance at the same pace. System design is the art of composing systems which use each level of technology in an appropriate balance. A major advance in overall system performance will require reexamination of all aspects of the system.

We do work in the design, fabrication and packaging of hardware; language processing and scaling issues in system software design; and the exploration of new applications areas that are opening up with the advent of higher performance systems. Researchers at WRL cooperate closely and move freely among the various levels of system design. This allows us to explore a wide range of tradeoffs to meet system goals.

We publish the results of our work in a variety of journals, conferences, research reports, and technical notes. This document is a technical note. We use this form for rapid distribution of technical material. Usually this represents research in progress. Research reports are normally accounts of completed research and may include material from earlier technical notes.

Research reports and technical notes may be ordered from us. You may mail your order to:

Technical Report Distribution
DEC Western Research Laboratory, WRL-2
250 University Avenue
Palo Alto, California 94301 USA

Reports and notes may also be ordered by electronic mail. Use one of the following addresses:

Digital E-net:	DECWRL : : WRL-TECHREPORTS
Internet:	WRL-Techreports@decwrl.dec.com
UUCP:	decwrl!wrl-techreports

To obtain more details on ordering by electronic mail, send a message to one of these addresses with the word "help" in the Subject line; you will receive detailed instructions.

Boolean Matching for Full-Custom ECL Gates

Robert N. Mayo

Herve Touati

June 1993



Western Research Laboratory 250 University Avenue Palo Alto, California 94301 USA

Abstract

@AbstractForm{ TitleString="Boolean Matching for Full-Custom ECL Gates", AuthorString="Robert N. Mayo, Herve Touati", LabName="Western Research Laboratory", DocDate ="June 1993", DocLabel="Technical Note TN-37", DocTag="TN-37", AbsBody={ We present a technology mapper for full-custom ECL gates. These gates are characterized by high fanins and a regular structure. Full-custom gates differ from ECL library gates in that a full range of structures is available as a single form, rather than a large number of individual gates that sparsely cover the possible design space.

This paper presents a complete boolean matching algorithm and gives a proof of its correctness. We show that it can efficiently map logic into the general ECL gate form. We also show two variants of the algorithm, and show that they give poorer results with no savings in runtime.

The mapper described in the paper is a necessary component of a CAD system for designing ECL microprocessors. Manual design of full-custom ECL gates would not be acceptable for control logic since it is a tedious, error prone, and lengthy activity. Nor would a gate-array style mapper and library with a limited number of gates be acceptable, because this makes less effective use of the inherent speed of the technology. } }

Copyright © 1993 Digital Equipment Corporation

Abstract

We present a technology mapper for full-custom ECL gates. These gates are characterized by high fanins and a regular structure. Full-custom gates differ from ECL library gates in that a full range of structures is available as a single form, rather than a large number of individual gates that sparsely cover the possible design space.

This paper presents a complete boolean matching algorithm and gives a proof of its correctness. We show that it can efficiently map logic into the general ECL gate form. We also show two variants of the algorithm, and show that they give poorer results with no savings in runtime.

The mapper described in the paper is a necessary component of a CAD system for designing ECL microprocessors. Manual design of full-custom ECL gates would not be acceptable for control logic since it is a tedious, error prone, and lengthy activity. Nor would a gate-array style mapper and library with a limited number of gates be acceptable, because this makes less effective use of the inherent speed of the technology.

1 Introduction

This paper presents a specialized form of boolean function mapping that is efficient for full-custom designs in the ECL (Emitter Coupled Logic) circuit family. By full-custom we mean the gates are not selected from a library, but are instead built as needed within the bounds of what the technology allows. This allows us to have many more gates than could be placed in a library. Existing libraries[7] contain only a portion of the possible gates, resulting in both wasted area and time.

Our current application is a full-custom 64 bit ECL BiCMOS microprocessor. The characteristics of ECL important to this application are: complex gates with wide fanins, free negation of gate outputs, low gate delays, low wiring delays (due to low logic swings and high currents), and a density comparable to CMOS for structures other than RAM. The combination of these factors allows implementation of fast microprocessors where power consumption is not important and where CMOS RAM may be implemented elsewhere on the same chip, as is the case in our application. The advantages of ECL have been demonstrated with an experimental 300Mhz 115W 32b full-custom ECL microprocessor called BIPS0. [4]

The technology mapper described in this paper takes advantage of two particular features of ECL: high fanin and a regular gate structure. The mapper is an essential part of the CAD system[6] we are using to design our next generation ECL microprocessor.

2 ECL Gates

ECL is a current-steering technology. That is, a current source provides a fixed amount of current, which is then routed in one of two directions using differential pairs of transistors (Figure 1). The differential pair works by comparing the voltages on the bases (inputs) of the transistors, and routing the current through the transistor that has the highest base voltage. In addition to voltages corresponding to logic values 1 and 0, a voltage is available that corresponds to the logic value 0.5. This allows us to route current with only a single input, rather than requiring two inputs that are complements of each other. This voltage is called the reference voltage, or V_r .

Legal circuits will never split current between paths, except for the special *OR* configuration where several transistors reconverge the currents immediately. Figure 2 shows an example gate where currents can split between the *OR* configured transistors connected to i_0 and i_1 , but reconverge immediately.

Current may be routed through more than one level of differential pairs and then finally to a resistor. The presence or absence of current through this resistor determines the voltage across it. This voltage is propagated to the output of the gate using a driver called an *Emitter Follower*. Figure 2 shows a gate that implements the function $F = (i_0 + i_1)\overline{i_2}$. If i_0 and i_1 are 0, current is routed from point A to point D, which is pulled low due to the voltage across the resistor. Output

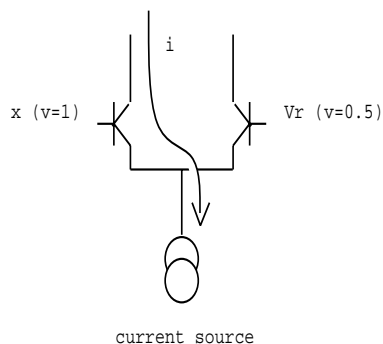

Figure 1: Current Steering

O therefore goes low. There is no current through the other resistor, so \overline{O} is pulled high. If either i_0 or i_1 is 1, then current is routed instead from point A to point B. If i_2 is 1, the current will go to D. Otherwise, it will go to C, pulling it low and setting \overline{O} low. If \overline{O} is low, then there is no current through D so it is high and O is high.

In the most general case, ECL allows n-way current steering, not just 2-way current steering. Current can never be split between paths except in the *OR* configuration. Thus, the designer must ensure that no two inputs in the n-way comparison are high at the same time, or the circuit will malfunction. In addition to n-way splitting, ECL allows more than two resistors, corresponding to more than two outputs. However, only one output can be low at any given time due to the fact that current can only be routed through one resistor at a time. We have chosen to restrict ourselves to 2-way current steering with two resistors. This allows us to use single inputs (or *ORs* of inputs) that are compared to a reference voltage, avoiding the problem of ensuring mutual exclusion. We also choose to only have two outputs per gate, the true and complement values of the function.

ECL families allow the current to pass through a certain number of levels of differential pairs before it gets to a resistor. Each level has a voltage drop associated with it, so the power supply voltage for the chip determines the maximum number of levels that will fit. In our technology we normally use two levels, although a third level is allowed for situations where no reference voltage is needed. To keep things simple, only two levels are used for our automatically generated circuits.

ECL families are also characterized by the maximum fanin of the *OR* terms. This number is determined by the noise margins, including factors such as IR drops and variable transistor characteristics. In our family the *OR* fanin limit is 10. Coupled with our 2-way current steering and a maximum of two levels of steering, the maximum fanin for a single ECL gate is 30. Figure 3 shows an ECL gate with a fanin of 30. All other gates we may wish to use can be constructed from

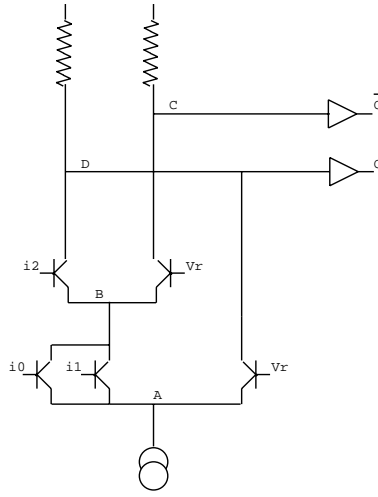

Figure 2: gate for $F = (i_0 + i_1)\overline{i_2}$

this gate by deleting inputs and connecting up the resistors differently. The top of each current path can be connected to either of the resistors (but not both). This gives us much flexibility in terms of the logic functions we can implement. When two current paths are connected to the same resistor, it effectively creates an *OR* of those paths.

We can describe this general gate using boolean logic. There are two sorts of parameters for this description. Phase constants, denoted ϕ_n , select among various wiring patterns and circuit forms. These cannot be changed once the gate is implemented. Input variables, denoted x_n , are inputs to the gate and of course change during gate operation. The general circuit form is:

$$F(x_0, \dots, x_{29}) = mux(S_x, \phi_y \oplus S_y, \phi_z \oplus S_z)$$

where

$$S_x = x_0 + \dots + x_9$$

$$S_y = x_{10} + \dots + x_{19}$$

$$S_z = x_{20} + \dots + x_{29}$$

and

$$mux(a, b, c) = a \cdot b + \overline{a} \cdot c$$

The ϕ constants are used to select the true or complement of each secondary *OR* term by choosing which resistors the current paths are connected to. Although not represented in this equation, \overline{F} is also available for the cost of an output driver.

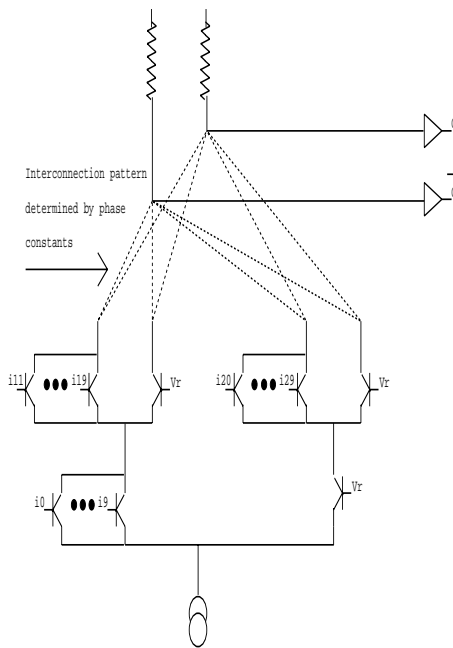

Figure 3: 30 input ECL gate

3 Previous Work

Technology mapping takes a network and maps it into a gate netlist. Part of the process carves out subnetworks and tries to map them to a gate. Two main approaches are used to do this mapping. Tree matching[3, 5] has been traditional, but current work is concentrated in the area of boolean matching[2]. Boolean matching looks not at the shape of a subnetwork, but rather at the logic function it implements. A gate is chosen based on this logic function, or failure is reported if no single gate can implement the function. The technology mapping algorithm repeatedly asks the boolean matcher to find possible covers of subnetworks, and uses these results to select a good cover for the entire network.

Another system[7] does technology mapping for ECL. That system, however, uses gates in a library rather than a general circuit form, restricting the quality of the output. We are unaware of any system that uses a boolean matching approach to map full-custom ECL gates.

In our technology there is one fully-populated gate from which all other gates can be derived by bridging and/or deleting inputs. Although previous work[2] can handle the deletion of inputs to create matches, that is not the right approach for us since we only have one gate form, and the number of possible bridges or deletions is large. Instead, we try to reshape the function in hand to

see if we can put it into our general gate form. This is much faster for two reasons: the complexity of our algorithm is less than other boolean matching algorithms, and our algorithm matches against a single circuit form rather than requiring a large number of matches against different circuit forms.

4 Matching Algorithm

In this section, we describe an efficient algorithm to check whether a Boolean function F can be decomposed to our full-custom ECL circuit form. We assume that all Boolean function manipulations are performed using Boolean Decision Diagrams (BDDs) [1].

4.1 Notation

Let (x_1, \dots, x_n) be n Boolean variables. Let X be a set of literals, i.e. a subset of $\{x_1, \overline{x_1}, x_2, \overline{x_2}, \dots, x_n, \overline{x_n}\}$.

In what follows we suppose that a set of literals never contains a variable and its negation.

- $s_X = \sum_{x \in X} x$ denotes the disjunction of all the literals contained in X . Its negation, $\overline{s_X}$, denotes the cube $\prod_{x \in X} \overline{x}$.
- $var(X)$ denotes the set of variables appearing in X . For example if $X = \{x_1, \overline{x_3}, x_5\}$ then $var(X) = \{x_1, x_3, x_5\}$.
- By extension, if x is a literal, $var(x)$ denotes the variable from which x is derived.
- $mux(a, b, c)$ denotes the Boolean function $a \cdot b + \overline{a} \cdot c$.
- $form(F)$ is a boolean predicate that is true if and only if F is a sum or a cube. When $form(F)$ is true, ϕ_F and X_F will denote respectively a Boolean constant and a set of literals that are such that $F = \phi_F \oplus s_{X_F}$.

4.2 Description of the Algorithm

The matching algorithm itself is simple. The main problem is to prove that it detects exactly the functions of the form $F(x_1, \dots, x_n) = mux(s_X, \phi_Y \oplus s_Y, \phi_Z \oplus s_Z)$. The difficulty resides in the fact that we cannot suppose that $var(X)$, $var(Y)$ and $var(Z)$ are mutually disjoint without limiting the expressive power of the decomposition.

Here is an example. Let $F(a, x, y, z_1, z_2) = ay + \overline{a}(x + z_1z_2)$. As written, F is not decomposed in the required form. However F can be rewritten as follows: $F(a, x, y, z_1, z_2) = mux(a + x, 0 \oplus (\overline{a} + y), 1 \oplus (\overline{z_1} + \overline{z_2}))$, which is an acceptable decomposition. F does not have any such decomposition for which the sets $var(X)$ and $var(Y)$ are disjoint.

Algorithm

Input: A Boolean function $F(x_1, \dots, x_n)$

Output: If it exists, a triplet (F_X, F_Y, F_Z) of boolean functions such that $F(x_1, \dots, x_n) = \text{mux}(F_X, F_Y, F_Z)$ where F_X is a sum of literals, $\text{form}(F_Y)$ is true and $\text{form}(F_Z)$ is true.

1. Compute the cofactor F_x for every literal x .
2. Group the literals by equivalence classes; two literals x and x' are considered to be equivalent if $F_x = F_{x'}$.
3. For every equivalence class X do:
 - (a) Let x be any element of the equivalence class X . Let F_Y be the Boolean function F_x . If $\text{form}(F_Y)$ is not true, skip to the next equivalence class.
 - (b) If $\text{form}(F_{\overline{s_X}})$ is true, return the result $(s_X, F_Y, F_{\overline{s_X}})$.
 - (c) Compute the set X' of literals v satisfying the following two properties: $\text{var}(v) \in \text{var}(F_Y)$ and $F_v = (F_Y)_v$.
 - (d) If $\text{form}(F_{\overline{s_{X \cup X'}}})$ is true, then return the result $(s_{X \cup X'}, F_Y, F_{\overline{s_{X \cup X'}}})$
4. For every literal x do:
 - (a) If $\text{form}(F_x)$ is not true, skip to the next literal.
 - (b) Repeat steps 3c and 3d with $X = \emptyset$ and $F_Y = \phi_{F_x} \oplus (\overline{x} + s_{X_{F_x}})$.
5. If all literals and equivalence classes have been processed without finding a solution, F cannot be decomposed as desired.

4.3 Time Complexity

The cofactor of a BDD by a literal has time complexity $O(N)$ where N is the number of BDD nodes. The most expensive step of the algorithm is step 3c, which may require up to $O(n^2)$ cofactor computations in total. The worst-case complexity of the algorithm is thus $O(n^2 \times N)$. We do not expect the worst-case complexity to be attained often. Equivalence classes and the test $\text{var}(v) \in \text{var}(F_Y)$ act as a filter, reducing the term $O(n^2)$. Moreover F_Y has $|X|$ fewer variables than F and is likely to have a smaller BDD representation.

4.4 Proof of Correctness

Lemma 4.1 *Let F and F_Y be two Boolean functions and X_0 a set of literals such that for each v in X_0 we have $F_v = (F_Y)_v$. Then $F = \text{mux}(s_{X_0}, F_Y, F_{\overline{s_{X_0}}})$.*

Proof Let $G = \text{mux}(s_{X_0}, F_Y, F_{\overline{s_{X_0}}})$. We only need to prove that $F = G$ when $s_{X_0} = 1$. Let v be a literal in X_0 . By hypothesis, we have: $F_v = (F_Y)_v$. On the other hand by definition of G we have $G_v = (F_Y)_v$. Thus for every literal in X_0 we have $F_v = G_v$ which proves that $F = G$. ■

Theorem 4.2 *Every solution found by the algorithm is a valid decomposition of F .*

Proof In step 3b, 3d and 4b of the algorithm, the pairs $(F_Y, X_0 = X)$, $(F_Y, X_0 = X \cup X')$ and $(F_Y, X_0 = X \cup X')$ satisfy the hypothesis of lemma 4.1. Moreover the decompositions are returned by the algorithm only if $\text{form}(F_Y)$ and $\text{form}(F_{\overline{s_{X_0}}})$ are both true. Thus the algorithm only returns valid decompositions of F . ■

Lemma 4.3 *Let F be such that $F = \text{mux}(s_X, F_Y, F_Z)$ and $\text{form}(F_Z)$ true. Let X_0 be a set of literals containing X and such that for every literal v in X_0 we have $F_v = (F_Y)_v$. Then $F = \text{mux}(s_{X_0}, F_Y, F_{\overline{s_{X_0}}})$ and $\text{form}(F_{\overline{s_{X_0}}})$ is true.*

Proof Lemma 4.1 implies that $F = \text{mux}(s_{X_0}, F_Y, F_{\overline{s_{X_0}}})$. Since X_0 contains X we have $F_{\overline{s_{X_0}}} = (F_Z)_{\overline{s_{X_0}}}$. By hypothesis F_Z is a cube or a sum; therefore the cofactor of F_Z by the cube $\overline{s_{X_0}}$ is also a cube or a sum, which proves that $\text{form}(F_{\overline{s_{X_0}}})$ is true. ■

Lemma 4.4 *Let F be such that $F = \text{mux}(s_X, F_Y, F_Z)$. Let $X_1 = \{v \in X, \text{var}(v) \notin \text{var}(F_Y)\}$ and $X_2 = \{v \in X, \text{var}(v) \in \text{var}(F_Y)\}$. Then the following assertions hold:*

- (i) if $X_1 \neq \emptyset$, X_1 is contained in a unique equivalence class X_{eq} .
- (ii) if $X' = \{v, \text{var}(v) \in \text{var}(F_Y) \text{ and } F_v = (F_Y)_v\}$ as in step 3d of the algorithm, then $X_2 \subseteq X'$.

Proof (i) Let v be an element of X_1 . Since $\text{var}(v)$ does not belong to $\text{var}(F_Y)$, we have $F_v = (F_Y)_v = F_Y$. Thus all cofactors of F by elements of X_1 are equal to the same function, F_Y , which proves that X_1 is a subset of an equivalence class. If X_1 is not empty, then this equivalence class is unique.

(ii) By definition, every element v of X_2 is such that $\text{var}(v) \in \text{var}(F_Y)$. Moreover since $X_2 \subseteq X$ we have $F_v = (F_Y)_v$ which proves that v belongs to X' . ■

Lemma 4.5 *Let $F = \text{mux}(s_X, F_Y, F_Z)$ be such that $\text{form}(F_Y)$ and $\text{form}(F_Z)$ are true. Let X_1, X_2 and X' be as in lemma 4.4. We suppose that $X_1 \neq \emptyset$. Let X_{eq} be the equivalence class containing X_1 and x an element of X_1 . Then $F_Y = F_x$ and when the algorithm is processing the equivalence class X_{eq} :*

- if $X_2 = \emptyset$ the algorithm returns the valid decomposition $\text{mux}(s_{X_{eq}}, F_x, F_{\overline{s_{X_{eq}}}})$ in step 3b.
- if $X_2 \neq \emptyset$ the algorithm returns the valid decomposition $\text{mux}(s_{X_{eq} \cup X'}, F_x, F_{\overline{s_{X_{eq} \cup X'}}})$ in step 3d.

Proof If $X_2 = \emptyset$, apply lemma 4.1 with $F_Y = F_x$ and $X_0 = X_{eq}$. If $X_2 \neq \emptyset$, apply lemma 4.1 with $F_Y = F_x$ and $X_0 = X_{eq} \cup X'$. Lemma 4.4 shows that in both cases $X \subseteq X_0$. Lemma 4.3 concludes the proof. ■

Lemma 4.6 *Let $F = mux(s_X, F_Y, F_Z)$ be such that $form(F_Y)$ and $form(F_Z)$ are true. Let X_1, X_2 and X' be as in lemma 4.4. We suppose that $X_1 = \emptyset$. If one exists, let x be an element of X_2 appearing in negated form in X_{F_Y} . Let X' be as in lemma 4.4. Then $F_Y = \phi_{F_x} \oplus (\bar{x} + s_{X_{F_x}})$ and when the algorithm processes the literal x in step 4b it returns the valid decomposition $mux(s_{X'}, \phi_{F_x} \oplus (\bar{x} + s_{X_{F_x}}), F_{\overline{s_{X'}}$.*

Proof We have $F_x = (F_Y)_x$. Since $form(F_Y)$ is true, $form(F_x)$ is also true. Thus $(F_Y)_x = F_x = \phi_{F_x} \oplus s_{X_{F_x}}$. By hypothesis, x appears in negated form in $s_{X_{F_Y}}$, thus $F_Y = \phi_{F_x} \oplus (\bar{x} + s_{X_{F_x}})$. From lemma 4.1, we deduce that $F = mux(s_{X'}, F_Y, F_{\overline{s_{X'}}$. Since $X_1 = \emptyset$, we have $X = X_2 \subseteq X'$. We conclude with lemma 4.3 that $form(F_{\overline{s_{X'}}$ is true. ■

Theorem 4.7 *If a solution exists, it is found and returned.*

Proof The only case not covered by the lemmas 4.5 and 4.6 is the case where $X_1 = \emptyset$ and all literals in X_2 appear in F_Y unnegated. However in that case $F_Y = \phi \oplus (s_X + s_Y)$ for some set of literals Y , which means that F_Y can be replaced by the constant $\bar{\phi}$ and $F = mux(s_X, \bar{\phi}, F_Z)$. This case is handled by step 3b of the algorithm. ■

5 Experimental Results

We have chosen three blocks of control equations from our current processor design. Characteristics of these three blocks are shown in Table 1. The first block is the major control block in our design, controlling the integer and floating point datapaths. The other two are small blocks typical of the rest of the design.

Table 2 shows the results of mapping. Most gates are small, with fanins of 5 or less. Much of this is the result of small equations in the original design specification. Many equations are simple, in that they combine only a few variables or just pass data from one pipe stage to the next. Timing verification has shown us, however, that the critical path of the design contains more complex logic, so it is important that our mapping algorithm find good solutions. It is worth noting that the maximum fanin of the gates produced by our algorithm is relatively high.

circuit	# eqns	# lits	lit/eqn
Control	2319	9834	4.2
FPACtl	71	141	1.99
FPDivCtl	43	86	2.0

Table 1: Examples Used

circuit	# gates	gate/eqn	fanin	max fanin
Control	3534	1.53	2.89	22
FPACtl	71	1.00	2.06	8
FPDivCtl	43	1.00	2.05	5

Table 2: Performance of Full Algorithm

circuit	# gates	gate/eqn	fanin	max fanin	time
Control	3575	1.54	2.87	22	0.98
FPACtl	73	1.03	2.01	8	1.04
FPDivCtl	43	1.00	2.05	5	1.02

Table 3: Eliminating Steps 3d and 4

circuit	# gates	gate/eqn	fanin	max fanin	time
Control	5773	2.50	2.16	5	1.15
FPACtl	92	1.30	1.80	5	1.50
FPDivCtl	43	1.00	2.05	5	0.99

Table 4: Limited Mapping

eqns: number of equations in the circuit
lits: number of uses of literals in factored form
lit/eqn: average number of literals per equation
gates: number of gates produced by the algorithm
gate/eqn: average number of gates per equation
fanin: average gate fanin
max fanin: maximum gate fanin
time: ratio of runtime to full algorithm

We experimented with two variants of the algorithm, based on observation of the algorithm’s behavior on our three examples. We observed that 98.6% of the solutions found were found in step 3b of the algorithm, and all the remaining solutions were found in step 3d. Step 4 was not needed for any of our examples, although we can construct artificial examples that do require step 4.

Based upon this data, we tried eliminating steps 3c, 3d and 4 from our algorithm. Table 3 shows the results. CPU time is essentially unchanged, while the number of gates needed has gone up slightly. It is important to note that when the algorithm misses a match, the algorithm will be called again on a smaller piece of logic. Thus, matching is tried over and over on different pieces until a match is found. A faster algorithm that misses matches can actually result in longer run times and poorer results.

Another variant we tried was to limit the mapped functions to $F = mux(F_x, F_y, F_z)$, where F_x , F_y , and F_z have disjoint support sets. In this case, we know that the function’s variables partition into no more than six equivalence classes. We combine steps 1 and 2 of the algorithm, computing equivalence classes as we go. We can terminate our computation early if more than 6 are found. In addition, in step 3 we pick the equivalence class with the most members, rather than iterating over all equivalence classes. This results in an algorithm that terminates early on complicated cases. Table 4 shows that this is a poor choice. The algorithm misses so many matches that the total runtime increases and the results become poorer.

6 Conclusion and Future Work

We have demonstrated a technology mapper for full-custom ECL gates. The technology mapper takes advantage of the high fanin and regular structure of these gates to implement each equation using a small number of gates. The algorithm proceeds using efficient operations on BDDs, producing a mapping in an acceptable amount of time.

Not described in this paper are electrical optimizations on the gates produced. These optimizations include separate power sizing of the logic portion of the gate and the output driver. This power sizing is done by starting with low power everywhere, and then walking over the graph of gates and wires increasing the power along the critical path. Trial placements of the gates are done in order to estimate capacitance, which is taken into

account during the power adjustment phase. Additional optimizations change voltage swings and convert signals to differential pairs when it is possible given the choice of gates. Certain gates, such as those with a large number of *OR* terms at the bottom, can be best implemented using a slightly different circuit called a level-shifting-OR, so we have a pattern matching and replacement phase to take care of this and similar optimizations.

Future extensions to the mapper described here could look at a number of factors. The delay through an ECL gate is not the same for each input, so it makes a difference to which input a variable is assigned. In order to take this into account in our algorithm, we would have to have available the arrival times of the individual inputs and a model for gate delay.

7 Acknowledgments

We would like to thank Hamid Savoj for his help, as well as Jeremy Dion, Ramsey Haddad, and Louis Monier of Digital Equipment Corporation's Western Research Laboratory. In addition, Ramsey Haddad deserves credit for the initial implementation of our BDD package.

References

- [1] R. E. Bryant. Graph Based Algorithms for Boolean Function Manipulation. *IEEE Transactions on Computers*, C-35(8):677–691, August 1986.
- [2] J. R. Burch and D. E. Long. Efficient Boolean Function Mapping. In *Proc. of the ICCAD-92*, pages 408–411, November 1992.
- [3] E. Detjens, G. Gannot, R. Rudell, A. Sangiovanni-Vincentelli, and A. Wang. Technology Mapping in MIS. In *Proc. of the ICCAD-87*, pages 116–119, November 1987.
- [4] N. Jouppi, P. Boyle, J. Dion, J. Doherty, A. Eustace, R. Haddad, R. Mayo, S. Menon, L. Monier, D. Stark, S. Turrini, and L. Yang. A 300MHz 115W 32b Bipolar ECL Microprocessor with On-Chip Caches. In *IEEE International Solid-State Circuits Conference*, February 1993.
- [5] K. Keutzer. DAGON: Technology Binding and Local Optimization by DAG Matching. In *Proceedings of the 24th Design Automation Conference*, pages 341–347. ACM/IEEE, June 1987.
- [6] L. Monier and J. Dion. Design Tools for BIPS-0. Technical Report TN-32, Digital Equipment Corporation. Western Research Laboratory, December 1992.
- [7] V. Morgan and D. Gregory. An ECL Logic-Synthesis System. In *28st ACM/IEEE Design Automation Conference*, pages 106–111, 1991.

WRL Research Reports

“Titan System Manual.”

Michael J. K. Nielsen.

WRL Research Report 86/1, September 1986.

“Global Register Allocation at Link Time.”

David W. Wall.

WRL Research Report 86/3, October 1986.

“Optimal Finned Heat Sinks.”

William R. Hamburguen.

WRL Research Report 86/4, October 1986.

“The Mahler Experience: Using an Intermediate Language as the Machine Description.”

David W. Wall and Michael L. Powell.

WRL Research Report 87/1, August 1987.

“The Packet Filter: An Efficient Mechanism for User-level Network Code.”

Jeffrey C. Mogul, Richard F. Rashid, Michael J. Accetta.

WRL Research Report 87/2, November 1987.

“Fragmentation Considered Harmful.”

Christopher A. Kent, Jeffrey C. Mogul.

WRL Research Report 87/3, December 1987.

“Cache Coherence in Distributed Systems.”

Christopher A. Kent.

WRL Research Report 87/4, December 1987.

“Register Windows vs. Register Allocation.”

David W. Wall.

WRL Research Report 87/5, December 1987.

“Editing Graphical Objects Using Procedural Representations.”

Paul J. Asente.

WRL Research Report 87/6, November 1987.

“The USENET Cookbook: an Experiment in Electronic Publication.”

Brian K. Reid.

WRL Research Report 87/7, December 1987.

“MultiTitan: Four Architecture Papers.”

Norman P. Jouppi, Jeremy Dion, David Boggs, Michael J. K. Nielsen.

WRL Research Report 87/8, April 1988.

“Fast Printed Circuit Board Routing.”

Jeremy Dion.

WRL Research Report 88/1, March 1988.

“Compacting Garbage Collection with Ambiguous Roots.”

Joel F. Bartlett.

WRL Research Report 88/2, February 1988.

“The Experimental Literature of The Internet: An Annotated Bibliography.”

Jeffrey C. Mogul.

WRL Research Report 88/3, August 1988.

“Measured Capacity of an Ethernet: Myths and Reality.”

David R. Boggs, Jeffrey C. Mogul, Christopher A. Kent.

WRL Research Report 88/4, September 1988.

“Visa Protocols for Controlling Inter-Organizational Datagram Flow: Extended Description.”

Deborah Estrin, Jeffrey C. Mogul, Gene Tsudik, Kamaljit Anand.

WRL Research Report 88/5, December 1988.

“SCHEME->C A Portable Scheme-to-C Compiler.”

Joel F. Bartlett.

WRL Research Report 89/1, January 1989.

“Optimal Group Distribution in Carry-Skip Ad-ders.”

Silvio Turrini.

WRL Research Report 89/2, February 1989.

“Precise Robotic Paste Dot Dispensing.”

William R. Hamburguen.

WRL Research Report 89/3, February 1989.

“Simple and Flexible Datagram Access Controls for Unix-based Gateways.”

Jeffrey C. Mogul.

WRL Research Report 89/4, March 1989.

“Spritely NFS: Implementation and Performance of Cache-Consistency Protocols.”

V. Srinivasan and Jeffrey C. Mogul.

WRL Research Report 89/5, May 1989.

“Available Instruction-Level Parallelism for Superscalar and Superpipelined Machines.”

Norman P. Jouppi and David W. Wall.

WRL Research Report 89/7, July 1989.

“A Unified Vector/Scalar Floating-Point Architecture.”

Norman P. Jouppi, Jonathan Bertoni, and David W. Wall.

WRL Research Report 89/8, July 1989.

“Architectural and Organizational Tradeoffs in the Design of the MultiTitan CPU.”

Norman P. Jouppi.

WRL Research Report 89/9, July 1989.

“Integration and Packaging Plateaus of Processor Performance.”

Norman P. Jouppi.

WRL Research Report 89/10, July 1989.

“A 20-MIPS Sustained 32-bit CMOS Microprocessor with High Ratio of Sustained to Peak Performance.”

Norman P. Jouppi and Jeffrey Y. F. Tang.

WRL Research Report 89/11, July 1989.

“The Distribution of Instruction-Level and Machine Parallelism and Its Effect on Performance.”

Norman P. Jouppi.

WRL Research Report 89/13, July 1989.

“Long Address Traces from RISC Machines: Generation and Analysis.”

Anita Borg, R.E.Kessler, Georgia Lazana, and David W. Wall.

WRL Research Report 89/14, September 1989.

“Link-Time Code Modification.”

David W. Wall.

WRL Research Report 89/17, September 1989.

“Noise Issues in the ECL Circuit Family.”

Jeffrey Y.F. Tang and J. Leon Yang.

WRL Research Report 90/1, January 1990.

“Efficient Generation of Test Patterns Using Boolean Satisfiability.”

Tracy Larrabee.

WRL Research Report 90/2, February 1990.

“Two Papers on Test Pattern Generation.”

Tracy Larrabee.

WRL Research Report 90/3, March 1990.

“Virtual Memory vs. The File System.”

Michael N. Nelson.

WRL Research Report 90/4, March 1990.

“Efficient Use of Workstations for Passive Monitoring of Local Area Networks.”

Jeffrey C. Mogul.

WRL Research Report 90/5, July 1990.

“A One-Dimensional Thermal Model for the VAX 9000 Multi Chip Units.”

John S. Fitch.

WRL Research Report 90/6, July 1990.

“1990 DECWRL/Livermore Magic Release.”

Robert N. Mayo, Michael H. Arnold, Walter S. Scott, Don Stark, Gordon T. Hamachi.

WRL Research Report 90/7, September 1990.

“Pool Boiling Enhancement Techniques for Water at Low Pressure.”

Wade R. McGillis, John S. Fitch, William R. Hambrun, Van P. Carey.

WRL Research Report 90/9, December 1990.

“Writing Fast X Servers for Dumb Color Frame Buffers.”

Joel McCormack.

WRL Research Report 91/1, February 1991.

- “A Simulation Based Study of TLB Performance.”
J. Bradley Chen, Anita Borg, Norman P. Jouppi.
WRL Research Report 91/2, November 1991.
- “Analysis of Power Supply Networks in VLSI Circuits.”
Don Stark.
WRL Research Report 91/3, April 1991.
- “TurboChannel T1 Adapter.”
David Boggs.
WRL Research Report 91/4, April 1991.
- “Procedure Merging with Instruction Caches.”
Scott McFarling.
WRL Research Report 91/5, March 1991.
- “Don’t Fidget with Widgets, Draw!”
Joel Bartlett.
WRL Research Report 91/6, May 1991.
- “Pool Boiling on Small Heat Dissipating Elements in Water at Subatmospheric Pressure.”
Wade R. McGillis, John S. Fitch, William R. Hamburgren, Van P. Carey.
WRL Research Report 91/7, June 1991.
- “Incremental, Generational Mostly-Copying Garbage Collection in Uncooperative Environments.”
G. May Yip.
WRL Research Report 91/8, June 1991.
- “Interleaved Fin Thermal Connectors for Multichip Modules.”
William R. Hamburgren.
WRL Research Report 91/9, August 1991.
- “Experience with a Software-defined Machine Architecture.”
David W. Wall.
WRL Research Report 91/10, August 1991.
- “Network Locality at the Scale of Processes.”
Jeffrey C. Mogul.
WRL Research Report 91/11, November 1991.
- “Cache Write Policies and Performance.”
Norman P. Jouppi.
WRL Research Report 91/12, December 1991.
- “Packaging a 150 W Bipolar ECL Microprocessor.”
William R. Hamburgren, John S. Fitch.
WRL Research Report 92/1, March 1992.
- “Observing TCP Dynamics in Real Networks.”
Jeffrey C. Mogul.
WRL Research Report 92/2, April 1992.
- “Systems for Late Code Modification.”
David W. Wall.
WRL Research Report 92/3, May 1992.
- “Piecewise Linear Models for Switch-Level Simulation.”
Russell Kao.
WRL Research Report 92/5, September 1992.
- “A Practical System for Intermodule Code Optimization at Link-Time.”
Amitabh Srivastava and David W. Wall.
WRL Research Report 92/6, December 1992.
- “A Smart Frame Buffer.”
Joel McCormack & Bob McNamara.
WRL Research Report 93/1, January 1993.
- “Recovery in Spritely NFS.”
Jeffrey C. Mogul.
WRL Research Report 93/2, June 1993.
- “Tradeoffs in Two-Level On-Chip Caching.”
Norman P. Jouppi & Steven J.E. Wilton.
WRL Research Report 93/3, October 1993.
- “Unreachable Procedures in Object-oriented Programming.”
Amitabh Srivastava.
WRL Research Report 93/4, August 1993.
- “Limits of Instruction-Level Parallelism.”
David W. Wall.
WRL Research Report 93/6, November 1993.

“Fluoroelastomer Pressure Pad Design for Microelectronic Applications.”

Alberto Makino, William R. Hamburg, John S. Fitch.

WRL Research Report 93/7, November 1993.

WRL Technical Notes

“TCP/IP PrintServer: Print Server Protocol.”

Brian K. Reid and Christopher A. Kent.

WRL Technical Note TN-4, September 1988.

“TCP/IP PrintServer: Server Architecture and Implementation.”

Christopher A. Kent.

WRL Technical Note TN-7, November 1988.

“Smart Code, Stupid Memory: A Fast X Server for a Dumb Color Frame Buffer.”

Joel McCormack.

WRL Technical Note TN-9, September 1989.

“Why Aren’t Operating Systems Getting Faster As Fast As Hardware?”

John Ousterhout.

WRL Technical Note TN-11, October 1989.

“Mostly-Copying Garbage Collection Picks Up Generations and C++.”

Joel F. Bartlett.

WRL Technical Note TN-12, October 1989.

“The Effect of Context Switches on Cache Performance.”

Jeffrey C. Mogul and Anita Borg.

WRL Technical Note TN-16, December 1990.

“MTOOL: A Method For Detecting Memory Bottlenecks.”

Aaron Goldberg and John Hennessy.

WRL Technical Note TN-17, December 1990.

“Predicting Program Behavior Using Real or Estimated Profiles.”

David W. Wall.

WRL Technical Note TN-18, December 1990.

“Cache Replacement with Dynamic Exclusion”

Scott McFarling.

WRL Technical Note TN-22, November 1991.

“Boiling Binary Mixtures at Subatmospheric Pressures”

Wade R. McGillis, John S. Fitch, William R. Hamburg, Van P. Carey.

WRL Technical Note TN-23, January 1992.

“A Comparison of Acoustic and Infrared Inspection Techniques for Die Attach”

John S. Fitch.

WRL Technical Note TN-24, January 1992.

“TurboChannel Versatec Adapter”

David Boggs.

WRL Technical Note TN-26, January 1992.

“A Recovery Protocol For Spritely NFS”

Jeffrey C. Mogul.

WRL Technical Note TN-27, April 1992.

“Electrical Evaluation Of The BIPS-0 Package”

Patrick D. Boyle.

WRL Technical Note TN-29, July 1992.

“Transparent Controls for Interactive Graphics”

Joel F. Bartlett.

WRL Technical Note TN-30, July 1992.

“Design Tools for BIPS-0”

Jeremy Dion & Louis Monier.

WRL Technical Note TN-32, December 1992.

“Link-Time Optimization of Address Calculation on
a 64-Bit Architecture”

Amitabh Srivastava and David W. Wall.

WRL Technical Note TN-35, June 1993.

“Combining Branch Predictors”

Scott McFarling.

WRL Technical Note TN-36, June 1993.

“Boolean Matching for Full-Custom ECL Gates”

Robert N. Mayo and Herve Touati.

WRL Technical Note TN-37, June 1993.