

10BaseS™ Ethernet Modem

Easy Start

Version 1.0

Contents

About this Easy Start	2
Safety Guidelines	2
Minimum System Requirements	2
Package.....	2
Front Indicators	3
Step 1: Connecting the Modem to Your Computer/Notebook ...	4
Step 2: Configuring Your Ethernet Card	7
Step 3: Configuring Your Internet Browser	9
Step 4: Connecting to the Internet	10

- Product warranty does not apply to damage caused by lightning, power surges or wrong voltage usage.
- 10BaseS™ is the trademark of Infineon Technologies AG.
- All other company or product names are trademarks or registered trademarks or service marks of their respective owners.

About this Easy Start

This booklet contains information on setting up your 10BaseS™ Ethernet Modem. It touches on the key installation procedures to help you setup your Modem.

Safety Guidelines

- Understand all instructions in the manual. Follow all instruction labels found on the unit.
- Keep the modem away from fluid, direct sunlight and excessive heat.
- During times of lightning strike/thunderstorm, do not use the modem.
- To reduce risk of fire, use only No.26 AWG or larger telecommunication line cord.

Minimum System Requirements

- Pentium® MMX 233MHz (or above)
- An Ethernet card installed with TCP/IP Protocol on your computer
- OS Independent

Package

For any missing items, please contact your dealer immediately.

1 Ethernet Modem



2 Easy Start



3 Telephone cable (RJ-11)²



4 Straight CAT-5 UTP Ethernet cable (RJ-45)



5 Power adapter



¹ The telephone extension cable used for this modem is a UL Listed Communication Circuit Accessory, minimum 26AWG.

Front Indicators



① **Ethernet**

Lights up when the Ethernet connection is established.

② **DSL**

Lights up when the 10BaseS™ connection is established.

③ **POWER**

Lights up when you have connected the Modem to the Power Outlet via the power adapter that comes with your modem package.

Step 1: Connecting the Modem to Your Computer/Notebook



Power off your Computer/Notebook or/and any connected devices before connecting to the Modem!

To connect your Computer/Notebook to your modem, you need to have an **Ethernet Port** present on your Computer/Notebook.

Step 1.1 Connecting to the Ethernet



NOT SURE HOW THE ETHERNET PORT LOOKS LIKE?

The following are some tips to help you locate your Ethernet Port on your Computer/Notebook. Alternatively, you may refer to the documentation that comes with your Computer/Notebook.

Most Computers/Notebooks have labels describing the Ports. For Ethernet Port, you will see either **ETHERNET**, **ETH** or **RJ45** labelled near the Port.

If your Computer/Notebook does not have such descriptions, try the following.

- **Picture A** gives the illustration of an Ethernet Port. All Ethernet Ports have **8** conductors on it. Do not mistaken with the LINE Port (Picture B) that has only 6 conductors.

- The Ethernet Port is slightly bigger than the LINE Port.

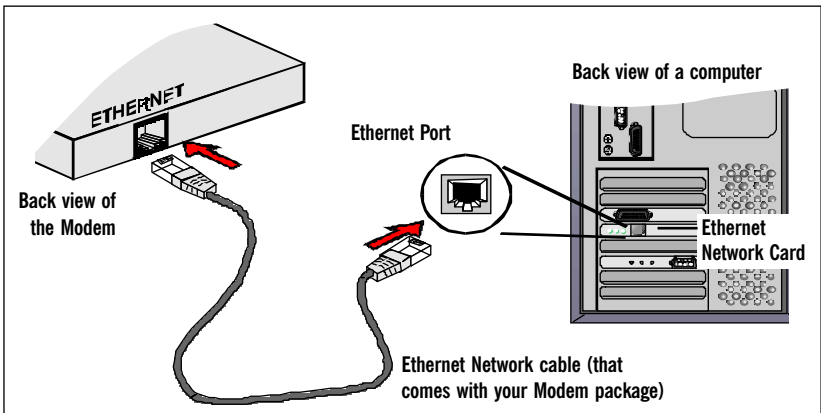
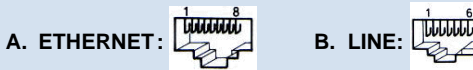

Step 1.2 Connecting to the Telephone Wall Socket

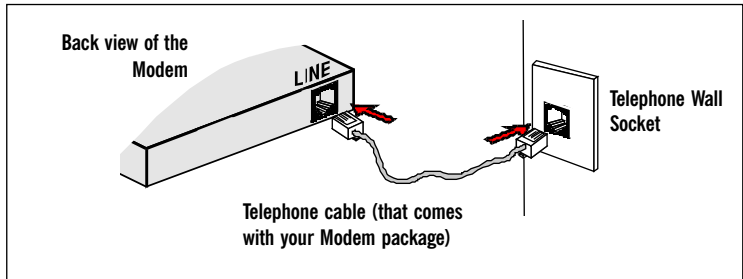

Step 1.3 Connecting to the Telephone Set (optional)

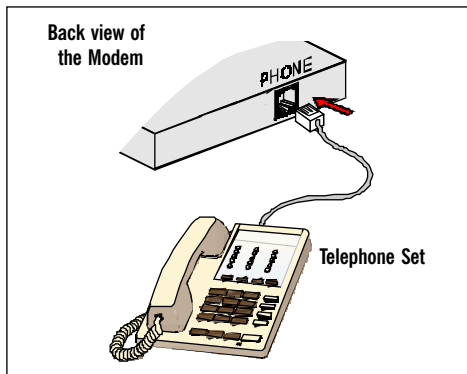

Step 1.4 Connecting to the Power Outlet

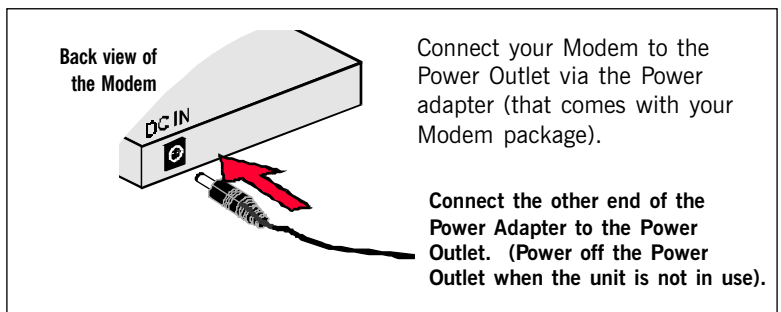

Step 1.5 Checking Your Connections

Please check your connections before proceeding.

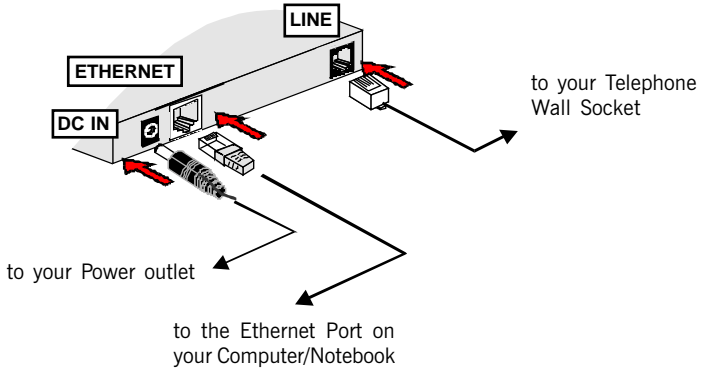

Step 1.6 Powering On

- Power on the Power Outlet that the Modem is connected to.
- Power on your Computer(s)/Notebook(s).

Please proceed to [Step 2](#).

Step 2: Configuring Your Ethernet Card



The following illustrated screen shots serve only as examples. For any dissimilarities, please follow closely to the instructions prompted on your Computer.

2.1 For Windows® 98 Second Edition / Windows® Me

- i From your Windows desktop, right-click on the **Network Neighborhood** icon. Select **Properties**.
- ii From the **Configuration** tab, select **TCP/IP-> xxx** where **xxx** refers to the model of your **Ethernet Card** that is connected to your Modem.
Click **Properties**.

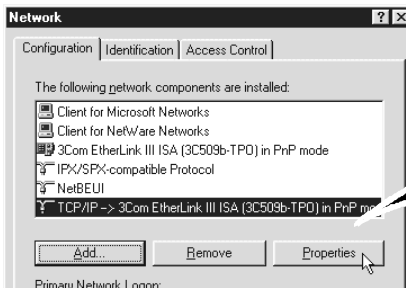

(3Com EtherLink III ISA Ethernet card model is used as an example here. You should see the model of your Ethernet card).

- iii Select the **IP Address** tab.
Click the option **Specify an IP address**.
Enter the **IP Address** and **Subnet Mask** as specified by your Service Provider.
Click **OK** and restart your system when prompted.
You may now proceed to **Step 3**.

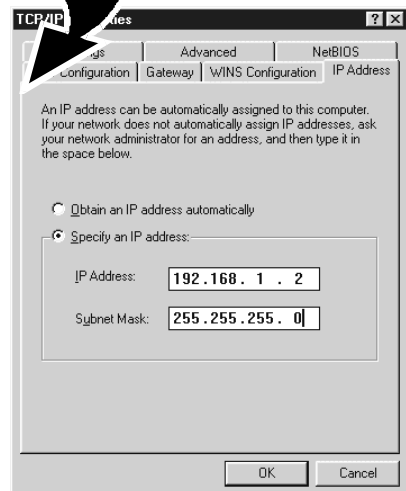

2.2 For Windows® 2000 / Windows® XP

i **Windows® 2000:**

- a) From your Windows desktop, right-click on the icon **My Network Places** and select **Properties**.
- b) At the **Network and Dial-up Connections** window, right-click on the **Local Area Connection** icon and select **Properties**.

Windows® XP:

(Instructions are based on default **Start menu** option)

- a) From your Windows desktop, click **Start** > **All Programs** > **Accessories** > **Communications** > **Network Connections**.
 - b) Right-click on the **Local Area Connection** icon that reflects **the model of your Ethernet Card that is connected to your Modem** and click **Properties**.
- ii Ensure that the field **Connect Using** indicates the model of your Ethernet Card that is connected to your Modem.

(This is important especially if you have more than one **Local Area Connection** icons displayed at the **Network and Dial-up Connections** / **Network Connections** window. Ensure that you have selected the correct one.)

Select **Internet Protocol (TCP/IP)** and click **Properties**.

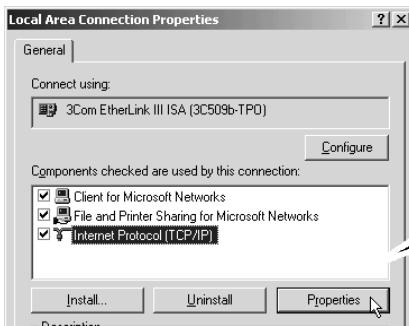

(3Com EtherLink III ISA Ethernet card model is used as an example here. You should see the model of your Ethernet card).

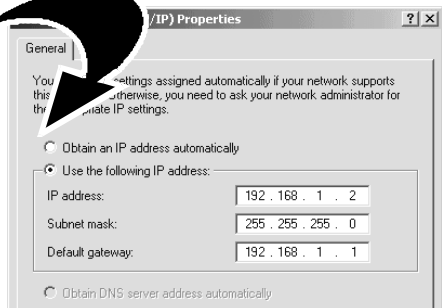

- iii Select the option Use the following IP address.

Enter the **IP Address**, **Subnet Mask** and **Default gateway** as specified by your Service Provider.

Click **OK** to close.

You may now proceed to **Step 3**.

Step 3: Configuring Your Internet Browser

3.1 Microsoft® Internet Explorer™ (based on IE 5.5)

- i From your Windows desktop, double-click on your Internet Explorer icon  to launch your Browser.
- ii From the Menu, click **Tools** and select **Internet Options...**
- iii Select the **Connection** tab. Click the field, '**Never dial a connection**'. (This option will be grayed off if you have not installed an analog modem on your computer/notebook before. Proceed with **3.1 iv**).
- iv Click the **LAN Settings...** button. Ensure that your **Proxy Server** is not enabled.
- v Click **OK** to close the dialog box.

You may now proceed to **Step 4**.

3.2 Netscape® Navigator

- i From your Windows desktop, double-click on your Navigator icon  to launch your Browser.
- ii Depending on your Netscape versions, carry out one of the following instructions:
Click **Options > Network Preferences**.
Select **Proxies**. Ensure that the **No Proxies** option is selected.
OR
Click **Edit > Preferences**.
Select **Advanced** and click **Proxies**. Ensure that the option **Direct Connection to the Internet** is enabled.
- iii Click **OK** for changes to take effect.

You may now proceed to **Step 4**.

Step 4: Connecting to the Internet

- i Check the front indicators of your Modem. If all the three indicators light up, it means that you are now connected to your Internet Service Provider.
- ii You may start surfing the Internet now!