

User's Guide

PowerDomain 2940UW/3940UW

Fast and Wide UltraSCSI Accelerator

PowerDomain 2940UW/3940UW User's Guide
Stock Number: 510864-00, Rev. B Page: Front Cover
Print Spec Number: 493742-00
Current Date: 2/20/96 ECN Date: 2/27/96

Adaptec, Inc.
691 South Milpitas Boulevard
Milpitas, CA 95035

Copyright © 1996, Adaptec, Inc.
All rights reserved. Adaptec and the
Adaptec logo are trademarks of Adaptec,
Inc. which may be registered in some
jurisdictions.

Printed in Singapore
STOCK NO.: 510864-00, Rev. B CW 2/96

PowerDomain 2940UW/3940UW User's Guide
Stock Number: 510864-00, Rev. B Page: Back Cover
Print Spec Number: 493742-00
Current Date: 2/20/96 ECN Date: 2/27/96

▼▼▼▼ **PowerDomain 2940UW**
/3940UW
Fast and Wide UltraSCSI Accelerator

User's Guide



Copyright

Copyright © 1996 Adaptec, Inc. All rights reserved. No part of this publication may be reproduced, stored in a retrieval system, or transmitted in any form or by any means, electronic, mechanical, photocopying, recording or otherwise, without the prior written consent of Adaptec, Inc., 691 South Milpitas Blvd., Milpitas, CA 95035.

Trademarks

Adaptec, the Adaptec logo, and PowerDomain are trademarks of Adaptec, Inc., which may be registered in some jurisdictions.

All other trademarks used are owned by their respective owners.

Changes

The material in this document is for information only and is subject to change without notice. While reasonable efforts have been made in the preparation of this document to assure its accuracy, Adaptec, Inc. assumes no liability resulting from errors or omissions in this document, or from the use of the information contained herein.

Adaptec reserves the right to make changes in the product design without reservation and without notification to its users.

Adaptec Technical Support and Services

If you have questions about installing or using the PowerDomain 2940UW/3940UW, check this document first—you will find answers to most of your questions here. If you need further assistance, please contact us. We offer the following support and information services:

- For technical support, for information about the Adaptec World Wide Web (WWW) and File Transfer Protocol (FTP) Servers and the Adaptec USA Bulletin Board Service (BBS), and for access to the Interactive Fax system, call 800-959-SCSI (7274) or 408-945-2550, 24 hours a day, 7 days a week. To speak with a product support representative, call 408-934-SCSI (7274), Monday through Friday, 6:00 A.M. to 5:00 P.M., Pacific Time; after these hours, on weekends, and on holidays, product support is also available for a fee at 800-416-8066.
 - The Adaptec WWW and FTP Servers provide product literature, answers to commonly asked questions, and information on software upgrades and other topics. The WWW and FTP Servers are available from the Internet 24 hours a day, 7 days a week, at <http://www.adaptec.com> and <ftp.adaptec.com>.
 - The Adaptec BBS provides answers to commonly asked questions and information on software upgrades and other topics. The BBS is available 24 hours a day, 7 days a week, at 408-945-7727; 1200/2400/9600/14,400/28,800 bps, 8 data bits, 1 stop bit, no parity.

- The Adaptec Interactive Fax system provides product literature, answers to commonly asked questions, and current information about Adaptec products and services. The Adaptec Interactive Fax system is available 23 hours a day, 7 days a week. The Fax system is out of service 1 hour each day. You can call this service directly at 408-957-7150.
- For sales information, call 800-959-SCSI (7274) or 408-945-2550, Monday through Friday, 6:00 A.M. to 5:00 P.M., Pacific Time.
- To order Adaptec software and cables, call 800-442-SCSI (7274) or 408-957-SCSI (7274), Monday through Friday, 6:00 A.M. to 5:00 P.M., Pacific Time.
- To request additional documentation for Adaptec products, call 800-934-2766 or 510-732-3829, Monday through Friday, 6:00 A.M. to 5:00 P.M., Pacific Time.

FCC Compliance Statement

This equipment has been tested and found to comply with the limits for a Class B digital device, pursuant to Part 15 of the FCC rules. These limits are designed to provide reasonable protection against harmful interference in residential installations. This equipment generates, uses, and can radiate radio frequency energy, and if not installed and used in accordance with the instructions, may cause harmful interference to radio communications. However, there is no guarantee that interference will not occur in a particular installation.

If this equipment does cause interference to radio or television equipment reception, which can be determined by turning the equipment off and on, the user is encouraged to try to correct the interference by one or more of the following measures:

- Reorient or relocate the receiving antenna
- Move the equipment away from the receiver
- Plug the equipment into an outlet on a circuit different from that to which the receiver is powered
- If necessary, the user should consult the dealer or an experienced radio/television technician for additional suggestions

CAUTION: Only equipment certified to comply with Class B (computer input/output devices, terminals, printers, etc.) should be attached to this equipment, and must have shielded interface cables.

Finally, any changes or modifications to the equipment by the user not expressly approved by the grantee or manufacturer could void the user's authority to operate such equipment.

Each PowerDomain 2940UW/3940UW is equipped with an FCC compliance label which shows only the FCC identification number. The full text of the associated label follows:

This device complies with part 15 of the FCC rules. Operation is subject to the following two conditions: (1) this device may not cause harmful interference and (2) this device must accept any interference received, including interference that may cause undesired operation.

▼▼▼▼ Contents

1 Getting Started

System Requirements **1-1**

 Hardware **1-1**

 Software **1-1**

Tools and Equipment Required **1-2**

Notes, Cautions, and Warnings **1-2**

2 Installing the PowerDomain 2940UW/ 3940UW and Connecting SCSI Devices

Installing the PowerDomain 2940UW/3940UW—
Tower Models **2-2**

Installing the PowerDomain 2940UW/3940UW—
Desktop Models **2-11**

Connecting SCSI Cables and Devices **2-19**

 Choosing SCSI Cables **2-21**

 Connecting Internal SCSI Devices **2-22**

 Connecting External SCSI Devices—Tower
 Models **2-34**

 Connecting External SCSI Devices—Desktop
 Models **2-41**

Setting SCSI Chain Termination **2-48**

 Setting SCSI Device Termination **2-49**

 Setting Accelerator Card Termination **2-49**

 Termination Examples **2-49**

Setting SCSI IDs **2-54**

Installing Multiple PowerDomain 2940UW/3940UW
Accelerator Cards **2-54**

v

3 Opening and Using the PowerDomain Control Utility

- Opening the PowerDomain Control Utility **3-2**
- Using the PowerDomain Control Utility **3-3**
 - Obtaining Additional SCSI Controller Information **3-4**
 - Setting Termination **3-7**
 - Updating Flash ROM **3-11**
 - Setting Advanced Options **3-14**
 - Setting Defaults **3-15**
 - Target Options **3-16**
- Saving Settings **3-20**
 - Target Options Dialog Box **3-20**
 - PowerDomain Control Window **3-21**
- Using Balloon Help **3-22**
- Getting Information about the PowerDomain Control Utility **3-22**
- Quitting the PowerDomain Control Utility **3-23**

4 Troubleshooting

- SCSI Troubleshooting Checklist **4-1**
- Error Messages **4-3**

A Product Specifications

- System Interface **A-1**
- Unit Connectivity (Single-ended) **A-1**
 - PowerDomain 2940UW **A-1**
 - PowerDomain 3940UW **A-1**
- Speed **A-2**
- Dimensions (Standard PCI Bus Form Factor) **A-2**
- Operating Environment **A-2**
- Power Requirement **A-2**

Index



Getting Started

Welcome to Adaptec[®], and congratulations on your purchase of the PowerDomain[™] 2940UW/3940UW. Your new SCSI (Small Computer System Interface) accelerator card features

- Fast, reliable data transfer among the SCSI devices connected to it
- A configuration control utility that enables you to easily change SCSI-related settings directly from your desktop

System Requirements

You must have the following hardware and software to use the PowerDomain 2940UW/3940UW.

Hardware

- MacOS PCI-based (peripheral component interconnect) computer
- 8 MB RAM (random-access memory)
- At least one free PCI expansion slot

Software

MacOS version 7.5.2 or later

Tools and Equipment Required

To install the PowerDomain 2940UW/3940UW, you should have the following items on hand:

- At least one PowerDomain 2940UW/3940UW accelerator card
- The *PowerDomain Control Utility* diskette included with your accelerator card
- A medium-sized standard screwdriver
- A wrist grounding strap (optional)

Notes, Cautions, and Warnings

Always use care when handling any electrical equipment. To avoid injury to people or damage to equipment and data, be sure to follow the cautions and warnings in this document.



Note: Notes are reminders, tips, or suggestions that might simplify the procedures included in this document.



Caution: Cautions alert you to actions that might cause damage to your system or your data.



WARNING: Warnings alert you to actions that might cause injury to you or someone else.

Adaptec does not claim to have included in this document every condition or situation that might require a caution or warning notice. Be sure to consult the documentation for your computer and any connected equipment when you are installing the equipment or changing its configuration.



WARNING: *Always* use caution when handling electrical equipment!



... 2

Installing the PowerDomain 2940UW/ 3940UW and Connecting SCSI Devices

This chapter tells you how to do the following:

- Install PowerDomain 2940UW/3940UW accelerator cards in your MacOS PCI-based system (both tower and desktop models)
- Connect internal and external SCSI devices to each PowerDomain 2940UW/3940UW installed
- Set SCSI chain termination
- Assign SCSI IDs

Installing the PowerDomain 2940UW/ 3940UW—Tower Models



Note: If your tower model differs from the one illustrated in this manual, refer to your computer user documentation for instructions on installing an expansion card. (Instructions for desktop models begin on page 2-11.)

To install the PowerDomain 2940UW/3940UW in your tower-model computer

- 1 Turn **OFF** the power to the computer and any attached devices, and disconnect all power cords.



WARNING: To avoid possible exposure to electric shock, be sure all power to your system is turned **OFF**.

- 2 Press the computer's power button. This will dissipate the charge in the power supply capacitors.

Installing the PowerDomain 2940UW/3940UW and Connecting SCSI Devices

- 3 Loosen the six large screws on the corners and sides of the computer's back panel. Do not completely remove the screws or the back panel.

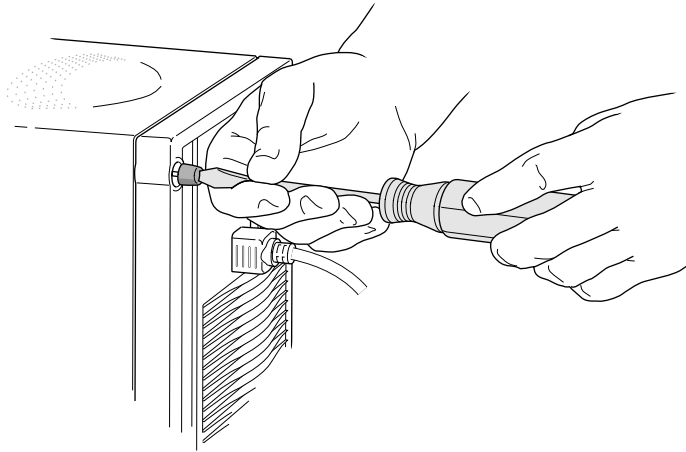

- 4 Remove the front cover.
 - a With the front of the computer facing you, place one hand on either side of the cover.
 - b Slide the cover toward you about 8 in.
 - c Lift the cover straight up and off the computer.

Refer to your computer user documentation if you need more information about removing the cover.

Slide cover toward you approximately 8 in.

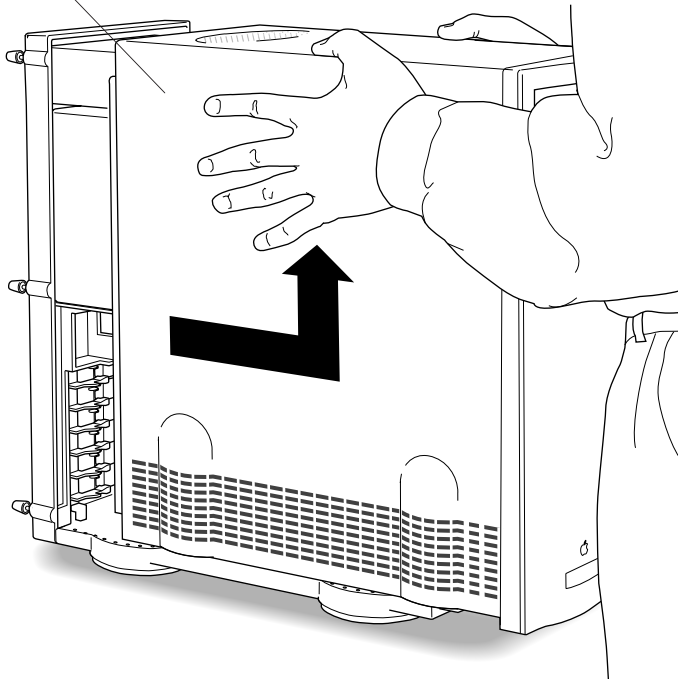

Installing the PowerDomain 2940UW/3940UW and Connecting SCSI Devices

- 5 Touch the metal part of the power supply to discharge any static electricity from your clothes and body. (Use a wrist grounding strap if you have one.)



Caution: Be sure to do this step before you touch any parts inside the computer, install the PowerDomain 2940UW/3940UW, or install any internal devices.

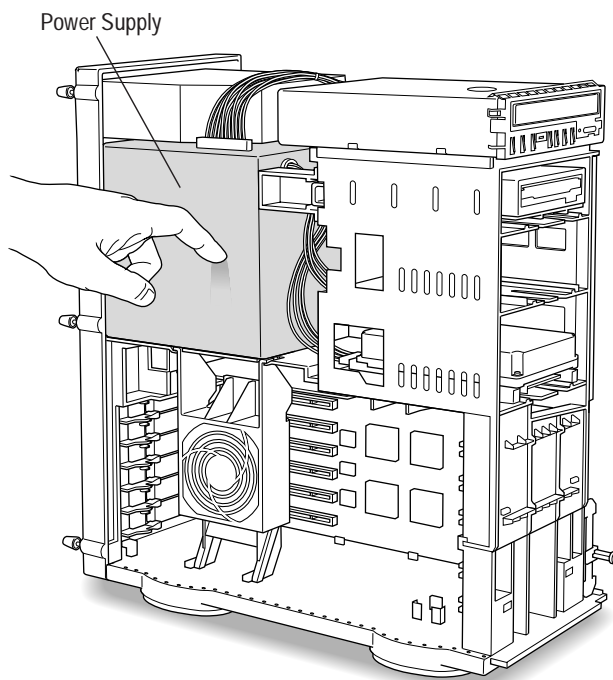

- 6 Lower the auxiliary fan.
 - a Release the auxiliary fan by squeezing the sides of the fan housing just below the power supply.
 - b Continue to squeeze while pulling down on the fan.

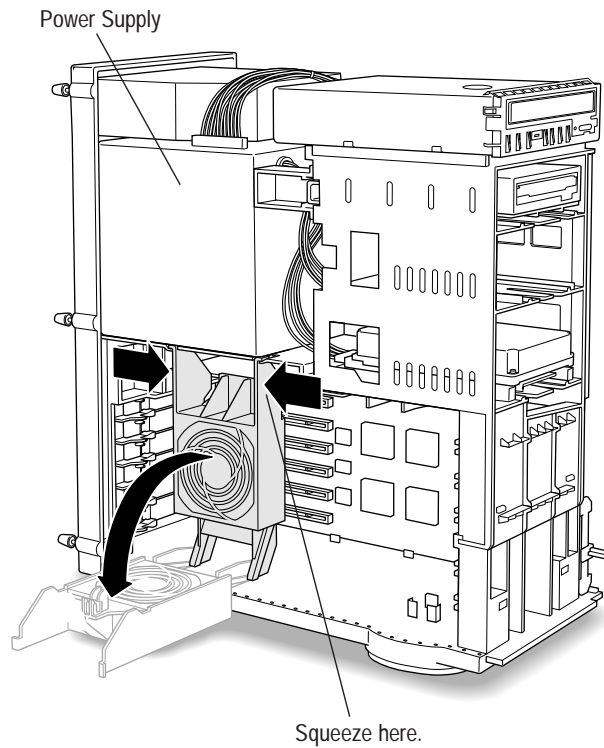

- 7 Choose an empty PCI expansion card slot, and remove its port access cover.
 - a To release the port access cover, spread the two tabs apart.



WARNING: Be careful not to touch the sharp edges of the port access cover.

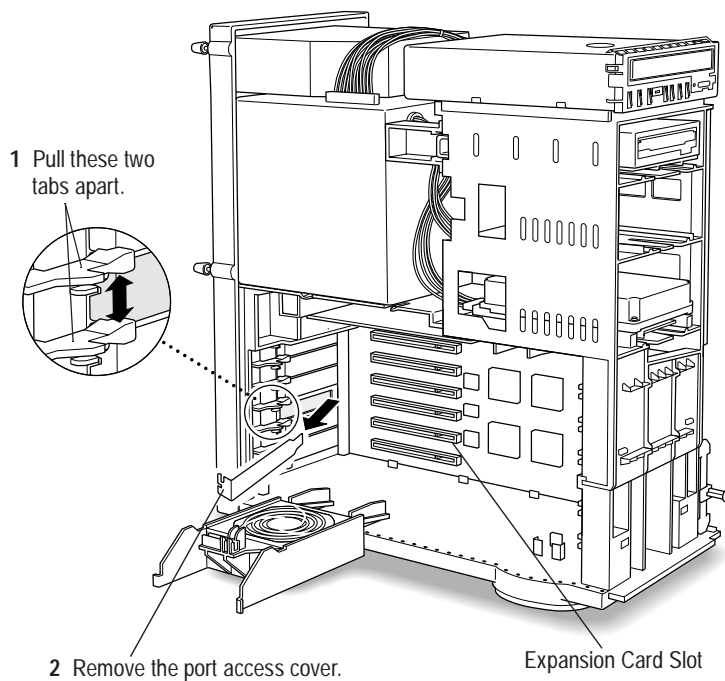

- b** Pull the front portion of the port access cover away from the computer case about 15 degrees.
 - c** Pull the port access cover toward you to remove it from the computer.
 - d** Store the port access cover in a safe place in case you need to use it again.
- 8** Remove the PowerDomain 2940UW/3940UW from its conductive tray. Hold the card by its edges to avoid touching the components.

Place the card on top of the tray if you need to put the card down.

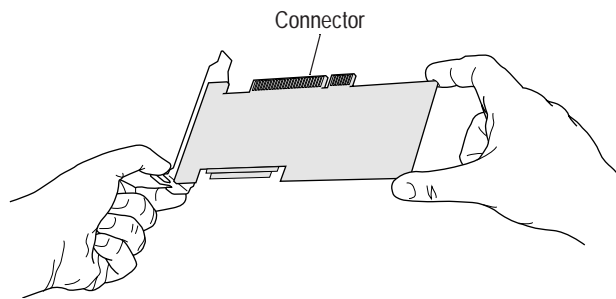

3940UW/3940UW Use Guide
Number: 510864-00, Rev. B
Print Spec Number: 493742-00
Current Date: 2/20/96 ECN Date: 2/20/96

P
ca
aga

...ables and Devices on

2790

Installing the PowerDomain 2940UW/ 3940UW—Desktop Models



Note: If your desktop model differs from the model illustrated in this manual, refer to your computer user documentation for instructions on installing an expansion card. (Instructions for tower models begin on page 2-2.)

To install the PowerDomain 2940UW/3940UW in your desktop-model computer

- 1 Turn OFF the power to the computer and any attached devices, and disconnect all power cords.



WARNING: To avoid possible exposure to electric shock, be sure all power to your system is turned OFF.

- 2 Press the computer's power button. This will dissipate the charge in the power supply capacitors.
- 3 Locate the two release buttons under the front panel ledge with your fingertips.

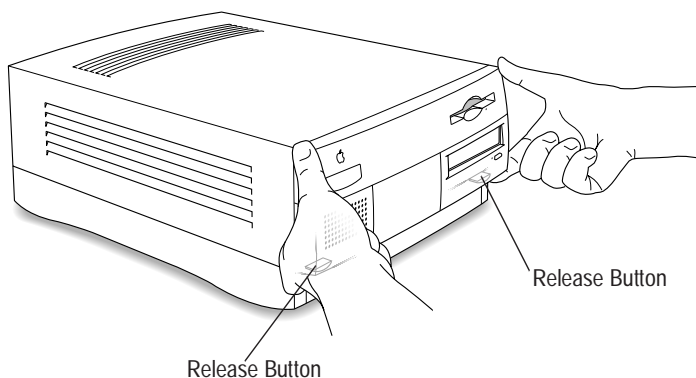

- 4** To release the cover from the computer chassis
 - a** Position the computer so its front is facing you.
 - b** Press and hold the release buttons.
 - c** Pull the cover toward you approximately 2 in.



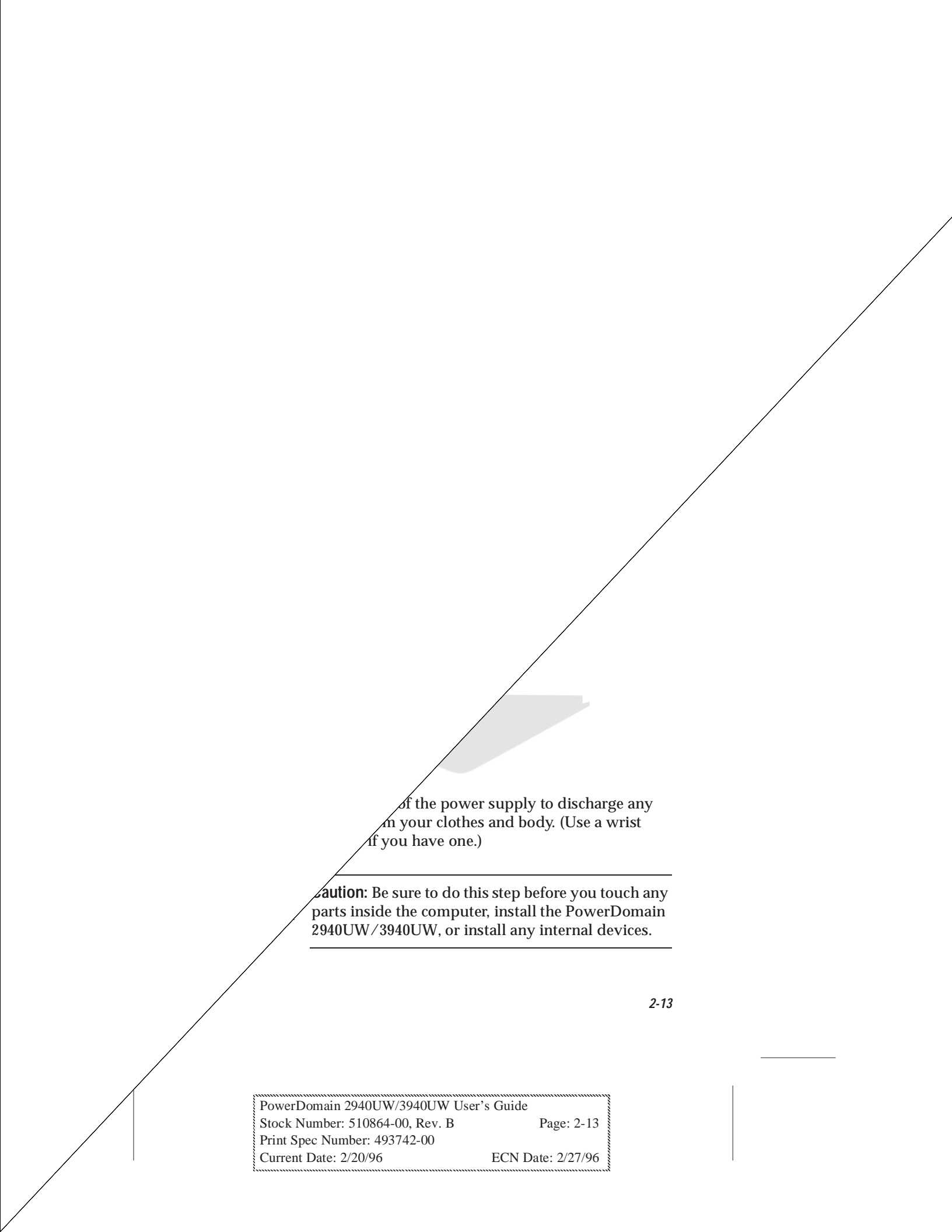

of the power supply to discharge any
in your clothes and body. (Use a wrist
if you have one.)

Caution: Be sure to do this step before you touch any
parts inside the computer, install the PowerDomain
2940UW/3940UW, or install any internal devices.

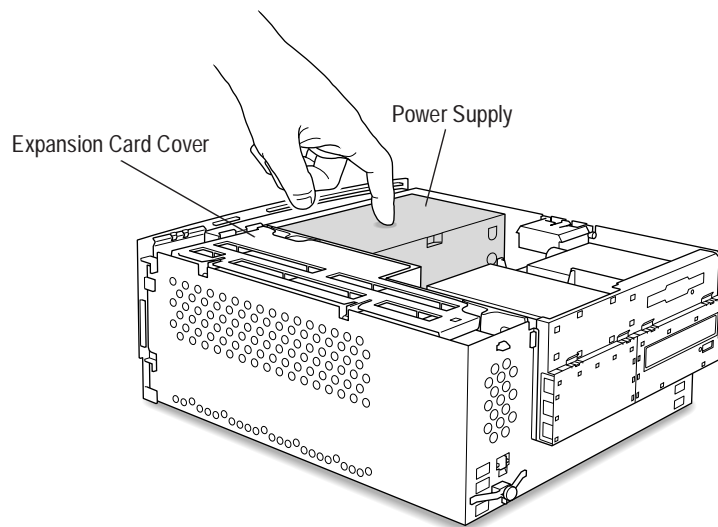

7 Open the expansion card cover.

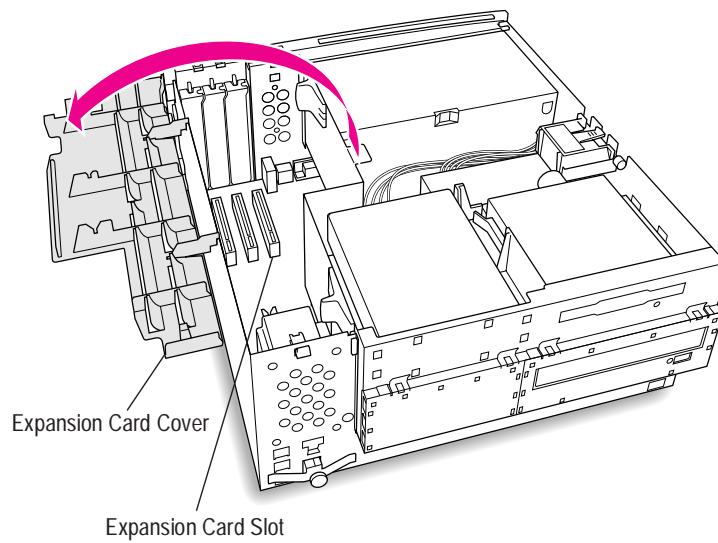

Installing the PowerDomain 2940UW/3940UW and Connecting SCSI Devices

- 8 Choose an empty PCI expansion card slot, and remove its port access cover. (The three port access covers are located at the back of the computer.)
 - a Grasp the port access cover with your right hand.



WARNING: Be careful not to touch the sharp edges of the port access cover.

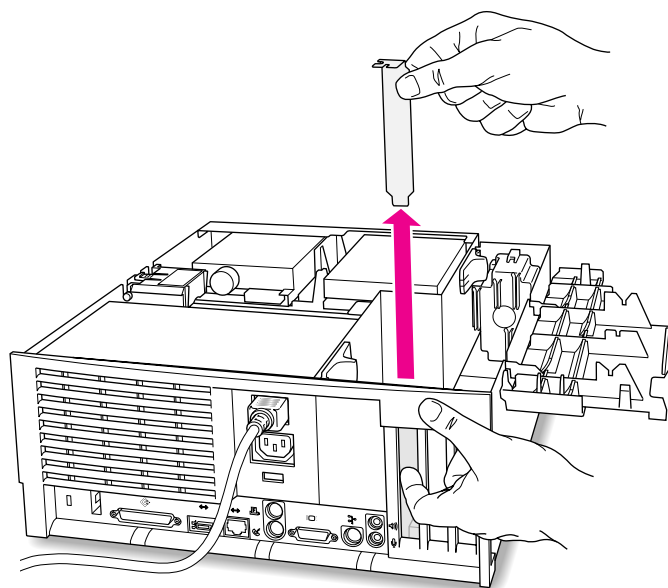

(Back of Computer)

Installing the PowerDomain 2940UW/3940UW and Connecting SCSI Devices

- 10 Position the PowerDomain 2940UW/3940UW accelerator card so its components face the expansion card cover. Align the left side of the card with the port access opening, and align the connector with the expansion card slot.

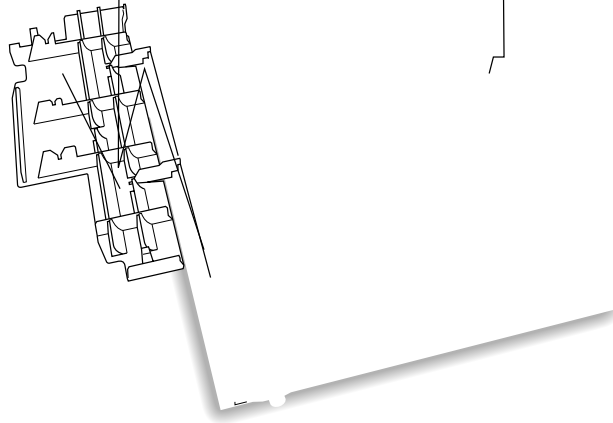

- 11 Insert the connector end of the PowerDomain 2940UW/3940UW firmly into the expansion card slot.
 - a Hold the PowerDomain 2940UW/3940UW at a 15-degree angle while you insert the right corner of the connector into the empty expansion card slot and the back left corner of the card into the access port opening.

- b** Push the PowerDomain 2940UW/3940UW into the expansion card slot as far as it will go.



Caution: *Do not* force the card. If you're having trouble installing it, carefully remove the card and try installing it again.

- c** Pull on the accelerator card slightly. If it stays in place, the card is securely seated. If it doesn't, try installing the card again.

PowerDomain 2940UW/3940UW

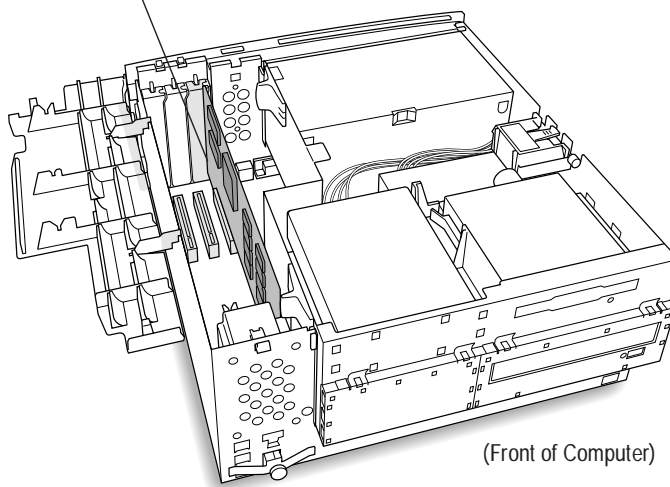

- 12** Continue with the next section, *Connecting SCSI Cables and Devices*.

Co

SCS
the
SCS
inclu

The P
16-bit
conne
can be
various

e and Devi

a s in one con
s of an accele
e o it. The SCS
a e devices.

o internal an
c one internal
1 SCSI device
n maximum of t

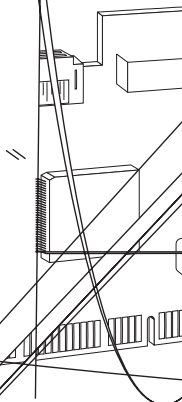

Caution: Do not
connectors of a

PowerDomain 2940UW/3940UW User's
Stock Number: 510864-00, Rev. B
Print Spec Number: 493742-00
Current Date: 2/20/96

ECN Date:

Choosing SCSI Cables

Always use high-quality SCSI cables to connect the PowerDomain 2940UW/3940UW to devices on the SCSI chain. Poor-quality cables can cause data corruption and other problems.

The round cables used for external SCSI devices vary widely in quality and electrical characteristics. Be sure external SCSI cables meet SCSI-2 standards. (Your cable reseller should be able to verify this.)

When purchasing external SCSI cables

- Choose external round-shielded cables with a single-ended impedance range of 80 to 110 ohms.
- Make sure all cables in the chain have the same wire gauge: at least #28 AWG for the PowerDomain 2940UW and at least #30 AWG for the PowerDomain 3940UW. (The gauge is usually printed on the cable.)



Note: Adaptec sells high-quality internal and external SCSI-2 cables, which you can purchase by calling Adaptec at the number listed on page iii.

To assure reliable operation, the total length of the SCSI chain, including both internal and external cabling, should not exceed 6 m (19.5 ft).

When calculating the total length of the SCSI chain, consider the following:

- The length of cables inside external cases. A drive might have up to 12 in. of cabling inside.
- The number of connections. One connection equals approximately 6 in.

- Any change in cable impedance, including the following
 - A change in wire gauge from one cable to the next
 - A change in the type of wire from one cable to the next
 - A change in the type of insulation from one cable to the next
 - A change from twisted-pair to ribbon cables, which often happens in drive cases

The effects of impedance changes will reduce the maximum reliable length of the SCSI chain.

- The maximum length of stub (drop) cables is 10 cm (4 in.), and the minimum spacing between stub cables is 30 cm (12 in.).
- Flat single-ended cables should be spaced at least 0.05 in. from the cable itself (when the cable is folded), from other cables, and from any metallic part of the system.

Connecting Internal SCSI Devices



Note: If you are not installing internal SCSI devices, turn to *Connecting External SCSI Devices—Tower Models* on page 2-34 or *Connecting External SCSI Devices—Desktop Models* on page 2-41.

Before installing an internal SCSI device, refer to the documentation included with the device for installation instructions. Sometimes a SCSI device must be installed before you can connect it to the accelerator card.

Installing the PowerDomain 2940UW/3940UW and Connecting SCSI Devices

To attach devices to the 50-pin internal connector of the PowerDomain 2940UW, use a 50-pin Narrow ribbon cable. To attach devices to the 68-pin internal connectors of the PowerDomain 2940UW/3940UW, use 68-pin Wide ribbon cables. Make sure your SCSI ribbon cable(s) have enough connectors to accommodate all your internal SCSI devices.

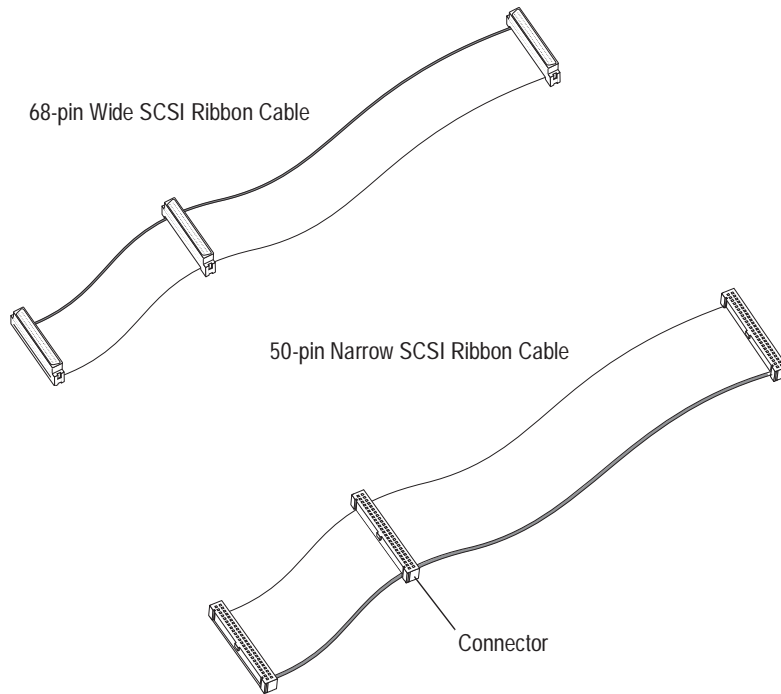



Caution: When arranging ribbon cables so they'll fit in the computer, be careful not to crease them.

