

Installation Guide

IDE-16052



An Adaptec Company

IDE-16052 Installation Guide
Part Number: 510999-00, Rev. B
Print Spec Number: 494453-00
Current Date: 4/29/96 ECN Date: 5/7/96

Description

The Future Domain[®] IDE-16052 is a low-cost, multi-function host adapter for ISA-bus computers. This dual-channel, double-word (32-bit), Enhanced IDE (EIDE) host adapter contains an onboard BIOS that enables you to boot from hard drives and identify all IDE peripheral devices without additional software. The IDE-16052 provides dual EIDE channels that support up to four IDE (ATA) devices and high-performance double-word (32-bit data transfers) plus:

- A floppy controller that supports two floppy disk drives, each with a capacity of up to 2.88MBytes
- A high-performance parallel port with standard parallel port (SPP), enhanced parallel port (EPP), and enhanced capabilities port (ECP) modes
- Two high-speed serial ports (16550-compatible UARTs)

The IDE-16052 host adapter is ideal for users who need affordable compatibility for their EIDE devices and high-performance connectivity to the outside world.

Configuration

The IDE-16052 host adapter shown in the following illustration occupies one 16-bit ISA-bus expansion slot.

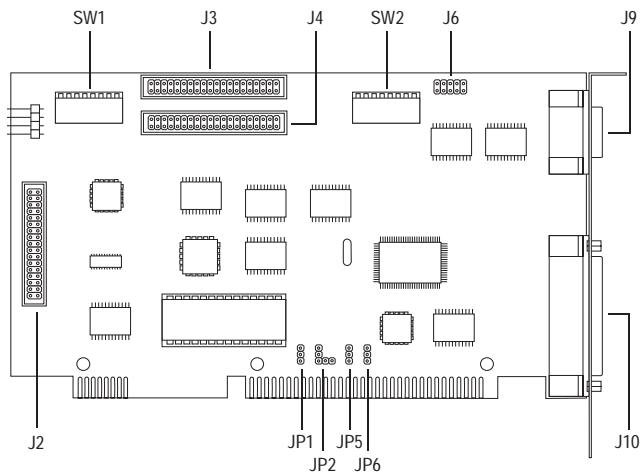

Location	Description
SW1	Switch block 1
J3	IDE-A (Primary IDE channel A)
J4	IDE-B (Secondary IDE channel B)
SW2	Switch block 2
J6	COM2/COM4 (Serial port)
J9	COM1/COM3 (Serial port)
J10	LPT 1/LPT 2 (Parallel port)
JP1, JP2, JP5, JP6	IRQ/DMA jumpers
J2	Floppy port

Attach IDE/ATA devices to host adapter connectors J3 and J4 via an HCA-302 data cable. (See the following illustration.) One data cable is required for each IDE channel. You may attach up to two IDE devices to each data cable. If you attach only one IDE/ATA device to a data cable, you must connect that device to the end of the cable.

Attach floppy drives to host adapter connector J2 via an HCA-105 floppy cable. (See the following illustration.) Install floppy device 0 (3.5- or 5.25-inch) at the end of the cable. Install floppy device 1 (3.5- or 5.25-inch) in the middle of the cable.

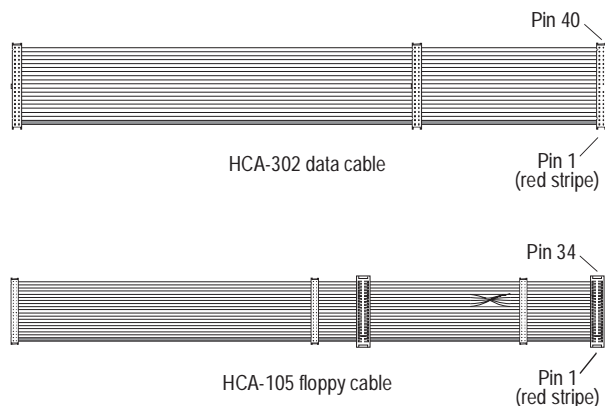

Attach the first serial device to external connector J9 on the host adapter. Attach the second serial device to external connector J7 on the HCA-138 serial bracket, which is supplied with the IDE-16052. (See the following illustration.) For instructions on installing the HCA-138 serial bracket, see step 6 on page 8.

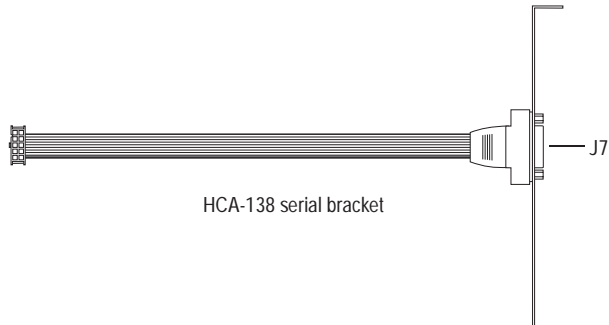

BIOS Memory Address

The IDE-16052 host adapter contains an advanced BIOS that supports hard drives larger than 528MBytes and bootability from either IDE channel. In order to enable the advanced BIOS, you must set SW1, switch 8 (BIOS) down. The following figure illustrates a switch block and its up (0) and down (1) settings.

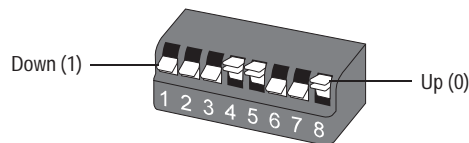

Use SW1, switches 4 (MEM-2), 5 (MEM-1), and 6 (MEM-0) to set the memory address for the *host adapter BIOS*. These switches allow you to avoid conflicts with either the *system BIOS* or with other add-in cards by changing the assigned BIOS address.

IDE Channels

The IDE-16052 has two IDE channels—primary IDE-A (J3) and secondary IDE-B (J4)—which support up to four IDE devices.

Use SW1, switches 1 (IOS-1) and 2 (IOS-0) to set the I/O ports. Set SW1, switch 7 down to enable the IDE-A channel. Set SW1, switch 3 down to enable the IDE-B channel.

Note: I/O ports and IRQs are grouped in pairs.

You can attach the boot drive to the primary or secondary IDE channel. The hard drive boot sequence is 1F0h, 170h, 168h, 1E8h.

Note: The *system BIOS* (CMOS defaults) is typically set to control the primary IDE channel. In order to use the IDE-16052 *host adapter BIOS*, you must set the Hard Drive Type in the system CMOS Setup to **Not Installed**

Floppy Port

Use SW2, switch 8 (FLOPPY) to enable or disable the floppy port. Set SW2, switch 8 up to disable the floppy port; set switch 8 down to enable the floppy port.

Floppy Port	FLOPPY
Disable	0
Enable*	1

* Default setting; 0 = up; 1 = down

Note: The primary floppy port address is 3F0h–3F7h. You cannot have two floppy controllers enabled at the same time. For example, you cannot enable both the floppy controller on the motherboard and the floppy controller on the IDE-16052.

Parallel Port

The IDE-16052 has one parallel port, which you can configure as LPT 1 or LPT 2. Use SW2, switches 1 (MODE-1), 2 (MODE-2), and 3 (LPT1/2) and jumpers JP1, JP2, JP5, and JP6 to configure the parallel port.

Parallel Port	LPT 1/2
LPT 1*	1
LPT 2	0

* Default setting; 0 = up; 1 = down

Parallel Port Transfer Mode

The IDE-16052 is capable of SPP, EPP, and ECP modes. Use SW2, switches 1 (MODE-1) and 2 (MODE-2) to set the parallel port transfer mode. [The ECP mode requires setting jumpers JP5 or JP6; refer to the next section, *DREQ and DACK Lines (ECP Mode Only)*, for these configurations.]







Parallel Port Transfer Mode	MODE-1	MODE-2
SPP (Default)	1*	1
ECP	0	1
EPP	1	0
Disable	0	0

* 0 = up; 1 = down

DREQ and DACK Lines (ECP Mode Only)

Use JP5 and JP6 to set the DMA request (DREQ) and DMA acknowledge (DACK) lines for DMA channels 1 or 3. Use the ECP/EPP setting if ECP is enabled, otherwise; use the SPP default setting.

Note: DREQ and DACK channel numbers (1/3) must be paired.



DREQ/DACK	JP5	JP6	Setting
SPP (Default)			Pins 1, 2, and 3 off
DREQ/DACK 1			
ECP/EPP with DMA 1			Pin 1 off; pins 2 and 3 on
DREQ/DACK 3			
ECP/EPP with DMA 3			Pins 1 and 2 on; pin 3 off

Enable/Disable Parallel Port

Set SW2, switch 3 (LPT1/2) down to enable LPT 1; set SW2, switch 3 up to enable LPT 2.

Parallel Port Interrupts

Use JP2 to set the interrupts for the parallel ports. Use the LPT 1/2 setting that matches the one you made in the previous section, *Enable/Disable Parallel Port*.

Parallel Port, IRQ	JP2	Setting
LPT 1, IRQ 7		Pin 1 off; pins 2 and 3 on
LPT 2, IRQ 5		Pins 1 and 2 on; pin 3 off

Serial Port

The IDE-16052 has two high-speed serial ports, which can be configured as COM 1/3 and/or COM 2/4.



Serial Port 1

Use SW2, switch 6 (COM1/3) to select COM 1 or COM 3. Use SW2, switch 7 (ENABLE) to enable or disable serial port 1.

COM 1 or COM 3	COM1/3	ENABLE
COM 1*	1	1
COM 3	0	1
Disable	x	0

* Default setting; 0 = up; 1 = down; x = up or down

Use JP1 to set the interrupts for serial port 1.

COM Port, IRQ	JP1	Setting
COM 1, IRQ 4		Pin 1 off; pins 2 and 3 on
COM 3, IRQ 9		Pins 1 and 2 on; pin 3 off
COM 3, IRQ 4*		Pin 1 off; pins 2 and 3 on

* These settings apply when SW2, switch 6 is set up and switch 7 is set down.



Serial Port 2

Use SW2, switch 4 (COM2/4) to select COM 2 or COM 4. Use SW2, switch 5 (ENABLE) to enable or disable serial port 2.

COM 2 or COM 4	COM2/4	ENABLE
COM 2*	1	1
COM 4	0	1
Disable	x	0

* Default setting; 0 = up; 1 = down; x = up or down

Use JP2 to set the interrupts for serial port 2.

COM Port, IRQ	JP2	Setting
COM 2, IRQ 3		Pin 1 off; pins 2 and 3 on
COM 4, IRQ 5		Pins 1 and 2 on; pin 3 off
COM 4, IRQ 3*		Pin 1 off; pins 2 and 3 on

* These settings apply when SW2, switch 4 is set up and switch 5 is set down.

Installation

- 1 Turn OFF the power to your computer and any attached devices, and disconnect the power cord.



WARNING: To avoid possible exposure to electric shock, be sure the power to your system is turned OFF.

- 2 Remove the cover from the computer case.
- 3 Touch an unpainted metal part of the computer to discharge any static electricity from your clothes and body. (Use a wrist grounding strap if you have one.)
- 4 Carefully remove the IDE-16052 from its antistatic packaging.
- 5 Configure the host adapter's jumpers and switches according to the settings in *Configuration*, which begins on page 1.
- 6 Replace the expansion slot cover of an empty slot with the HCA-138 serial bracket provided with the host adapter, and attach the serial bracket's cable to connector J6.

- 7 Attach internal cables and devices to the following connectors, as needed:

Connector	Device
J2	Floppy drives
J3, J4	IDE or EIDE devices

- 8 Choose an empty 16-bit ISA-bus expansion slot, and remove its slot cover. (Be sure to save the screw.)
- 9 Holding the IDE-16052 host adapter with both hands, align it with the slot and insert the host adapter firmly into the socket.
- 10 Attach the host adapter bracket to the computer chassis with the screw from the expansion slot cover you removed in step 8.
- 11 Attach external devices to the following connectors, as needed:

Connector	Device
J9	Serial device
J10	Parallel device
J7	Serial device

- 12 Replace the cover on the computer case.
- 13 Reconnect the power cords to all external devices and the computer.
- 14 Turn ON the power to the external devices, and then turn ON the power to the computer.
- 15 Make sure all hard disk drives connected to the IDE-16052 are set to **Not Installed** in system CMOS Setup. Refer to your computer documentation for more information.
- 16 Make sure all IDE devices are recognized by the IDE-16052 BIOS scan (SW1, switch 8 must be set down) and displayed on the monitor during bootup.

Specifications

Host bus	ISA; one 16-bit slot
Peripheral bus	IDE (ATA-2); dual channel
Command set	ATA-2, SFF-8020, ATAPI CD-ROM, QIC-157 tape standards
Transfer method	PIO mode 0, double-word (32-bit)
IDE interrupts	IRQ 14; IRQ 15; IRQ 10; IRQ 11
IDE I/O ports	1F0h; 170h; 160h/168h; 1E8h
Floppy	Up to two; 360KBytes, 720KBytes, 1.2MBytes, 1.44MBytes, 2.88MBytes capacity
Serial	<i>Transfer speed:</i> Up to 115.2Kbits/sec
	<i>Serial ports:</i> two; 03F8h (COM 1*); 02F8h (COM 2*); 03E8h (COM 3); 02E8h (COM 4)
	<i>Interrupts:</i> IRQ 3*; IRQ 4*; IRQ 5; IRQ 9
Parallel	<i>Mode support:</i> Standard parallel port (SPP)* Enhanced parallel port (EPP) Enhanced capabilities port (ECP)
	<i>Transfer speed:</i> Up to 2MBytes/sec (ECP)
	<i>Parallel ports:</i> one; 0378h (LPT 1*); 0278h (LPT 2)
	<i>Interrupts:</i> IRQ 5; IRQ 7*

* Default settings

Troubleshooting

The IDE-16052 has been configured to work with either single or dual IDE channel motherboards. The host adapter will display the following BIOS messages during the power-on self-test (POST):

```
Scanning for IDE controllers and devices...
Controller 0 at IO port XXXh, IRQ YY...
    Device 0 - ZZZ                F/W Rev.
    Device 1 - ZZZ                F/W Rev.
Controller 1 at IO port XXXh, IRQ YY...
    Device 0 - ZZZ                F/W Rev.
    Device 1 - ZZZ                F/W Rev.
```

Where:

XXX = the I/O port location of the IDE channels
YY = the IRQ selection of the IDE channels
ZZZ = the name of the IDE or EIDE devices

If you do not see the BIOS message or if you are having problems installing your EIDE host adapter, try the following:

- 1 Make sure the IDE-16052 BIOS is enabled, i.e., SW1, switch 8 is set down.
- 2 Change the memory address of the BIOS (refer to *BIOS Memory Address* on page 3). It might be conflicting with a video controller or other controller using a ROM BIOS.

Note: Make sure the EIDE adapter is not conflicting with another add-in host adapter or IDE channel on the motherboard.

If there is another EIDE host adapter or IDE connector on the motherboard, check the number of IDE connectors. If there is only one connector, then the primary IDE channel (I/O port 1F0h, IRQ 14) is in use. If there are two connectors, the primary and secondary IDE channels (I/O port 170h, IRQ 15) are in use.

To avoid conflicts, use an alternate IDE channel. Refer to *IDE Channels* on page 4 for instructions.

- 3 Make sure the EIDE device is correctly configured either as device 0 (master) or device 1 (slave). Refer to the device documentation for more information.

- 4 The IDE channel (1E8h/IRQ 11) might conflict with the COM 3 alternate status register (3EEh) when using certain types of communication software. Attach your serial device to a different COM port, or use a different I/O port for the IDE device.
- 5 Certain PCI video controllers use I/O ports 2ECh–2EEh. These ports conflict with the COM 4 I/O port range of 2E8h–2EEh. Change the COM port setting, or try a different video card.

Adaptec Technical Support and Services

If you have questions about installing or using the host adapter, check this installation guide first—you will find answers to most of your questions here. If you need further assistance, please contact us. We offer the following support and information services:

Electronic Support

Technical information, including product literature, answers to commonly asked questions, information on software upgrades and other topics, is available electronically through the following:

- Adaptec World Wide Web (WWW) site at <http://www.adaptec.com>.
- File Transfer Protocol (FTP) server at <ftp.adaptec.com>.
- CompuServe Adaptec Forum at GO ADAPTEC.
- Adaptec USA Bulletin Board Service (BBS) at 408-945-7727; supports up to 28,800 bps (bits per second), 8 data bits, 1 stop bit, no parity. No product literature is available on the Adaptec BBS.
- Interactive Fax System at 408-957-7150; available 23 hours a day, 7 days a week. The fax system is out of service 1 hour each day.

Technical and Product Support

- For technical support and information about Adaptec's electronic support services, call 800-959-SCSI (7274) or 408-945-2550, 24 hours a day, 7 days a week.
- To use the Adaptec Interactive Support System, call 800-959 SCSI (7274) or 408-945-2550, 24 hours a day, 7 days a week. The system prompts you with questions regarding your problem and then provides step-by-step troubleshooting instructions.
- To speak with a product support representative, call 408-934-SCSI (7274), M–F, 6:00 A.M. to 5:00 P.M., Pacific Time. After hours, on weekends, and on holidays, product support is also available for a fee at 800-416-8066.

Sales and Ordering Information

- For sales information, call 800-959-SCSI (7274) or 408-945-2550, M–F, 6:00 A.M. to 5:00 P.M., Pacific Time.
- To order Adaptec software and SCSI cables, call 800-442-SCSI (7274) or 408-957-SCSI (7274), M–F, 6:00 A.M. to 5:00 P.M., Pacific Time.
- To request additional documentation for Adaptec products, call 800-934-2766 or 510-732-3829, M–F, 6:00 A.M. to 5:00 P.M., Pacific Time.

FCC Compliance Statement

This equipment has been tested and found to comply with the limits for a Class B digital device, pursuant to Part 15 of the FCC rules. These limits are designed to provide reasonable protection against harmful interference in residential installations. This equipment generates, uses, and can radiate radio frequency energy, and if not installed and used in accordance with the instructions, may cause harmful interference to radio communications. However, there is no guarantee that interference will not occur in a particular installation.

If this equipment does cause interference to radio or television equipment reception, which can be determined by turning the equipment off and on, the user is encouraged to try to correct the interference by one or more of the following measures:

- Reorient or relocate the receiving antenna
- Move the equipment away from the receiver
- Plug the equipment into an outlet on a circuit different from that to which the receiver is powered
- If necessary, the user should consult the dealer or an experienced radio/television technician for additional suggestions

CAUTION: Only equipment certified to comply with Class B (computer input/output devices, terminals, printers, etc.) should be attached to this equipment, and must have shielded interface cables.

Finally, any changes or modifications to the equipment by the user not expressly approved by the grantee or manufacturer could void the user's authority to operate such equipment.

Each host adapter is equipped with an FCC compliance label that shows only the FCC identification number. The full text of the associated label follows:

This device complies with part 15 of the FCC rules. Operation is subject to the following two conditions: (1) this device may not cause harmful interference and (2) this device must accept any interference received, including interference that may cause undesired operation.

Canadian Compliance Statement

This Class B digital apparatus meets all requirements of the Canadian Interference-Causing Equipment Regulations.

Cet appareil numérique de la classe B respecte toutes les exigences du Règlement sur le matériel brouilleur du Canada.



Adaptec, Inc.
691 South Milpitas Blvd.
Milpitas, CA 95035

Copyright © 1996, Adaptec, Inc. All rights reserved. Adaptec and the Adaptec logo are trademarks of Adaptec, Inc., which may be registered in some jurisdictions. Future Domain and the Future Domain logo are trademarks of Future Domain Corporation, which may be registered in some jurisdictions. All other trademarks are owned by their respective owners.

Printed in Singapore
Stock No.: 510999-00, Rev. B CW 4/96
Information subject to change without notice.