

# **BA430/BA440 Enclosure Maintenance**

Order Number EK-348AD-MG-004

**Digital Equipment Corporation  
Maynard, Massachusetts**

---

**First Printing, September 1990**

**Second Printing, July 1991**

**Third Printing, May 1992**

**Fourth Printing, October 1992**

The information in this document is subject to change without notice and should not be construed as a commitment by Digital Equipment Corporation.

Digital Equipment Corporation assumes no responsibility for any errors that may appear in this document.

The software, if any, described, in this document is furnished under a license and may be used or copied only in accordance with the terms of such license. No responsibility is assumed for the use or reliability of software or equipment that is not supplied by Digital Equipment Corporation or its affiliated companies.

**Restricted Rights:** Use, duplication or disclosure by the U.S. Government is subject to restrictions as set forth in subparagraph (c)(1)(ii) of the Rights in Technical Data and Computer Software clause at DFARS 252.227-7013.

©Digital Equipment Corporation 1990, 1991, 1992.

All Rights Reserved.

The Reader's Comments form at the end of this document requests your critical evaluation to assist in preparing future documentation.

The following are trademarks of Digital Equipment Corporation: CompacTape, CX, DDCMP, DEC, DECconnect, DECdirect, DECnet, DECscan, DECserver, DECUS, DECwindows, DELNI, DEMPR, DESQA, DESTA, DSRVB, DSSI, IVAX, KDA, KLESI, KRQ50, MicroVAX, MSCP, Q-bus, Q22-bus, RA, RQDX, RV20, RRD40, SA, SDI, ThinWire, TK, TMSCP, TQK, TSO5, TU, VAX, VAX 4000, VAXcluster, VAX DOCUMENT, VAXELN, VAXlab, VAXserver, VMS, VT, and the DIGITAL logo.

Velcro is a registered trademark of Velcro USA, Inc.

**FCC NOTICE:** The equipment described in this manual generates, uses, and may emit radio frequency energy. The equipment has been type tested and found to comply with the limits for a Class A computing device pursuant to Subpart J of Part 15 of FCC Rules, which are designed to provide reasonable protection against such radio frequency interference when operated in a commercial environment. Operation of this equipment in a residential area may cause interference, in which case the user at his own expense may be required to take measures to correct the interference.

S2043

This document was prepared using VAX DOCUMENT, Version 2.1.

# Contents

---

## Preface

xi

## Chapter 1 BA430/BA440 Enclosure Description

---

|         |   |      |
|---------|---|------|
| 1.1     | Overview  | 1-1  |
| 1.2     | Enclosure Keylock Access  | 1-3  |
| 1.3     | Module Handles and Covers   | 1-5  |
| 1.3.1   | Filler Panel Between Flush and Recessed Handles   | 1-8  |
| 1.4     | Mass Storage Shelf  | 1-9  |
| 1.5     | EF-Series, RF-Series and RZ-Series ISEs   | 1-11 |
| 1.6     | Tape Drives   | 1-15 |
| 1.7     | System Control Panel (SCP)  | 1-17 |
| 1.7.1   | Enclosure Modification  | 1-19 |
| 1.7.2   | Halt and Restart Switch Disable   | 1-19 |
| 1.8     | Enclosure Card Cage   | 1-20 |
| 1.8.1   | Components Specific to the DECsystem 5500 in a BA430 Enclosure                          | 1-21 |
| 1.8.1.1 | H3602-AC CPU Cover Panel Used in the DECsystem 5500                                     | 1-22 |
| 1.8.1.2 | H3605 I/O Panel Used in the DECsystem 5500  | 1-22 |
| 1.8.1.3 | M9715 Backplane Interface Module  | 1-24 |
| 1.8.2   | Components Specific to VAX 4000 Model 200 System in a BA430 Enclosure                   | 1-24 |
| 1.8.2.1 | H3602-AA CPU Cover Panel Used in VAX 4000 Model 200 (BA430 Only)                        | 1-25 |
| 1.8.2.2 | M9715 Backplane Interface Module  | 1-25 |
| 1.8.3   | Components Specific to VAX/VAXserver 4000 Models 300, 500, and 600 in a BA440 Enclosure | 1-26 |
| 1.8.3.1 | H3604 Console Module (Used in BA440 Enclosure)  | 1-27 |
| 1.9     | Power Supply (H7874)  | 1-32 |
| 1.9.1   | H7874 Power Supply Switches and Controls  | 1-33 |

|        |                                      |      |
|--------|--------------------------------------|------|
| 1.9.2  | H7874 Shutdown Mode .....            | 1-35 |
| 1.10   | Fan Tray .....                       | 1-36 |
| 1.10.1 | Fan Speed Control Disable .....      | 1-37 |
| 1.11   | Backplanes .....                     | 1-37 |
| 1.11.1 | BA430 Backplane .....                | 1-39 |
| 1.11.2 | BA440 Backplane .....                | 1-40 |
| 1.12   | Configuration Guidelines .....       | 1-41 |
| 1.12.1 | Module Order and Configuration ..... | 1-42 |
| 1.12.2 | Configuration Worksheets .....       | 1-42 |
| 1.13   | Power Requirements .....             | 1-46 |

## Chapter 2 Installation

---

|       |                                       |      |
|-------|---------------------------------------|------|
| 2.1   | Site Preparation .....                | 2-1  |
| 2.1.1 | BA430/BA440 Physical Dimensions ..... | 2-1  |
| 2.1.2 | Additional Equipment .....            | 2-2  |
| 2.1.3 | Static Electricity .....              | 2-2  |
| 2.1.4 | Acoustics .....                       | 2-3  |
| 2.1.5 | Heat Dissipation .....                | 2-3  |
| 2.1.6 | Temperature and Humidity Values ..... | 2-3  |
| 2.1.7 | Electrical Requirements .....         | 2-4  |
| 2.2   | Unpacking the Shipment .....          | 2-5  |
| 2.3   | Connecting the Console Terminal ..... | 2-7  |
| 2.4   | Completing the Installation .....     | 2-10 |
| 2.4.1 | Setting Controls on the System .....  | 2-12 |
| 2.4.2 | Connecting the Power Cable .....      | 2-13 |

## Chapter 3 BA430/BA440 FRU Removal and Replacement

---

|         |   |      |
|---------|---|------|
| 3.1     | Field Replaceable Units (FRUs) .....                | 3-2  |
| 3.2     | Removing Modules .....                              | 3-5  |
| 3.2.1   | Removing Modules with Ratchet Ejector Handles ..... | 3-6  |
| 3.2.2   | Removing Modules with Attached Handles .....        | 3-7  |
| 3.2.3   | Removing Modules with Covers .....                  | 3-9  |
| 3.2.4   | Special Modules .....                               | 3-10 |
| 3.2.4.1 | M9715-AA Interface Module (BA430 Enclosure Only) .. | 3-10 |

|           |  |      |
|-----------|--|------|
| 3.2.4.2   | M7638-AA I/O Module (BA430/DECsystem500) . . . . .                                     | 3-10 |
| 3.2.4.3   | Vterm Board Removal (BA440 Enclosure Only) . . . . .                                   | 3-10 |
| 3.3       | Replacing EF-, RF-, and RZ-Series ISEs . . . . .                                       | 3-11 |
| 3.3.1     | Removing an ISE from the Mass Storage Cavity . . . . .                                 | 3-11 |
| 3.3.2     | Replacing the Remote Front Panel Cable on a 3.5-inch<br>RF-series ISE . . . . .        | 3-15 |
| 3.3.3     | Replacing the ISE Front Panel Module . . . . .   | 3-15 |
| 3.3.4     | Replacing the Interface Card . . . . .   | 3-16 |
| 3.3.4.1   | Replacing the Interface Card on the 5.25-inch EF-, RF-<br>and RZ-Series ISEs . . . . . | 3-16 |
| 3.3.4.1.1 | Remove the Top Bracket . . . . .   | 3-17 |
| 3.3.4.1.2 | Install the New the Interface Card . . . . .   | 3-18 |
| 3.3.4.2   | Replace the Interface Card on 3.5-inch RF-Series ISEs . . . . .                        | 3-20 |
| 3.3.4.2.1 | Remove the Top Outside Bracket . . . . .   | 3-20 |
| 3.3.4.2.2 | Remove the Old Interface Card and Install the New<br>Interface Card . . . . .          | 3-21 |
| 3.3.5     | Replacing the Remote Front Panel Cable on 5.25-inch ISEs . . . . .                     | 3-23 |
| 3.3.6     | Replacing a Storage Device on a 5.25-inch RF- or RZ-Series<br>ISE . . . . .            | 3-25 |
| 3.3.7     | Replacing a Storage Device on a 3.5-inch RF-Series ISE . . . . .                       | 3-27 |
| 3.3.7.1   | Installing the New Storage Device . . . . .  | 3-30 |
| 3.3.8     | Replacing the Battery Pack on an EF-Series ISE . . . . .                               | 3-30 |
| 3.3.8.1   | Removing the Mounting Hardware from an EF-Series<br>ISE . . . . .                      | 3-30 |
| 3.3.8.2   | Replacing the Battery Pack in the Chassis . . . . .                                    | 3-33 |
| 3.4       | Replacing the TLZ04 Tape Drive . . . . .   | 3-35 |
| 3.4.1     | Remove the TLZ04 Tape Drive . . . . .  | 3-36 |
| 3.4.2     | Replacing the ID Cable . . . . .   | 3-38 |
| 3.4.3     | Replacing the TLZ04 Front Panel Module . . . . .                                       | 3-39 |
| 3.4.4     | Replacing the Interface Card Assembly . . . . .  | 3-40 |
| 3.4.4.1   | Removing the Top Mounting Bracket . . . . .  | 3-40 |
| 3.4.4.2   | Removing the Interface Card Assembly . . . . .   | 3-42 |
| 3.4.5     | Replacing the Tape Drive . . . . .   | 3-44 |
| 3.5       | Replacing a TK-Series Tape Drive . . . . .   | 3-46 |
| 3.5.1     | Replace the Interface Card . . . . .   | 3-47 |
| 3.5.2     | Replace the TK-Series Tape Drive . . . . .   | 3-49 |
| 3.6       | Replacing a TF-Series Tape Drive . . . . .   | 3-52 |

|        |  |      |
|--------|--|------|
| 3.6.1  | Replacing the TF-Series Front Panel Module . . . . . | 3-55 |
| 3.6.2  | Replacing the Interface Card Assembly . . . . .      | 3-56 |
| 3.6.3  | Replacing the Tape Drive . . . . .                   | 3-58 |
| 3.7    | Removing the System Control Panel (SCP) . . . . .    | 3-60 |
| 3.8    | Removing the Power Supply . . . . .                  | 3-61 |
| 3.9    | Removing Fans . . . . .                              | 3-64 |
| 3.10   | Removing a BA430/BA440 Backplane . . . . .           | 3-66 |
| 3.10.1 | Installing a BA430/BA440 Backplane . . . . .         | 3-72 |
| 3.10.2 | Reinstalling the Outer Shell . . . . .               | 3-73 |

## Appendix A Related Documentation

---

### Index

---

### Figures

---

|      |   |      |
|------|---|------|
| 1-1  | BA430/BA440 Pedestal Enclosures . . . . .                                   | 1-2  |
| 1-2  | Keylock Positions . . . . .   | 1-4  |
| 1-3  | BA400-Series Module Handles and Covers . . . . .                            | 1-8  |
| 1-4  | BA400-Series Chassis and Mass Storage Shelf . . . . .                       | 1-9  |
| 1-5  | EF-Series 5.25-inch ISE (Front and Rear View) . . . . .                     | 1-11 |
| 1-6  | RF- and RZ-Series full height 5.25-inch ISE (Front and Rear View) . . . . . | 1-12 |
| 1-7  | RF-Series 3.5-inch ISE Single Drive (Front and Rear View) . . . . .         | 1-13 |
| 1-8  | Front Panel Assemblies . . . . .  | 1-14 |
| 1-9  | TF-Series Tape Drive . . . . .  | 1-15 |
| 1-10 | TK70 Tape Drive . . . . .   | 1-16 |
| 1-11 | TLZ-Series Tape Drive . . . . .   | 1-17 |
| 1-12 | SCP Indicators . . . . .  | 1-18 |
| 1-13 | SCP Enable/Disable Switch Location . . . . .                                | 1-20 |
| 1-14 | BA430 Enclosure Backplane (DECsystem 5500) . . . . .                        | 1-22 |
| 1-15 | H3602-AC CPU Cover and H3605 I/O Panel, Used in DECsystem 5500 . . . . .    | 1-23 |
| 1-16 | BA430 Enclosure Backplane (VAX 4000 Model 200 System) . . . . .             | 1-25 |
| 1-17 | BA440 Enclosure Backplane . . . . .   | 1-27 |

|      |   |      |
|------|---|------|
| 1-18 | H3604 Console Module (Front) . . . . .  | 1-28 |
| 1-19 | H3604 Console Module (Rear) . . . . .   | 1-29 |
| 1-20 | Power Supply Indicators . . . . .   | 1-32 |
| 1-21 | Sample Power Bus Configuration . . . . .  | 1-35 |
| 1-22 | BA430/BA440 Fan Tray Location . . . . .   | 1-36 |
| 1-23 | Fan Tray Extended . . . . .   | 1-37 |
| 1-24 | FSC Jumper Location . . . . .   | 1-38 |
| 1-25 | BA430 Backplane . . . . .   | 1-40 |
| 1-26 | BA440 Backplane . . . . .   | 1-41 |
| 1-27 | BA430 Configuration Worksheet . . . . .   | 1-44 |
| 1-28 | BA440 Configuration Worksheet . . . . .   | 1-45 |
| 2-1  | BA430/BA440 Enclosure Dimensions . . . . .  | 2-2  |
| 2-2  | Sliding the System into Place . . . . .   | 2-6  |
| 2-3  | Connecting the Console Terminal to the BA430 . . . . .  | 2-8  |
| 2-4  | Connecting the Console Terminal to the BA440 . . . . .  | 2-9  |
| 2-5  | Connecting the Power Cable . . . . .  | 2-13 |
| 3-1  | Ratchet Ejector Handles . . . . .   | 3-7  |
| 3-2  | Releasing Quarter-Turn Captive Screws . . . . .   | 3-8  |
| 3-3  | Removing a Module . . . . .   | 3-9  |
| 3-4  | Remove the ISE . . . . .  | 3-13 |
| 3-5  | Removing an ISE Front Panel Module . . . . .  | 3-16 |
| 3-6  | Removing Bracket Screws . . . . .   | 3-17 |
| 3-7  | Removing the ISE Top Bracket . . . . .  | 3-18 |
| 3-8  | Replacing the Interface Card Assembly . . . . .   | 3-19 |
| 3-9  | Remove the Top Outside Bracket From the ISE . . . . .   | 3-21 |
| 3-10 | Replace the Interface Card . . . . .  | 3-22 |
| 3-11 | Removing the Remote Front Panel Cable . . . . .   | 3-24 |
| 3-12 | Removing the ISE Top Bracket . . . . .  | 3-26 |
| 3-13 | Remove the Top Outside Bracket From the ISE . . . . .   | 3-28 |
| 3-14 | Removing the Phillips Screws that Secure the Storage Device<br>to the Bottom Inside Bracket . . . . . | 3-29 |
| 3-15 | Removing the Top and Bottom Brackets of a 5.25-inch<br>EF-Series ISE . . . . .                        | 3-32 |
| 3-16 | Removing the Top of the Chassis on a 5.25-inch EF-Series<br>ISE . . . . .                             | 3-33 |
| 3-17 | Removing the Battery of a 5.25-inch EF-Series ISE . . . . .   | 3-34 |
| 3-18 | Removing the TLZ04 Tape Drive . . . . .   | 3-37 |

|      |   |      |
|------|---|------|
| 3-19 | Removing the ID Cable . . . . .                     | 3-39 |
| 3-20 | Removing the TLZ04 Front Panel Module . . . . .     | 3-40 |
| 3-21 | Removing Bracket Screws . . . . .                   | 3-41 |
| 3-22 | Removing the Top Mounting Bracket . . . . .         | 3-42 |
| 3-23 | Removing the Interface Card Assembly . . . . .      | 3-43 |
| 3-24 | Removing the Tape Drive . . . . .                   | 3-45 |
| 3-25 | Releasing TK-Series Captive Screws . . . . .        | 3-46 |
| 3-26 | Removing a TK-Series Drive Unit . . . . .           | 3-47 |
| 3-27 | Removing the Top Mounting Bracket . . . . .         | 3-48 |
| 3-28 | Removing Bracket Screws . . . . .                   | 3-49 |
| 3-29 | Removing the Top Mounting Bracket . . . . .         | 3-50 |
| 3-30 | Removing a TK-Series Cable . . . . .                | 3-52 |
| 3-31 | Removing a TF-Series Drive Unit . . . . .           | 3-54 |
| 3-32 | Removing the TF-Series Front Panel Module . . . . . | 3-55 |
| 3-33 | Removing Bracket Screws . . . . .                   | 3-56 |
| 3-34 | Removing the Top Mounting Bracket . . . . .         | 3-57 |
| 3-35 | Removing the Interface Card Assembly . . . . .      | 3-58 |
| 3-36 | Removing the Top Mounting Bracket . . . . .         | 3-59 |
| 3-37 | Removing the System Control Panel (SCP) . . . . .   | 3-61 |
| 3-38 | Removing the Power Supply Cable . . . . .           | 3-62 |
| 3-39 | Discharging the Power Supply . . . . .              | 3-63 |
| 3-40 | Removing the Power Supply . . . . .                 | 3-64 |
| 3-41 | Removing the Fan Tray . . . . .                     | 3-65 |
| 3-42 | Removing the Fan Assembly . . . . .                 | 3-66 |
| 3-43 | Outer Shell Removal . . . . .                       | 3-68 |
| 3-44 | Bus Cable Locations (BA440) . . . . .               | 3-69 |
| 3-45 | Rear Panel Removal (BA430/BA440) . . . . .          | 3-71 |
| 3-46 | Removing a Backplane . . . . .                      | 3-72 |
| 3-47 | Door Installation . . . . .                         | 3-75 |

## Tables

---

|     |   |      |
|-----|---|------|
| 1-1 | BA400-Series Module Handle and Cover Types . . . . .  | 1-6  |
| 1-2 | SCP Switches and Functions . . . . .  | 1-20 |
| 1-3 | DECsystem 5500 Module Order . . . . .   | 1-21 |
| 1-4 | VAX 4000 Model 200 (BA430) Module Order . . . . .   | 1-24 |
| 1-5 | BA440 Module Order . . . . .  | 1-26 |
| 1-6 | H3604 Console Module Fuses . . . . .  | 1-30 |
| 1-7 | Controls, Ports, and Indicators Available on the H3604 and<br>H3602 Console Modules . . . . . | 1-31 |
| 1-8 | H7874 Power Supply Switches, Controls,<br>and Indicators . . . . .                            | 1-33 |
| 1-9 | Power Requirements . . . . .  | 1-46 |
| 2-1 | Temperature and Relative Humidity Values . . . . .  | 2-3  |
| 2-2 | BA430/BA440 Enclosure Electrical Requirements . . . . .                                       | 2-4  |
| 2-3 | Power Cables . . . . .  | 2-4  |
| 2-4 | Module Identification Labels . . . . .  | 2-10 |
| 2-5 | Option Cables . . . . .   | 2-12 |
| 3-1 | BA430/BA440 FRUs . . . . .  | 3-2  |

# Preface

---

This manual provides reference, installation, and maintenance information for the BA430 and BA440 enclosures.

## Intended Audience

This document is intended only for Digital service personnel and qualified self-maintenance customers.

## Organization

This manual has three chapters and one appendix.

Chapter 1 provides an overview of the system enclosures, describing controls, mass storage area and capacity, backplane, signal distribution, power distribution, I/O connections, and configuration guidelines.

Chapter 2 lists site preparation considerations and procedures for installing the BA430/BA440 office pedestal configuration.

Chapter 3 describes removal and replacement procedures for field-replaceable units (FRUs). This chapter contains a list of the BA430/BA440 FRUs.

Appendix A contains a list of related documentation.

## Notes, Cautions, and Warnings

Notes, cautions, and warnings appear throughout this manual. They have the following meanings:

**NOTE** Provides general information about the current topic.

**CAUTION** Provides information to prevent damage to equipment or software.

**WARNING** Provides information to prevent personal injury.

The following symbols appear on the system power supply. Please review their definitions below:



This warning symbol indicates risk of electric shock.

Warning. To reduce the risk of injury, do not remove modules, Integrated Storage Elements (ISEs), or the power supply. No user-serviceable parts are inside.

This equipment has not been designed for connection to an IT power system. (a power system without a directly grounded neutral conductor).

This equipment should be plugged into a properly grounded receptacle only.

This system contains an automatic voltage select power supply. Voltage selection is not required prior to installation.

# BA430/BA440 Enclosure Description

---

## 1.1 Overview

The BA430/BA440 enclosure shown in Figure 1-1 was designed to be used as a freestanding pedestal in an office environment. The BA430/BA440 consists of the following components:

- Dual front door
- Mass storage shelf for tape and disk ISEs
- System control panel (SCP)
- Enclosure card cage
- Power supply
- Fan tray
- Backplane

**Figure 1-1: BA430/BA440 Pedestal Enclosures**

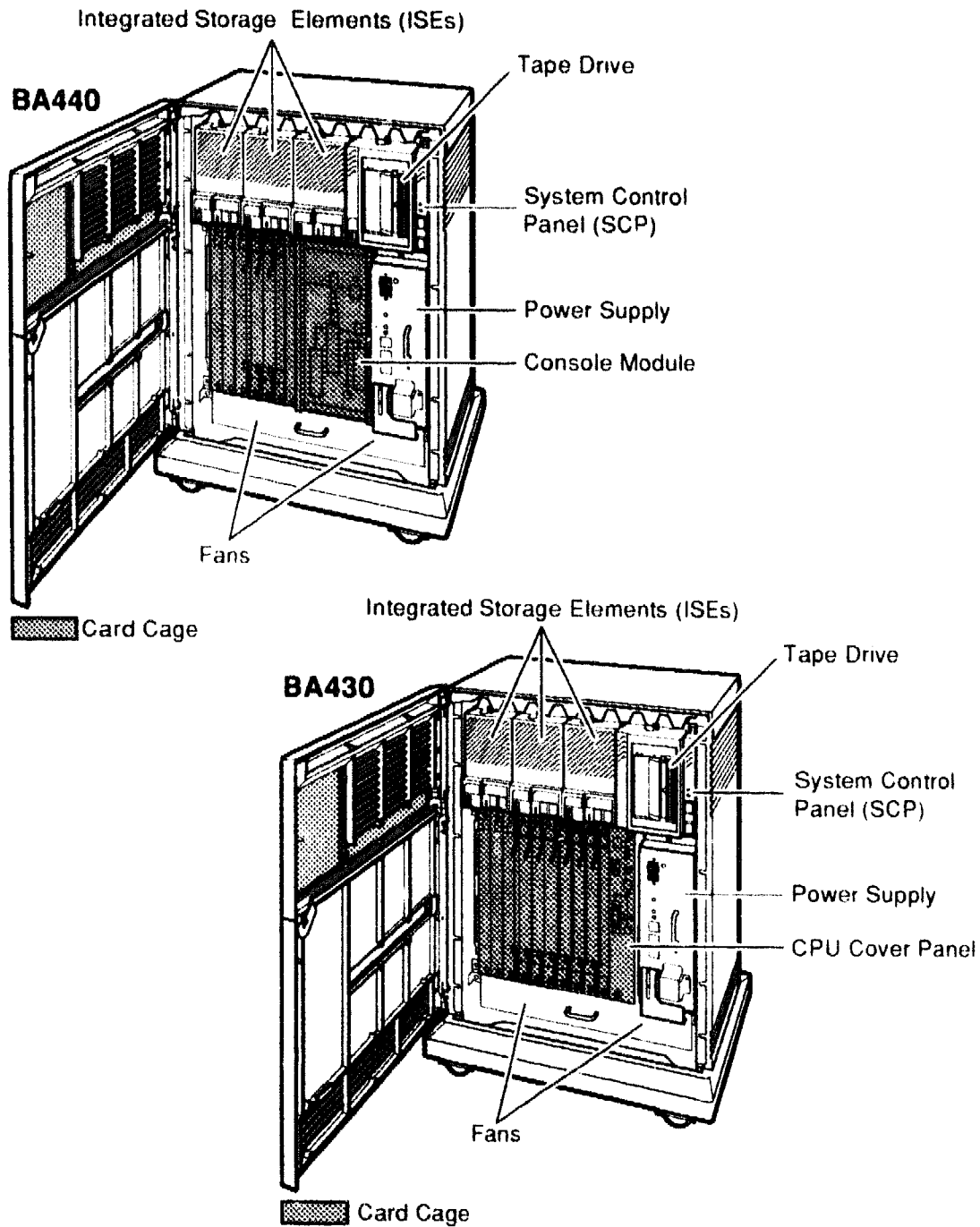

MLO-006698

## 1.2 Enclosure Keylock Access

The setting of a three-position lock (Figure 1-2) on the BA430 and BA440 enclosures (hereafter referred to as BA400-series enclosures) determines which controls you can access. The level of access is as follows:

1. Top position opens the upper door, provides access to only the operator control panel and the ISE and tape drive controls.
2. Middle position locks both doors, access is not provided to any controls.
3. Bottom position opens both doors together, provides access to all controls, including the system on/off switch.

**Figure 1-2: Keylock Positions**

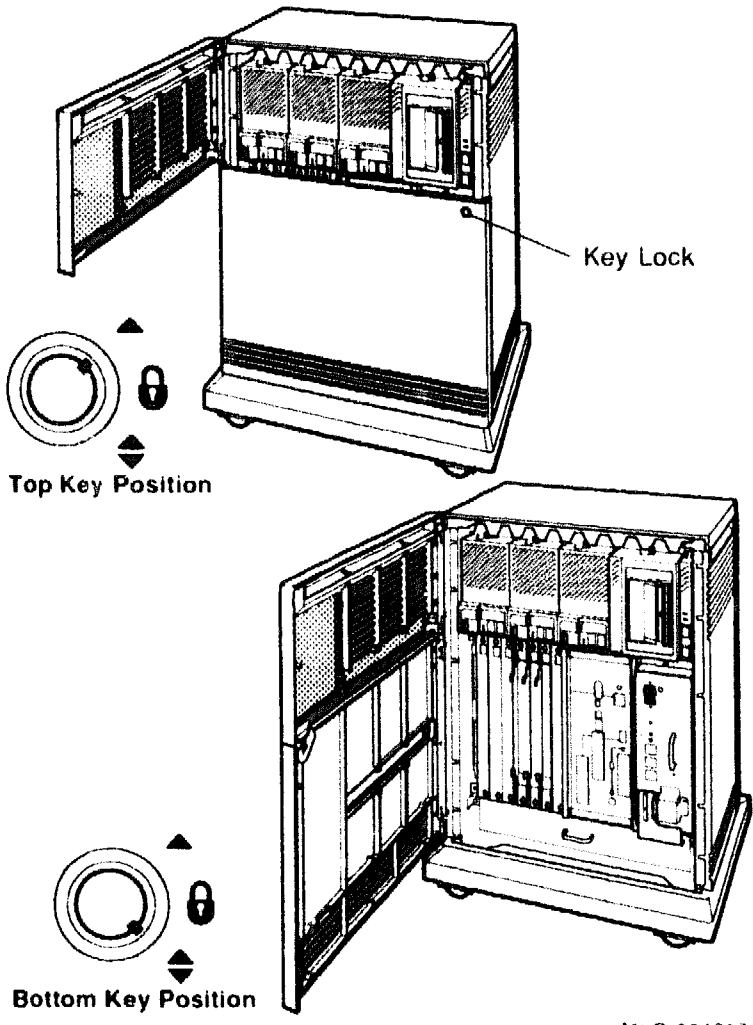

MLO 004207

## 1.3 Module Handles and Covers

The BA400-series enclosures provide front access to the CPU, memory, and option modules.

BA400-series modules have the following characteristics:

- Modules that connect to external devices have bulkhead handles with the I/O connectors on the handle. The handles replace the insert panels and internal cabling found in other enclosures. This design is easier to maintain since it eliminates problems caused by faulty internal cabling.
- Modules that do not have external I/O connections have blank bulkhead covers. The module behind the cover has handles or levers to aid in inserting and removing the module. An example of this is the ratchet used on the BA440 CPU/memory.

The module handles and blank covers form an electrical noise seal that complies with requirements for controlling electromagnetic interference (EMI) by:

- Containing radio frequency interference generated by the system.
- Keeping external radio frequencies from entering the enclosure.

The module handles and blank covers also help guarantee proper airflow.

**NOTE:** *Module covers and handles are required to meet international regulatory standards and to maintain proper cooling.*

Each handle or cover has two captive quarter-turn Phillips screws to hold to hold it in place.

The seven basic types of handles and covers, or panels, used for BA400-series compatible modules are:

- Single-width flush handle
- Single-width recessed handle
- Ratchet ejector handle (BA440 CPU and memory only)
- Single-width blank cover
- Double-width console module (BA430 only)
- Double-width blank cover
- Five-wide console module (BA440 only)

Some modules have special configurations, such as the BA440's H3604 console module, which is a hinged module cover that covers the CPU and four memory modules. The H3604 console module also provides an I/O connector for the CPU. Table 1-1 describes the common handle variations.

**Table 1-1: BA400-Series Module Handle and Cover Types**

| <b>Part</b>                  | <b>Description</b>  |
|------------------------------|---|
| Single-width recessed handle | The handle is riveted to the module. This style is the preferred handle for all BA200-series and BA400-series modules with external I/O connectors. The CXA16 and CXY08 communication modules use this type of handle.  |
| Single-width flush handle    | Used when a recessed handle would interfere with the module circuitry or I/O connector. The flush handle is also riveted to the module. If you install this type of handle to the left of a module with a recessed handle, you must add a metal filler panel (70-24071-01) to maintain EMI/RFI compliance.  |
| Ratchet ejector handle       | The BA440 CPU and memory modules are equipped with ratchet ejector handles that keep the right amount of tension against the backplane connector. This ratchet arrangement causes the CPU and memory to make tight contact with the backplane bus and provides better system reliability (BA440 CPU and memory only). These handles are then covered by the H3604 console module. |
| Single-width blank cover     | Covers a standard Q22-bus module that does not have external I/O connectors (for example, a TQK70). If you install this type of cover next to a module with a recessed handle, you must add a metal filler panel (70-24071-01) to maintain EMI/RFI compliance.  |
| Double-width blank           | Covers two standard Q22-bus module slots that do not have connectors. If you install this type of cover next to a module with a recessed handle, you must add a metal filler panel (70-24071-01) to maintain EMI/RFI compliance.  |

**Table 1-1 (Cont.): BA400-Series Module Handle and Cover Types**

| <b>Part</b>   | <b>Description</b>   |
|---|--|
| Double-width CPU cover (H3602-AA/AC)                | <p>The H3602-AA CPU cover attaches over the CPU and one memory module in the BA430 enclosure (VAX 4000 Model 200). The H3602-AC CPU cover attaches over the CPU and one memory module in the BA430 enclosure (DECsystem 5500).</p> <p>The H3602-AA/AC CPU covers interface with the CPU through a short ribbon cable that connects the CPU to the CPU cover.</p> |
| Hinged console module with I/O (H3604) (BA440 only) | <p>The H3604 console module is a hinged I/O panel that covers the CPU module and four memory modules. The H3604 console module interfaces with the CPU module through a short ribbon cable that connects the CPU and the H3604 console module.</p>   |

Ratchet ejector handles are used only with BA440 CPU and memory modules (Figure 1-3). To install a module with ratchet ejector handles:

1. Insert the module into the guide slot.
2. Position the ratchet ejector fingers into the latching slots at the top and bottom of the card cage chassis.
3. Press the ratchet levers in until the module is seated in the backplane (a reasonable feeling that the module fits tightly). The ratchet does not need to be seated completely. The ratchet handles provide a method of removing any slack that may exist between the module connector and the backplane.

**CAUTION:** *The module handle needs only to fit tightly. Too much force can damage the ratchet handle.*

**Figure 1-3: BA400-Series Module Handles and Covers**

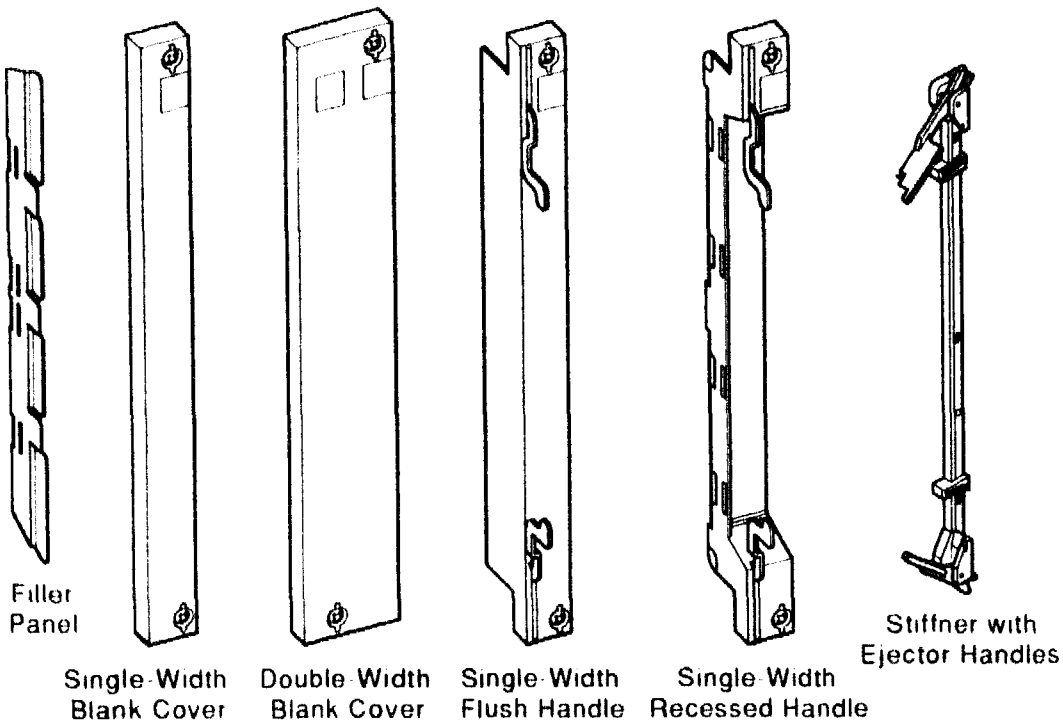

MLO-005413

### **1.3.1 Filler Panel Between Flush and Recessed Handles**

When you use a module cover next to, or a flush-handle module to the left of a recessed-handle module, you must install a metal filler panel (Figure 1-3) between the modules. Without the filler panel, circuitry on the module (a flush-handle module or a module under a cover) adjacent to the recessed-handle module is exposed. The filler panel (70-24071-01) has four sets of finger stock that provide an effective chassis ground between the handles. Flush handles have screw holes on top or bottom right side only, while covers have screw holes at the top and bottom of each side for the installation of this filler panel. Without the continuity provided by the filler panel, the system will not maintain EMI/RFI compliance.

## 1.4 Mass Storage Shelf

The BA430/BA440 enclosure has a mass storage shelf (Figure 1-4) that extends across the top of the enclosure. The shelf contains the System Control Panel (SCP) and may contain:

- EF-series ISEs
- RF-series ISEs
- RZ-series ISEs
- TK-series tape drive
- TF-series tape drive
- TLZ-series tape drive

**NOTE:** VAX 4000 systems do not support RZ-series ISEs.

**Figure 1-4: BA400-Series Chassis and Mass Storage Shelf**

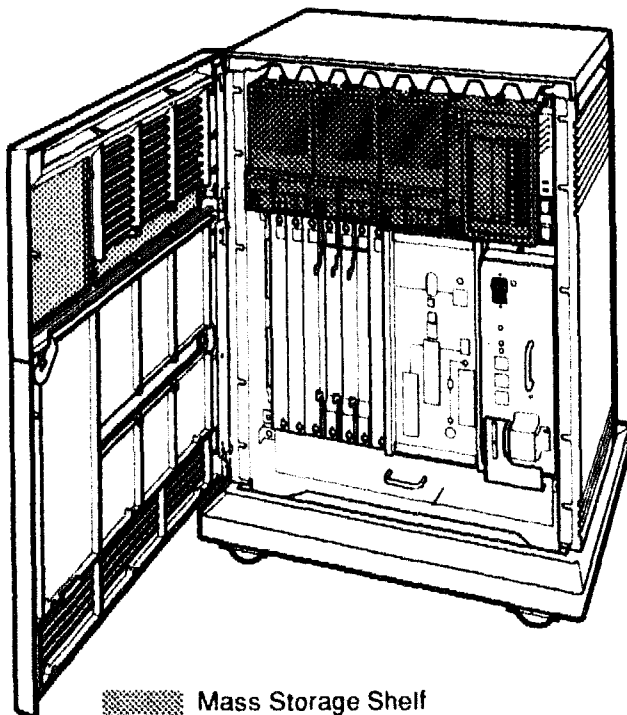

MLO-006704

**NOTE:** *Within a system enclosure it is possible to have up to seven disk storage devices, provided there is no tape drive in the enclosure. There can be three RF-series 3.5-inch dual storage devices and one 5.25-inch EF- RF- RZ-series storage device or a 3.5-inch single storage device.*

*A system can be configured with up to four 5.25-inch ISEs when a tape drive is not present or three 5.25-inch ISEs when a tape drive is present. ISEs are installed from right to left.*

## 1.5 EF-Series, RF-Series and RZ-Series ISEs

Figure 1-5 shows the 5.25-inch EF-series integrated storage elements (ISE). Figure 1-6 shows the 5.25-inch RF- and RZ-series ISEs. Figure 1-7 shows the 3.5-inch RF-series ISE configuration. The three types of ISEs vary as follows:

- 5.25-inch EF-series ISEs are solid state storage devices.
- RF- and RZ-series 5.25-inch ISEs contain only one storage device.
- RF-series 3.5-inch ISEs can contain two drives per ISE.

BA400-series ISEs contain hardware and a circuit module to allow the ISE to be plugged into the enclosure backplane.

**Figure 1-5: EF-Series 5.25-Inch ISE (Front and Rear View)**

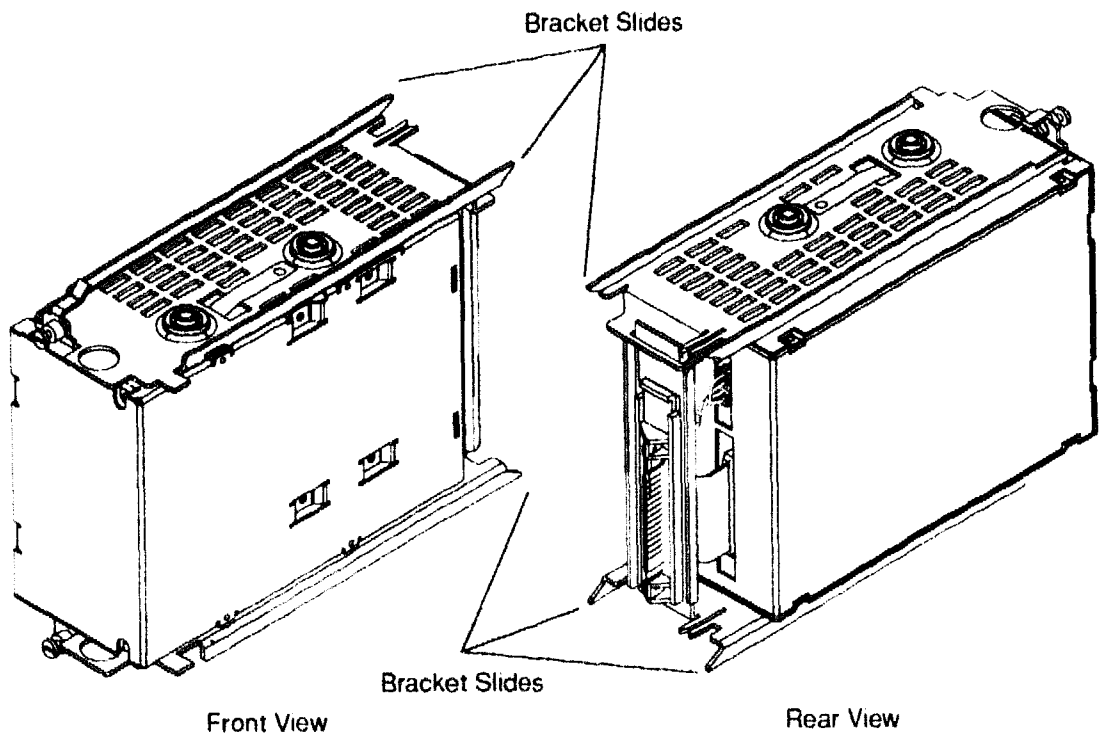

MLO-009301

**Figure 1-6: RF- and RZ-Series full height 5.25-inch ISE (Front and Rear View)**

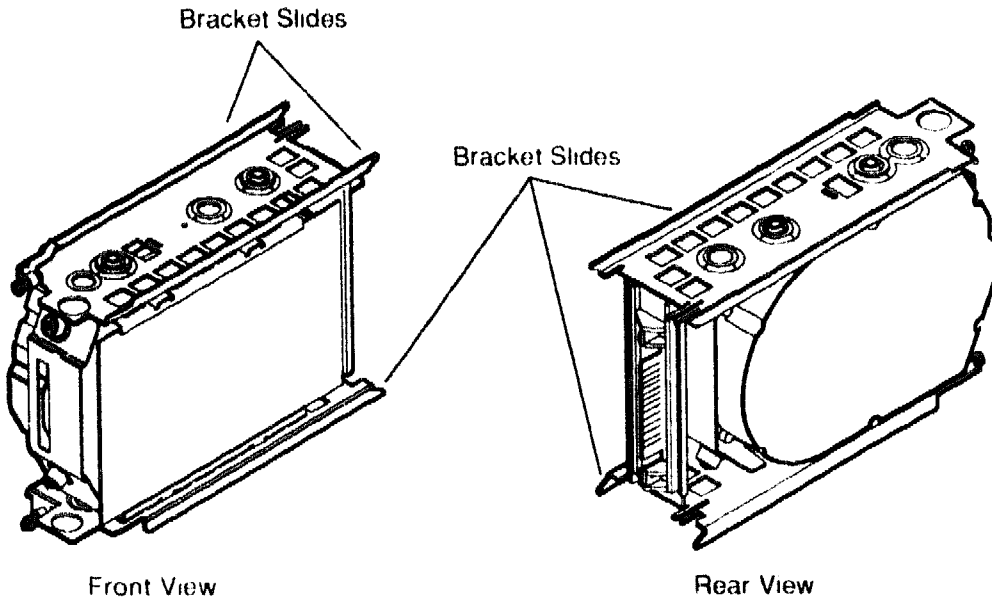

MLO 007239

**Figure 1-7: RF-Series 3.5-inch ISE Single Drive (Front and Rear View)**

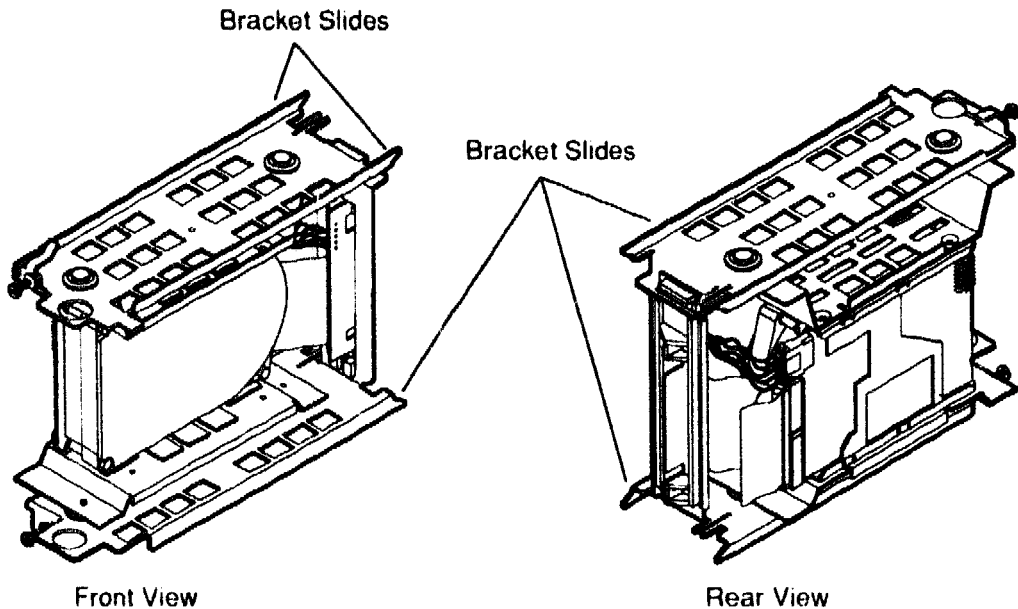

ML0-007240

Figure 1-5, Figure 1-6, and Figure 1-7, show the EF-series, RF-series, and RZ-Series with bracket slides. Bracket slides are mounted on the ISE for easier installation and removal.

ISEs, which are mounted from the front of the enclosure, contain shock-mounting hardware.

The term "integrated storage element" is used for any Digital Storage Systems Interconnect (DSSI) or Small Computer System Interface (SCSI) storage device. An ISE contains an on-board intelligent controller in addition to the drive and the control electronics.

The DSSI interface supports up to seven ISEs. DSSI interfaces can be embedded within a CPU module such as the KA670 module. They can also be separate modules, such as the KFQSA, which is interfaced by a single cable to a DSSI connector in the host enclosure.

EF-series ISEs are DSSI based solid state disk drives. There are two types of the EF-series ISE. One type includes an integrated Data Retention System (a 3 1/2-inch Winchester disk drive and a rechargeable battery) that provides non-volatility in the event of an AC power failure. The other is without a Data Retention System and has more memory modules, increasing the device's storage capacity.

RF-series ISE storage devices are based on the Digital Storage Architecture (DSA). The RF-series ISEs utilize the DSSI bus and interface.

RZ-series ISEs utilize the SCSI bus and interface. The SCSI interface supports up to seven ISEs. SCSI interfaces can be embedded within a CPU module such as the KN220 module. They can also be separate modules, such as the KZQSA which is connected by a single cable to a SCSI connector in the host enclosure or expander.

By convention the ISEs are numbered from right to left.

A spacer panel (70-27414-01) is used to fill the extra space when a disk ISE is installed in the right-most storage cavity.

Figure 1-8 shows the front panel assemblies:

**Figure 1-8: Front Panel Assemblies**

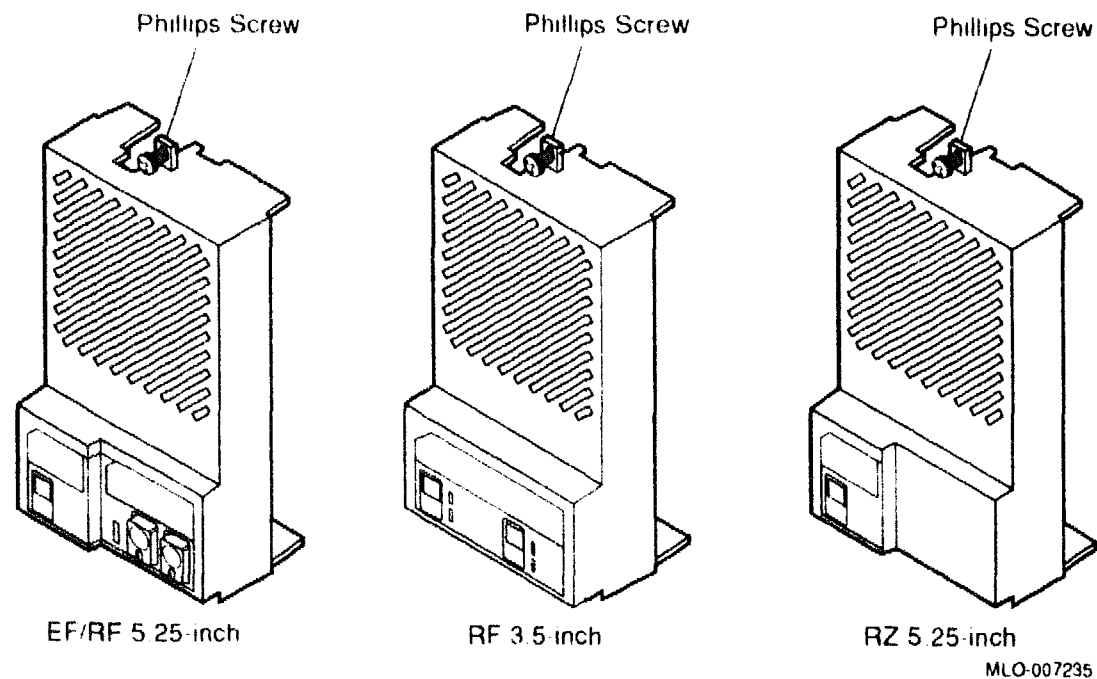

**NOTE:** The ISE front panel for RZ-series ISEs, unlike the front panel for EF-series and RF-series ISEs, has no buttons or indicators, only a plug for the bus node ID.

## 1.6 Tape Drives

Three types of tape drives can be installed in the right-most storage cavity:

- TF-series
- TK-series
- TLZ-series

The top right compartment of the BA430/BA440 enclosure can contain a TK-, TF-, or TLZ-series tape drive or another ISE such as an RF-series ISE (or RZ-series ISE in DECsystem 5500 only).

Figure 1-9: TF-Series Tape Drive

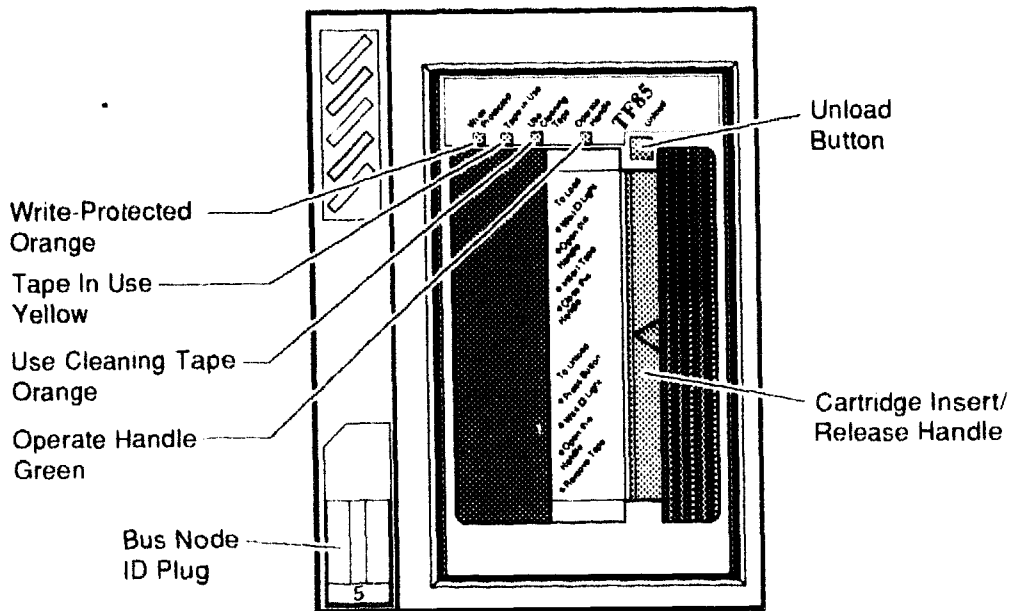

MLO 006543

**Figure 1-10: TK70 Tape Drive**

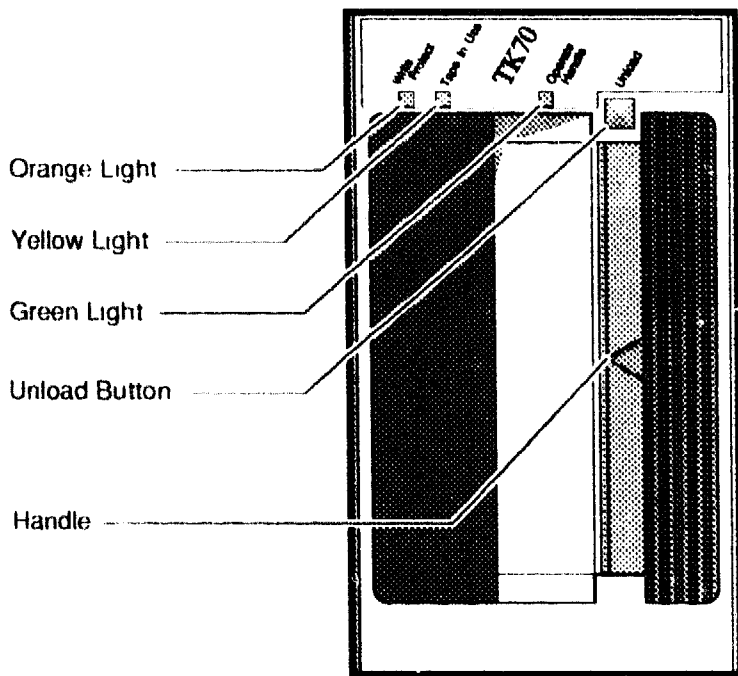

MLO-002292

**Figure 1-11: TLZ-Series Tape Drive**

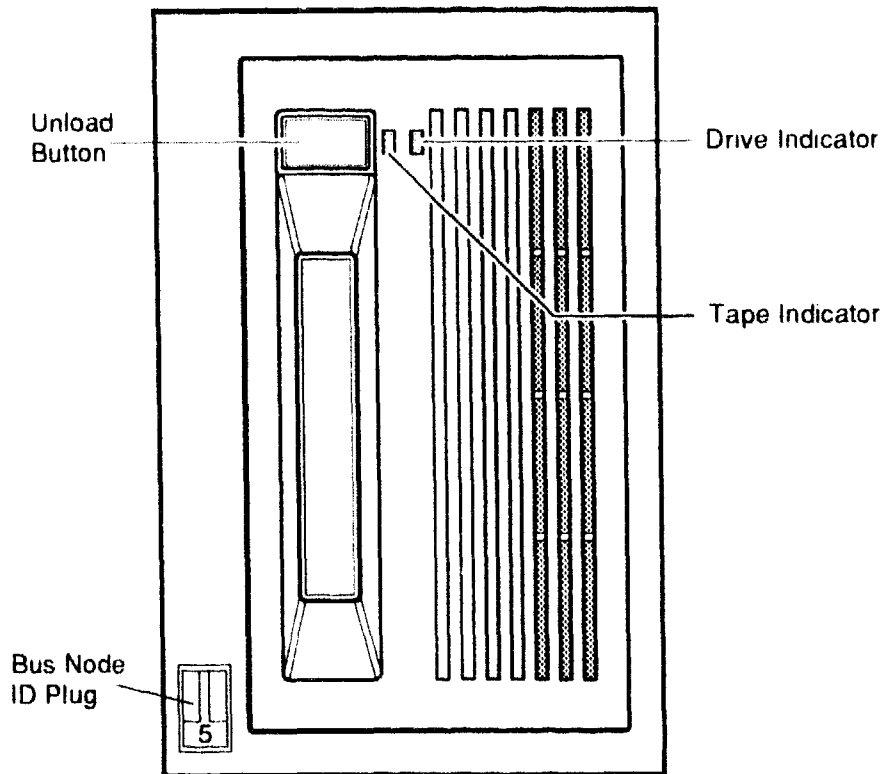

MLO 005538

## **1.7 System Control Panel (SCP)**

The BA430/BA440 SCP has the following indicators and buttons (Figure 1-12):

- Over Temperature Warning indicator
- DC OK indicator
- Halt button/indicator
- Restart button/Run indicator

**Figure 1-12: SCP Indicators**

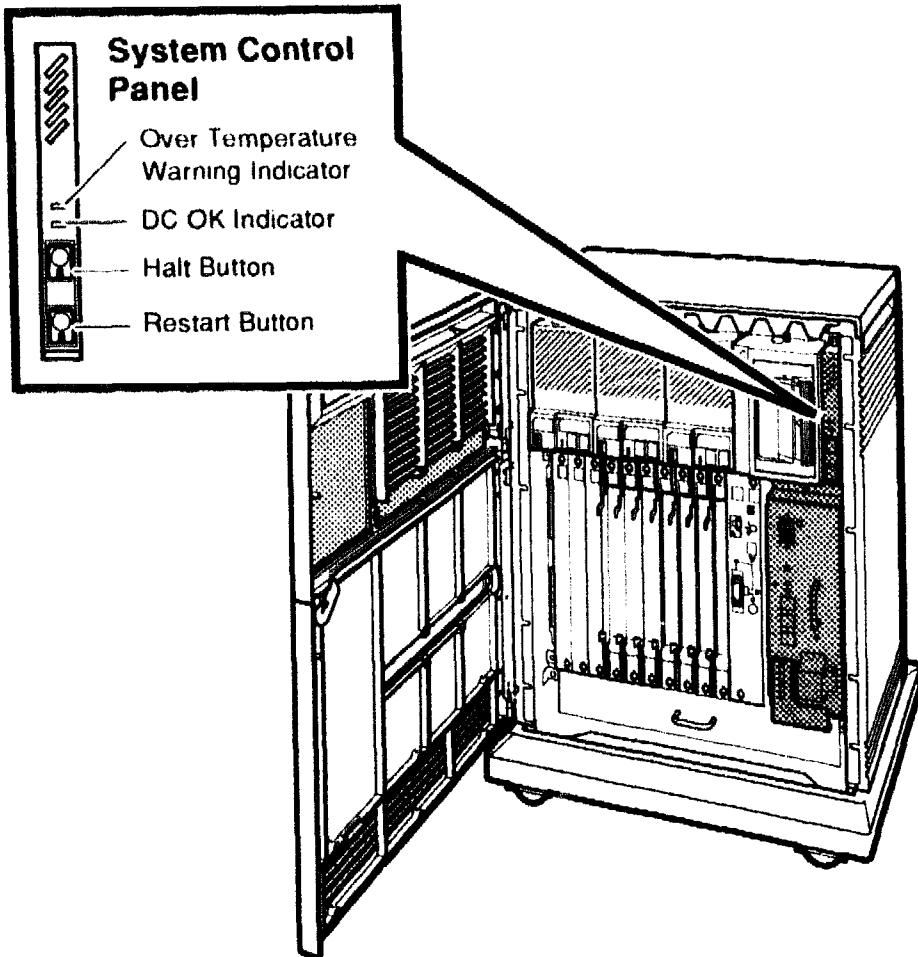

MLO 006620

**NOTE:** *The board behind the system's SCP contains switches that can be set to off to prevent accidental activation of the Halt and Restart buttons. See Figure 1-13.*

The Over Temperature Warning indicator lights when the system's internal temperature is approaching a level that may cause system components to overheat. If the internal temperature rises unacceptably, you will hear a pulsing sound and the Over Temperature Warning indicator will flash. The sound and visual marker are warning of a possible over temperature condition, before the system automatically shuts down. This feature allows time to take corrective action such as lowering the room temperature,

removing airflow obstructions, or performing an orderly system shutdown to prevent data loss.

The green DC OK indicator shows that the voltages are within the correct operating range. If the DC OK indicator is not lit when the system power is on, then a problem exists with the power supply.

Below the DC OK indicator is the two-position Halt button indicator. When the Halt button is pressed in, the system halts and the halt LED lights. Before you can enter console commands, you must press the button again to return it to the out position and display the console mode prompt (>>>). Now you can enter console commands. If you press the Halt button by mistake, type C and press Return to continue.

**CAUTION:** *Pressing the Halt button halts the system unconditionally, in spite of the setting of the Break Enable/Disable switch.*

The Restart/Run button is a momentary contact switch located below the Halt button/indicator. When pressed, the system returns to a run or reboot condition. If you have specified a device as the boot device and if the Break Enable/Disable switch is set to disable, the system will reboot the system software.

### **1.7.1 Enclosure Modification**

A system manager may request the following modifications to the SCP and fan speed control.

Switches located on the SCP board can be used to disable the SCP button functions. This could prevent accidental system shutdown if, for example, you were to leave the access doors open when training new people on the system. (See Section 1.7.2.)

When a system is located in an area where fan noise is more tolerable to users, the speed of the fans can be increased. This action allows a potential increase in system reliability, because the system components function more efficiently in a cooler environment. (See Section 1.10.1.)

### **1.7.2 Halt and Restart Switch Disable**

Four switches are located on the top rear of the system control panel. These switches, when positioned off, disable the Halt and Restart button functions on the SCP to protect the system from accidentally being halted or restarted. Figure 1-13 shows the location of the switch pack and Table 1-2 lists the switch functions. The factory configuration is always set to halt and restart enabled (switches on).

**Figure 1–13: SCP Enable/Disable Switch Location**

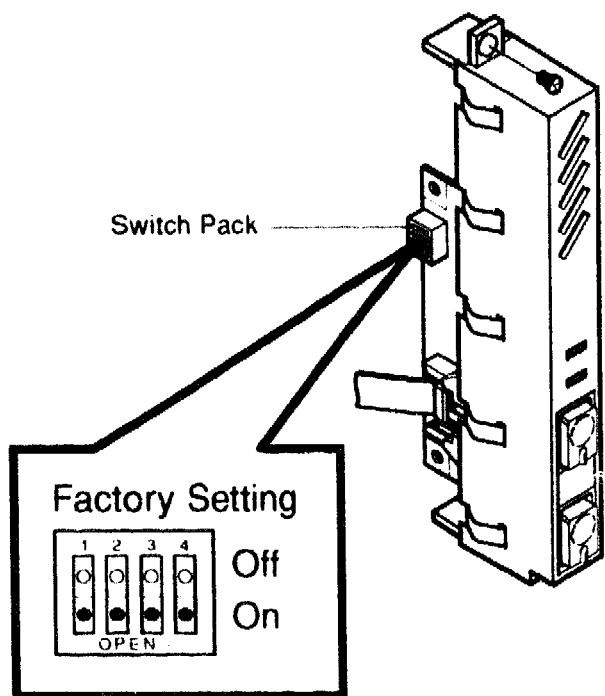

MLO-004203

**Table 1–2: SCP Switches and Functions**

| Switch | State | Function              |
|--------|-------|-----------------------|
| 1      | —     | Unused                |
| 2      | on    | Halt Switch Enable    |
| 3      | on    | Halt Indicator Enable |
| 4      | on    | Restart Switch Enable |

## 1.8 Enclosure Card Cage

The order of modules is different for the BA430 and the BA440 enclosures. The option modules are installed on the left side of the backplane. The following sections list the module arrangement for the BA430 and BA440 enclosures.

## 1.8.1 Components Specific to the DECsystem 5500 in a BA430 Enclosure

Table 1-3 lists modules for the DECsystem 5500 in the BA430 enclosure with their backplane slot locations. Figure 1-14 shows the DECsystem 5500 backplane.

**Table 1-3: DECsystem 5500 Module Order**

| Slot         | Module   |
|--------------|--|
| 0            | Interface module (M9715-AA)  |
| 1            | KN220 I/O module (M7638)   |
| 2            | KN220 CPU module (M7637)   |
| 2 and 3      | Console module (H3602-AC) covers the KN220 CPU module and one memory module. |
| 3            | Memory   |
| 4 through 6  | Three optional memory slots or option slots                                  |
| 7 through 12 | Option slots   |

**Figure 1-14: BA430 Enclosure Backplane (DECsystem 5500)**

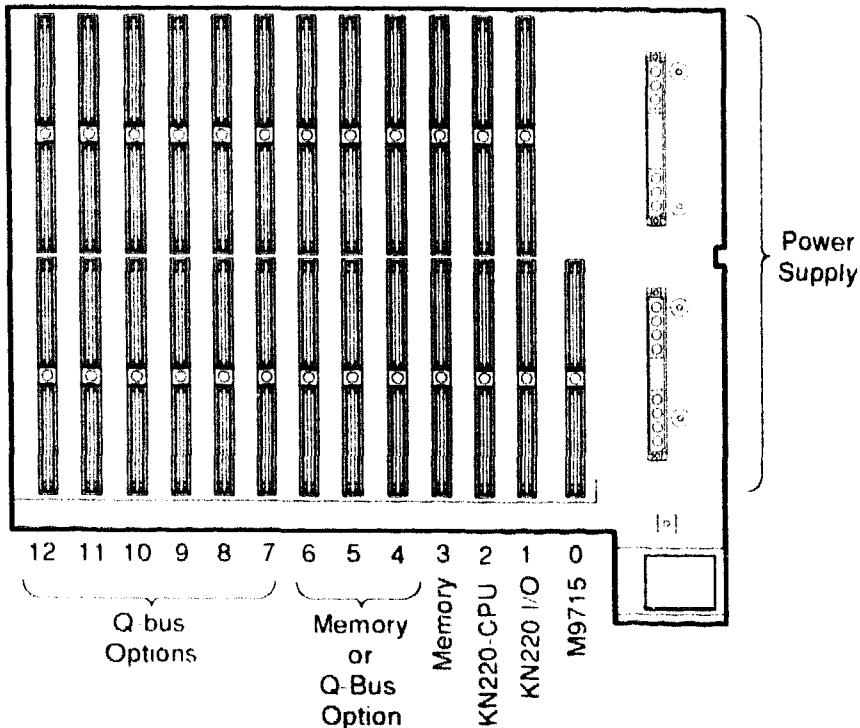

MLO-006621

### 1.8.1.1 H3602-AC CPU Cover Panel Used in the DECsystem 5500

The H3602-AC CPU cover panel is used on the BA430 enclosure (DECsystem 5500 only). This panel covers backplane slots 2 and 3 (Figure 1-15). The H3602 cover panel connects by cable to the CPU module behind it. The H3602 console module allows the CPU to interface to a serial-line console device, and to the Ethernet (with the use of either a ThinWire BNC connector or a standard Ethernet 15-pin transceiver connector).

See Table 1-7 for more information about the H3602.

### 1.8.1.2 H3605 I/O Panel Used in the DECsystem 5500

The H3605 I/O panel is installed over slot 1 and contains two SCSI I/O connectors (Figure 1-15).

**Figure 1-15: H3602-AC CPU Cover and H3605 I/O Panel, Used In DECsystem 5500**

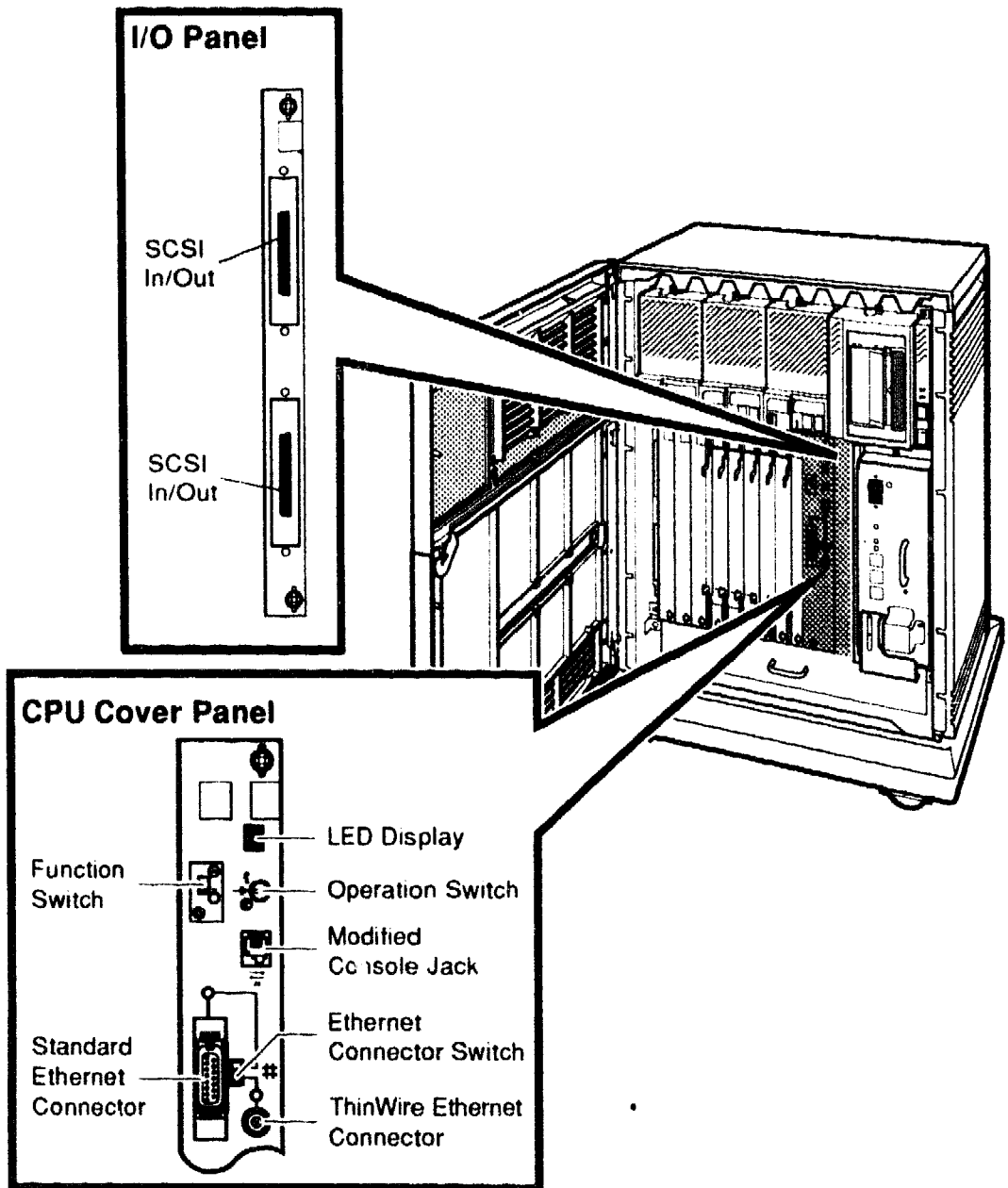

M.L.O-006622

### 1.8.1.3 M9715 Backplane Interface Module

The M9715-AA interface module is located on the extreme right, next to the power supply (backplane slot 0). The M9715 Module provides terminator power for both the DSSI and SCSI busses. Slot 0 is a dedicated dual C/D backplane slot on the Q22-bus (J24). The M9715 interface module is covered by a bulkhead panel that is required to maintain electromagnetic shielding.

## 1.8.2 Components Specific to VAX 4000 Model 200 System in a BA430 Enclosure

Table 1-4 lists modules in the VAX 4000 system in a BA430 enclosure with their backplane slot locations. Figure 1-16 shows the VAX/VAXserver 4000 Model 200 backplane.

**Table 1-4: VAX 4000 Model 200 (BA430) Module Order**

| Slot         | Module   |
|--------------|--|
| 0            | Interface module (M9715-AA)  |
| 1            | KA660 CPU module (M7626)   |
| 2            | Memory   |
| 1 and 2      | Console module (H3602-AA) covers the CPU module and one memory module slots. |
| 3 through 5  | Three optional memory slots or option slots                                  |
| 6 through 12 | Option slots   |

**Figure 1-16: BA430 Enclosure Backplane (VAX 4000 Model 200 System)**

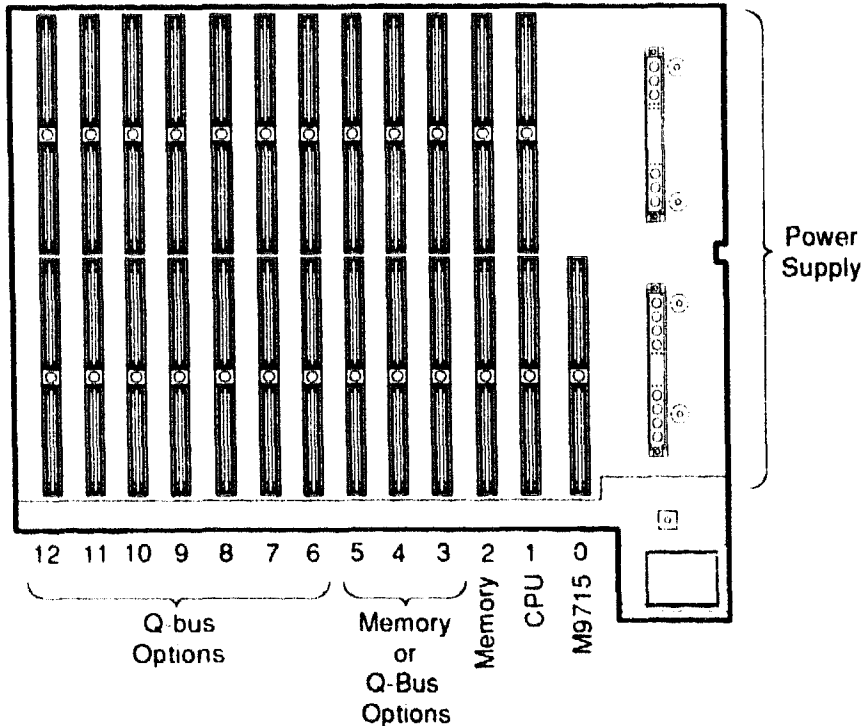

MLO-006523

### 1.8.2.1 H3602-AA CPU Cover Panel Used in VAX 4000 Model 200 (BA430 Only)

The H3602-AA CPU cover panel (Figure 1-15) is used on the BA430 enclosure for the VAX 4000 Model 200 system. This panel covers backplane slots 1 and 2. The H3602 cover panel connects by cable to the CPU module behind it. The H3602 console module allows the CPU to interface to a serial-line console device, and to the Ethernet (with the use of either a ThinWire BNC connector or a standard Ethernet 15-pin transceiver connector).

See Table 1-7 for more information about the H3602.

### 1.8.2.2 M9715 Backplane Interface Module

The M9715-AA interface module is located on the extreme right, next to the power supply (backplane slot 0). The M9715 Module provides terminator power for both the DSSI and SCSI busses. Slot 0 is a dedicated dual C/D backplane slot on the Q22-bus (J24). The M9715 interface module is covered by a bulkhead panel that is required to maintain electromagnetic shielding.

### 1.8.3 Components Specific to VAX/VAXserver 4000 Models 300, 500, and 600 in a BA440 Enclosure

Table 1-5 lists modules in the BA440 enclosure with their backplane slot locations. Figure 1-17 shows the BA440 backplane.

**Table 1-5: BA440 Module Order**

| Slot         | Module   |
|--------------|--|
| 1 through 4  | Memory modules   |
| 5            | CPU module   |
| 1 through 5  | Console module (H3604) covers the CPU module and four memory module slots. |
| 6 through 12 | Option slots   |

**Figure 1-17: BA440 Enclosure Backplane**

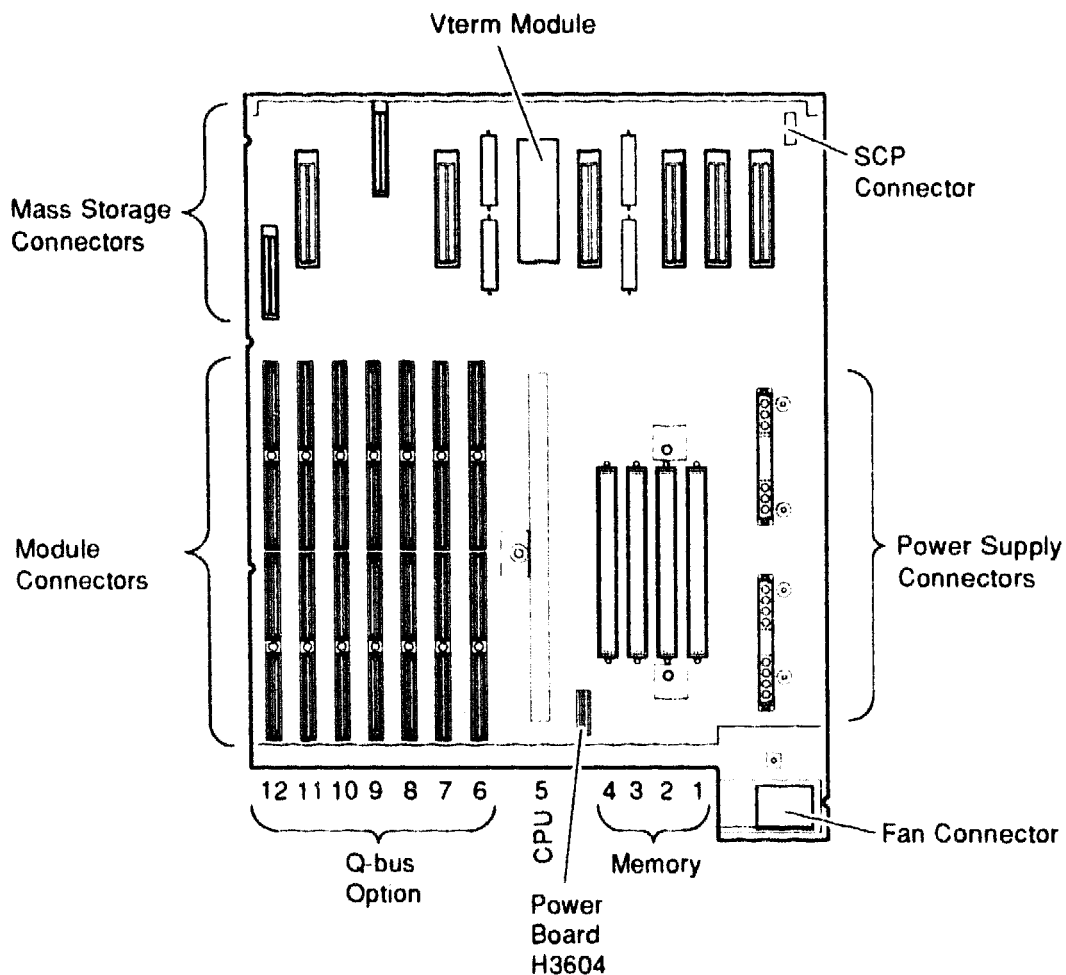

MLO-007695

### 1.8.3.1 H3604 Console Module (Used in BA440 Enclosure)

The H3604 console module is a multi-function module that covers the CPU and four memory locations. The four memory modules occupy the first four slots. The CPU occupies the fifth slot.

The H3604 console module allows the CPU to interface to a serial-line console device, devices on DSSI bus 1, and to the Ethernet (with the use of either a ThinWire BNC connector or a standard Ethernet 15-pin transceiver connector). Figure 1-18 shows the front of the H3604 console module.

**Figure 1-18: H3604 Console Module (Front)**

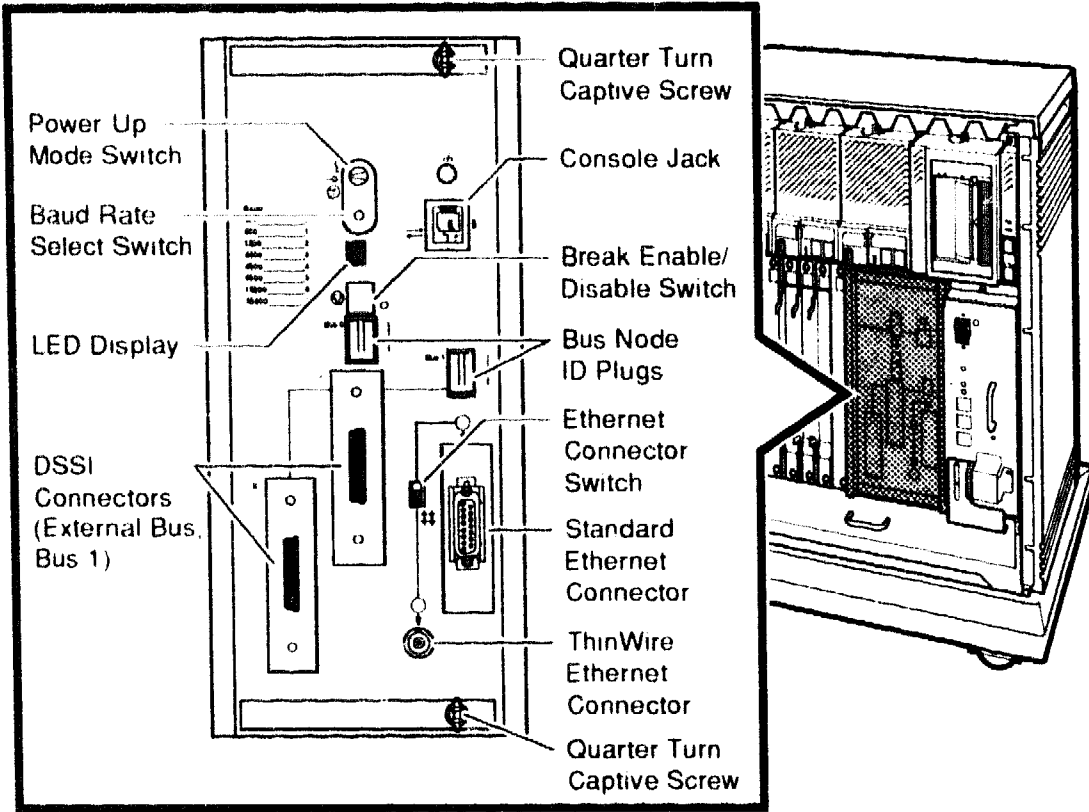

MLO-006350

Figure 1-19 shows the rear view of the H3604 console module and the location of the time of year (TOY) clock battery pack, fuses, and power connector.

**Figure 1-19: H3604 Console Module (Rear)**

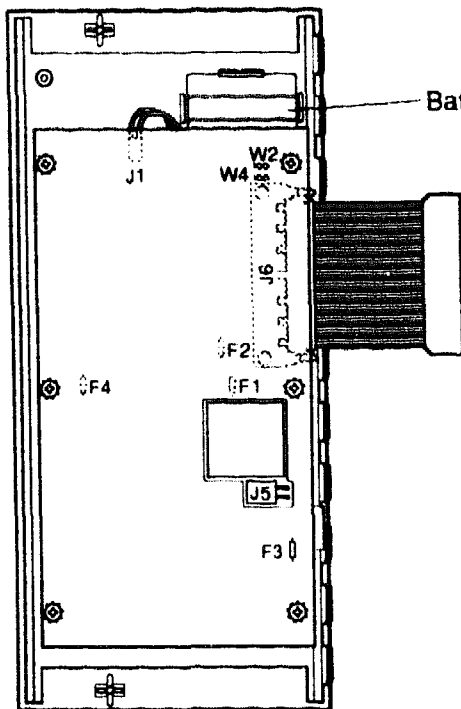

Battery Backup Unit

J1 = TOY Clock Battery  
J5 = H3604 Power  
J6 = CPU Interface  
W2 = Remote Boot Enable  
W4 = Not Used

F1 = ThinWire Ethernet Power, 0.5 A  
PN = 12-09159-00  
F2 = -12V Power, 0.062 A  
PN = 90-09122-00  
F3 = DSSI Terminator Power, 2.0 A  
PN = 12-10929-06  
F4 = Standard Ethernet Power, 1.5 A  
PN = 12-10929-08

MLO-006351

Table 1–6 lists the fuses, part numbers and symptoms of problems that may occur.

**Table 1–6: H3604 Console Module Fuses**

| <b>Fuse</b>        | <b>Part Number</b> | <b>Symptom</b>   |
|--------------------|--------------------|--|
| F1 (+12 V, 1/2 A)  | 12-09159-00        | ThinWire Ethernet LED on H3604 is not lit.<br><br>Ethernet external loop back test 5F fails if the Ethernet connector switch is set to ThinWire.   |
| F2 (-12 V, 1/16 A) | 90-09122-00        | No console display   |
| F3 (+5 V, 2 A)     | 12-10929-06        | LEDs on both DSSI terminators (Bus 1) on the H3604 console module are not lit; the DSSI terminator for Bus 0 is lit.<br><br>SHOW DSSI or SHOW DEVICE commands show DSSI bus 0, but console displays message indicating that DSSI bus 1 terminators are missing or not functioning.<br><br>DSSI SHAC (Bus 1) test 5C fails (countdown number 11). |
| F4 (+12 V, 1.5 A)  | 12-10929-08        | The LED on the loop back connector (12-22196-02) for standard Ethernet is not lit.<br><br>External loop back test 5F for the standard Ethernet passes, however.  |

Table 1-7 List the various controls, ports, and indicators that are available on the H3604 and H3602 console modules.

**Table 1-7: Controls, Ports, and Indicators Available on the H3604 and H3602 Console Modules**

| <b>Controls, Ports and Indicators</b>                          | <b>Console</b> |       |
|--|----------------|-------|
| 40-pin CPU module interface connector                          |                | H3602 |
| 100-pin CPU module interface connector                         | H3604          |       |
| Baud Rate Select switch  | H3604          | H3602 |
| Language Inquiry switch  | H3604          | H3602 |
| Hexadecimal display  | H3604          | H3602 |
| Break/Enable Disable switch                                    | H3604          | H3602 |
| Console serial MMJ connector                                   | H3604          | H3602 |
| DSSI terminator (fuse protected)                               | H3604          |       |
| TOY clock oscillator (25.6 KHz)                                | H3604          | H3602 |
| Two external (50-pin) DSSI connectors (X = in/out, Y = in/out) | H3604          |       |
| Two DSSI bus node ID plugs                                     | H3604          |       |
| <b>Ethernet Port Features</b>                                  |                |       |
| Standard Ethernet connector (15-pin)                           | H3604          | H3602 |
| ThinWire Ethernet BNC connector                                | H3604          | H3602 |
| Standard/ThinWire select switch with indicator LEDs            | H3604          | H3602 |
| Ethernet serial transceiver chip (SIA)                         | H3604          | H3602 |
| Ethernet selection LEDs (2)                                    | H3604          | H3602 |
| -9 V DC/DC converter   | H3604          | H3602 |
| Fused current surge protection                                 | H3604          |       |

## 1.9 Power Supply (H7874)

Both the BA430 and BA440 enclosures contain a modular H7874 power supply. Switch and indicator functions are shown in Figure 1-20 and defined in Table 1-8. The power supply plugs into the backplane through two connectors.

The H7874 power supply delivers the following maximum current:

- 22 amperes at +12.1 Vdc
- 60 amperes at +5 Vdc
- 15 amperes at +3.3 Vdc
- 3 amperes at -12.1 Vdc

Figure 1-20: Power Supply Indicators

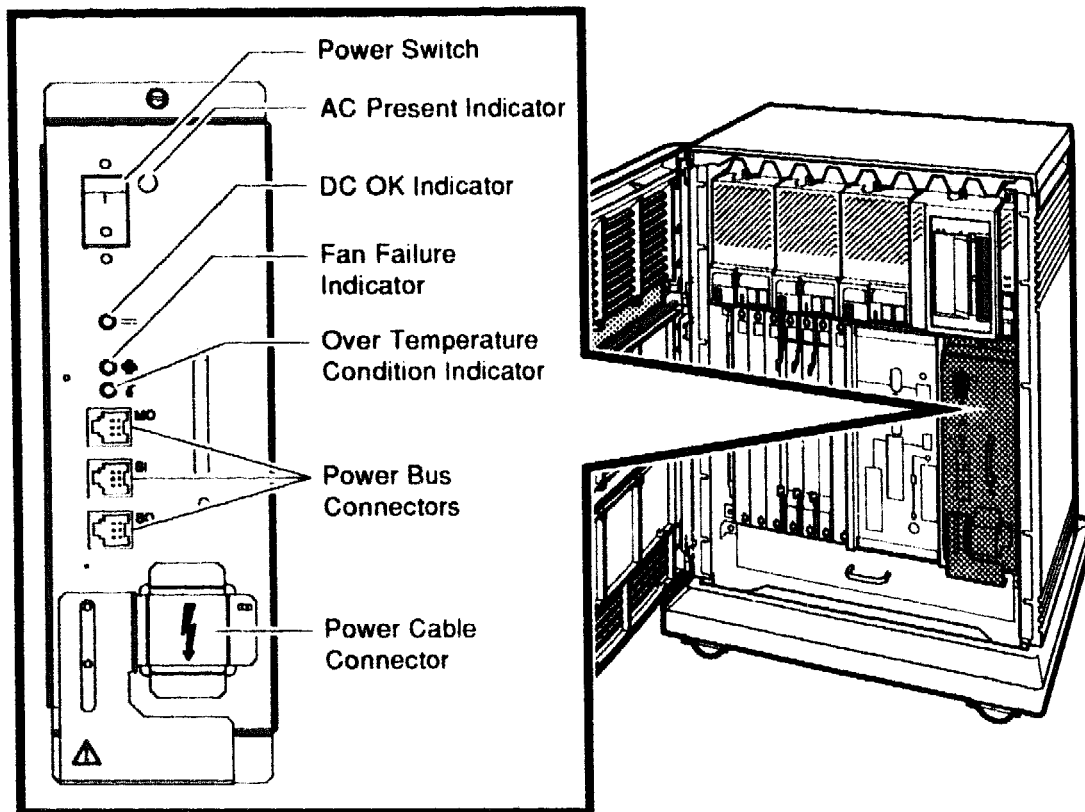

MLO 004040

The combined maximum loads on the +12.1 Vdc, -12.1 Vdc, +3.3 Vdc, and +5.1 Vdc must not exceed a total of 584 watts of power. The total output

power from the +3.3 Vdc and +5.1 Vdc must not exceed 330 watts. See the configuration worksheets in Figure 1–27 and Figure 1–28 for details .

The H7874 power supply has an AC Power switch and three power bus connectors for daisy-chained operation when used in a multi-enclosure configuration (Figure 1–21).

### 1.9.1 H7874 Power Supply Switches and Controls

The following table describes in detail the switches and controls of the H7874 power supply:

**Table 1–8: H7874 Power Supply Switches, Controls, and Indicators**

| <b>Control/Indicator</b>           | <b>Function</b>   |
|------------------------------------|---|
| AC Present indicator (orange)      | Lights when the power switch is set to on (1), and the AC voltage is present at the input of the power supply.  |
| Power switch                       | <p>The power switch is used to turn system power on and off. The off position is indicated by a 0; the on position is indicated by a 1.</p> <p>The power switch also functions as the system circuit breaker. In the event of a power surge, the breaker will trip causing the power switch to return to the off position (0). Turning on the system resets the circuit breaker. If the circuit breaker trips, wait one minute before turning the system back on.</p> |
| DC OK indicator (green)            | When the DC OK indicator is lit, the voltages are within the correct operating range. An un-lit DC OK indicator shows a problem with the power supply.  |
| Fan Failure indicator (amber)      | The Fan Failure indicator lights if either of the two cooling fans stops working. The power supply will automatically shut down the system as a precautionary measure when a fan failure is detected.   |
| Over Temperature indicator (amber) | The Over Temperature indicator lights if the system has shut down due to an over temperature condition.   |

**Table 1-8 (Cont.): H7874 Power Supply Switches, Controls, and Indicators**

| <b>Control/Indicator</b> | <b>Function</b>  |
|--------------------------|--|
| Power bus connectors     | <p>Three power bus connectors allow you to configure a power bus for expanded systems. The power bus allows you to turn power on and off for the expanded system through one power supply designated as the main expanded power supply: this way, one power switch can control power for an expanded system. Figure 1-21 illustrates a possible power bus configuration.</p> <p><b>NOTE:</b> <i>Dual-host systems should not be configured with a power bus. Inadvertently shutting off a host system and bringing down the cluster defeats the added reliability of a dual-host system.</i></p> |
| MO                       | <p>The Main Out connector sends the power control bus signal to the expander. One end of a power bus cable is connected here; the other end is connected to the SI (secondary in) connector of the expander power supply.</p>  |
| SI                       | <p>The Secondary In connector receives the power bus control signal from the main power supply. In a power bus with more than one expander, the power bus signal is passed along using the secondary in and secondary out connectors.</p>  |
| SO                       | <p>The Secondary Out connector sends the signal down the power bus for configurations of more than one expander. Figure 1-21 shows a sample of the power bus daisy-chain configuration.</p>  |

To add more secondary enclosures to the Power Control Bus (PCB), simply connect a PCB cable from the SO (Secondary Out) connector on the last unit currently in the chain to the SI (Secondary In) connector on the enclosure to be added. Up to four secondary enclosures may be daisy-chained from a main enclosure in this way. More than four secondary enclosures may be controlled by the PCB by connecting the MO (Main Out) connector on the fourth secondary enclosure to the SI connector on the fifth secondary enclosure. Enclosures can be cascaded in this manner to add an unlimited

number of secondary enclosures to a system. No termination is needed for the PCB.

**Figure 1-21: Sample Power Bus Configuration**

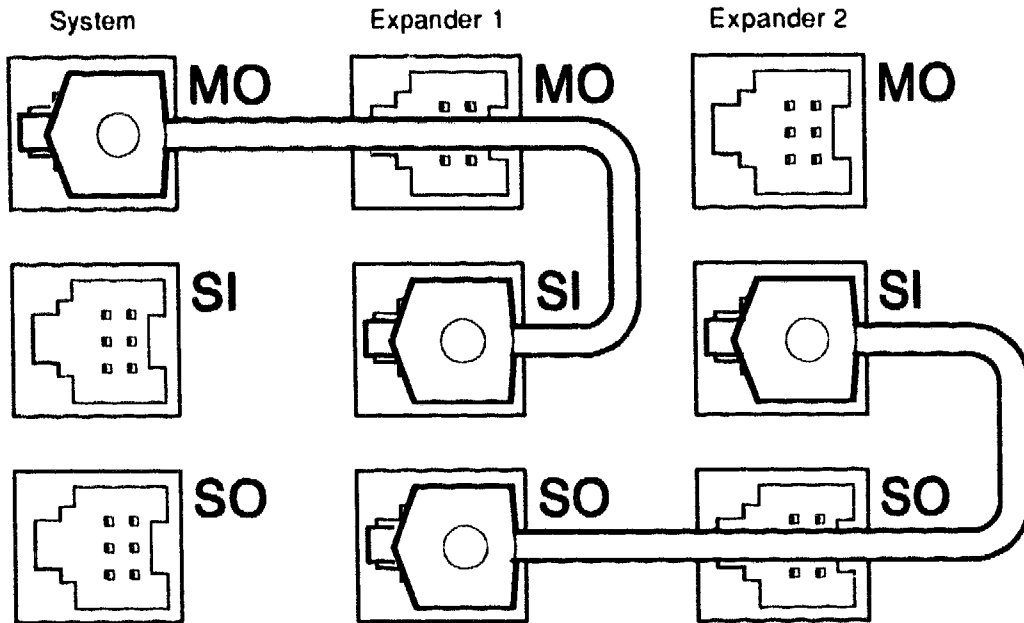

MLO-004041

**NOTE:** *The H7874 power supply automatically selects either 120 or 240 Vac when power is turned on.*

### 1.9.2 H7874 Shutdown Mode

The power supply enters and completes a shutdown sequence whenever the BPOK H signal is negated. When BPOK H is asserted high on the Q22-bus, the power system will allow normal system operation. The following conditions negate BPOK H:

- Temperature sensor triggered
- An over-current condition
- An over-voltage condition
- Loss of ac input
- Fan failure

- Input voltage greater than 132 Vrms or less than 88 Vrms (if in 120 Vrms mode) or input voltage greater than 264 Vrms or less than 176 Vrms (if in 240 Vrms mode)

## 1.10 Fan Tray

The BA430/BA440 enclosure has two 15-cm (6-in) dc fans located in a tray (Figure 1-22 and Figure 1-23) beneath the card cage area. Air is pulled in through the top of the enclosure and forced through the ISEs, power supply, and module options, and then expelled through the vents at the bottom, sides, and rear of the enclosure. A temperature sensor in the power supply adjusts the volume of air by varying the fan's speed based on the system's temperature. The input voltage to the fans varies between 10 Vdc and 20 Vdc, depending on the internal temperature of the power supply.

**Figure 1-22: BA430/BA440 Fan Tray Location**

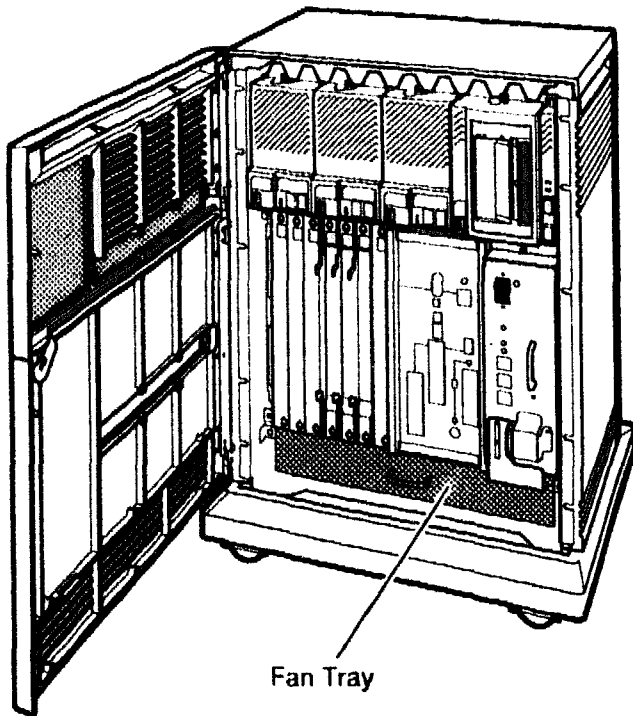

MLO-005357

**Figure 1-23: Fan Tray Extended**

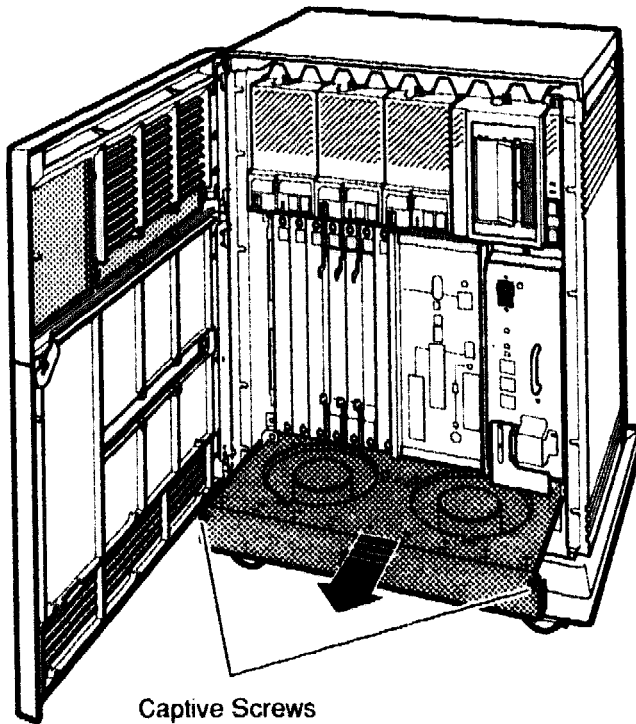

Captive Screws

MLO-004220

### **1.10.1 Fan Speed Control Disable**

Some system managers request that the enclosure fans run at the maximum rate at all times, to take advantage of a potential increase in system reliability. The system environment must not exceed the limits described in the *Site Preparation* manual. Figure 1-24 shows the location of the fan speed control (FSC) jumper.

## **1.11 Backplanes**

The BA430/BA440 enclosures have different backplanes. Backplane 54-20181-01 is used in the BA430 and backplane 54-19354-01 is used in the BA440 enclosure.

The BA430/BA440 enclosure supports 35 equivalent ac loads and 20 dc loads from all the modules installed in the backplane. An ac load is the amount of capacitance a module presents to a bus signal line. One ac load

**Figure 1-24: FSC Jumper Location**

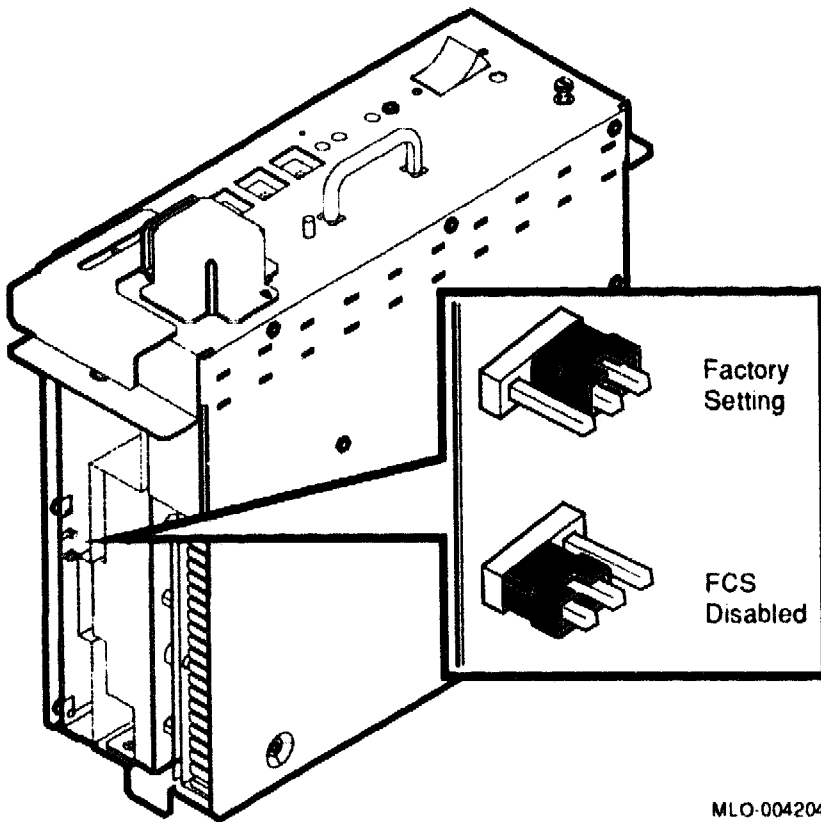

equals 9.35 picofarads (pf). A dc load is the amount of dc leakage current a module presents to a bus signal line. One dc load is approximately 105 microamperes ( $\mu\text{A}$ ). The backplane presents 4 ac loads to the Q22-bus. The Q-bus, for both BA430 and BA440 backplanes, can be extended by using an expander.

Connectors are provided for each of the following:

- Fan tray
- System control panel (SCP)
- Four mass storage compartments
- Power supply
- Vterm regulator module (BA440 only)
- Power Board for H3604 (BA440 only)
- CPU and memory slots
- Q-bus slots
- M9715-AA Interface Module (BA430 only)
- Internal SCSI cable connector
- Internal DSSI cable connector

### **1.11.1 BA430 Backplane**

This 40.7-cm x 52.1-cm (16.0-in x 21.0-in) 6-layer backplane, used in the BA430 enclosure, has 12 Q-CD backplane slots. The BA430 backplane, shown in Figure 1-25, contains connectors for DSSI and SCSI buses. Two main backplane power connectors near slot 1 interface with the power supply. Backplane connectors distribute power to module slots 1 through 12, to two 6-inch fans located at the bottom of the enclosure, to the System Control Panel (SCP), and to the four mass storage cavities.

**Figure 1-25: BA430 Backplane**

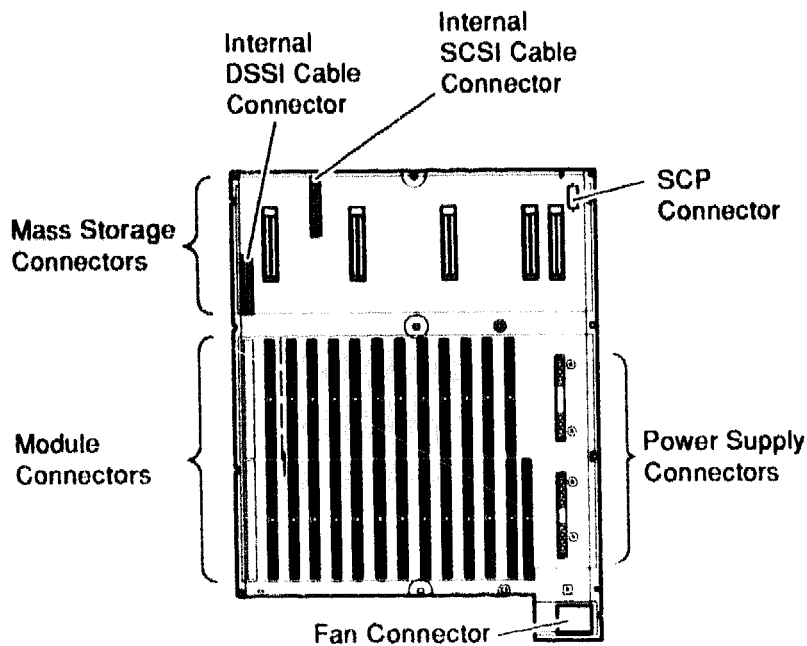

### 1.11.2 BA440 Backplane

The BA440 backplane, shown in Figure 1-26, is a 12-slot, quad-height backplane. The backplane is a 52.5-cm x 40.7-cm (21-in x 16-in) assembly. The space between each backplane slot varies. The backplane's printed circuit board is an 8-layer, 2-sided etch board. The BA440 backplane, shown in Figure 1-26, contains connectors for DSSI and SCSI buses. Two main backplane power connectors near slot 1 interface with the power supply. Backplane connectors distribute power to module slots 1 through 12, to two 6-inch fans located at the bottom of the enclosure, to the System Control Panel (SCP), and to the four mass storage cavities.

**Figure 1-26: BA440 Backplane**

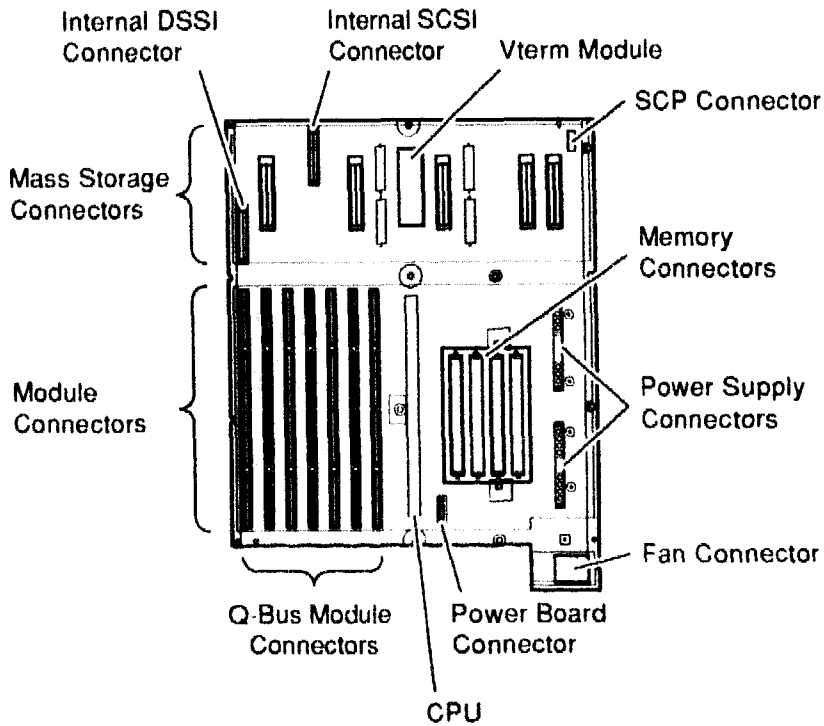

MLO-006353

## 1.12 Configuration Guidelines

Before changing the configuration of the BA430/BA440 enclosure, you must consider the following factors:

- Module order in the backplane
- Module configuration
- Mass storage device configuration

When adding a device to a system, you must know the capacity of the system enclosure in these areas:

- Backplane slots available
- Power supply capacity
- Mass storage slots available
- AC and DC loading
- Mass storage nodes available

### **1.12.1 Module Order and Configuration**

Module order in the backplane is specific to the CPU. Refer to the applicable CPU maintenance manual for the preferred module order of a given system.

For information on how to configure modules, refer to *Micro-systems Options*, which contains a listing of all supported options along with the following information for each module and device:

- Ordering information
- Operating System Support
- Diagnostic support
- Option description
- CSR addresses and interrupt vectors
- LEDs
- Loopback connectors
- Self-tests
- FRUs (if applicable)
- Related documentation

### **1.12.2 Configuration Worksheets**

Use Figure 1-27 or Figure 1-28 to be sure your configuration does not exceed system limits for expansion space, power, and bus loads. If you use standard Digital modules, you should not exceed the bus load limits.

When changing a configuration, choose the worksheet that applies to your system.

1. List all the devices already installed in the system.

2. List all the devices you plan to install in the system.
3. Fill in the information for each device, using the data listed in Table 1-9.
4. Add the columns. Make sure the totals are within the limits for the enclosure.

**NOTE:** *Check the CPU documentation to determine which options are supported for your system.*

**Figure 1-27: BA430 Configuration Worksheet**

| Slot                 | Module | Current (Amps) |         |          |         | Power (Watts) | Bus Load |    |
|----------------------|--------|----------------|---------|----------|---------|---------------|----------|----|
|                      |        | +5 Vdc         | +12 Vdc | +3.3 Vdc | -12 Vdc |               | AC       | DC |
| 0                    |        |                |         |          |         |               |          |    |
| CPU 1                |        |                |         |          |         |               |          |    |
| Mem 2                |        |                |         |          |         |               |          |    |
| Mem 3                |        |                |         |          |         |               |          |    |
| Mem 4                |        |                |         |          |         |               |          |    |
| Mem 5                |        |                |         |          |         |               |          |    |
| Q/CD 6               |        |                |         |          |         |               |          |    |
| Q/CD 7               |        |                |         |          |         |               |          |    |
| Q/CD 8               |        |                |         |          |         |               |          |    |
| Q/CD 9               |        |                |         |          |         |               |          |    |
| Q/CD 10              |        |                |         |          |         |               |          |    |
| Q/CD 11              |        |                |         |          |         |               |          |    |
| Q/CD 12              |        |                |         |          |         |               |          |    |
| <b>Mass Storage:</b> |        |                |         |          |         |               |          |    |
| Tape                 |        |                |         |          |         |               |          |    |
| 1                    |        |                |         |          |         |               |          |    |
| 2                    |        |                |         |          |         |               |          |    |
| 3                    |        |                |         |          |         |               |          |    |
| Total these columns  |        |                |         |          |         |               |          |    |
| Must not exceed      |        | 60.0 A         | 22.0 A  | 15.0 A   | 3.0 A   | 584.0 W       | 31       | 20 |

Note: Total output power from +3.3 Vdc and +5 Vdc must not exceed 330 W

MLO 005711

**NOTE:** +12 Vdc is 22.0 A, only if +3.3 Vdc is not used. Otherwise the value is 18.0 A.

**Figure 1-28: BA440 Configuration Worksheet**

| Slot                 | Module | Current (Amps) <sup>A</sup> |         |          |         | Power (Watts) | Bus Load |    |
|----------------------|--------|-----------------------------|---------|----------|---------|---------------|----------|----|
|                      |        | +5 Vdc                      | +12 Vdc | +3.3 Vdc | -12 Vdc |               | AC       | DC |
| MEM 1                |        |                             |         |          |         |               |          |    |
| MEM 2                |        |                             |         |          |         |               |          |    |
| MEM 3                |        |                             |         |          |         |               |          |    |
| MEM 4                |        |                             |         |          |         |               |          |    |
| CPU <sup>B</sup>     |        |                             |         |          |         |               |          |    |
| Q bus 1              |        |                             |         |          |         |               |          |    |
| Q bus 2              |        |                             |         |          |         |               |          |    |
| Q bus 3              |        |                             |         |          |         |               |          |    |
| Q bus 4              |        |                             |         |          |         |               |          |    |
| Q bus 5              |        |                             |         |          |         |               |          |    |
| Q bus 6              |        |                             |         |          |         |               |          |    |
| Q bus 7              |        |                             |         |          |         |               |          |    |
|                      |        |                             |         |          |         |               |          |    |
| <b>Mass Storage:</b> |        |                             |         |          |         |               |          |    |
| 1                    |        |                             |         |          |         |               |          |    |
| 2                    |        |                             |         |          |         |               |          |    |
| 3                    |        |                             |         |          |         |               |          |    |
| 4                    |        |                             |         |          |         |               |          |    |
|                      |        |                             |         |          |         |               |          |    |
| Total these columns  |        |                             |         |          |         |               |          |    |
| Must not exceed      |        | 60.0 A                      | 22.0 A  | 15.0 A   | 3.0 A   | 584.0 W       | 31       | 20 |

A. Total output power from +3.3 Vdc and +5 Vdc must not exceed 330 watts

B. Power requirements in this line include CPU module and H3604 console module

MLO-005361

**NOTE:** +12 Vdc is 22.0 A, only if +3.3 Vdc is not used. Otherwise the value is 18.0 A.

## 1.13 Power Requirements

Table 1–9 lists the power requirements for all options and modules that can be installed in the BA430/BA440 enclosures.

**Table 1–9: Power Requirements**

| Option             | Module   | Current (Amps)<br>(Max) |       | Power<br>(Max) | Bus Loads |     |
|--------------------|----------|-------------------------|-------|----------------|-----------|-----|
|                    |          | +5 V                    | +12 V | Watts          | AC        | DC  |
| AAV11-SA/SF        | A1009-PA | 2.10                    | 0.0   | 10.50          | 2.5       | 0.5 |
| ADQ32-SA/SF        | A030-PA  | 4.45                    | 0.0   | 22.25          | 2.5       | 0.5 |
| ADV11-SA/SF        | A1008-PA | 2.00                    | 0.0   | 10.0           | 2.3       | 0.5 |
| AXV11-SA/SF        | A026-PA  | 2.00                    | 0.0   | 10.0           | 1.2       | 0.3 |
| CXA16-AA/AF        | M3118-YA | 1.60                    | 0.20  | 10.40          | 3.0       | 0.5 |
| CXB16-AA/AF        | M3118-YB | 2.00                    | 0.0   | 10.00          | 3.0       | 0.5 |
| CXY08-AA/AF        | M3119-YA | 1.64                    | 0.40  | 12.94          | 3.0       | 0.5 |
| DESQLA-SA/SF       | M3127-PA | 2.40                    | 0.22  | 14.64          | 3.3       | 0.5 |
| DFA01-AA/AF        | M3121-00 | 1.97                    | 0.04  | 10.30          | 3.0       | 1.0 |
| DIV32-SA/SF        | M7571-00 | 5.5                     | 0.0   | 35.43          | 3.5       | 1.0 |
| DPV11-SA/SF        | M8020-YA | 1.20                    | 0.30  | 9.60           | 1.0       | 1.0 |
| DRQ3B-SA/SF        | M7658-PA | 4.50                    | 0.0   | 22.50          | 2.0       | 0.5 |
| DRV1J-SA/SF        | M8049-PA | 1.80                    | 0.0   | 9.00           | 2.0       | 1.0 |
| DRV1W-SA/SF        | M7651-PA | 1.80                    | 0.0   | 9.00           | 2.0       | 1.0 |
| DSV11-SA/SF        | M3108-PA | 5.43                    | 0.69  | 35.43          | 3.9       | 1.0 |
| EF51R-AA/AF        | -        | 0.0                     | 2.3   | 27.6           | N/A       | N/A |
| EF52R-AA/AF        | -        | 0.0                     | 2.3   | 27.0           | N/A       | N/A |
| EF53-AA/AF         | -        | 2.1                     | 0.0   | 10.5           | N/A       | N   |
| H3602              | -        | 0.30                    | 0.50  | 6.50           | 0.0       | 0.0 |
| H3604 <sup>1</sup> | -        | 1.70                    | 0.50  | 14.50          | 0.0       | 0.0 |
| IBQ01-SA/SF        | M3125-PA | 5.00                    | 0.30  | 28.60          | 4.6       | 1.0 |
| IEQ11-SA/SF        | M8634-PA | 3.50                    | 0.0   | 17.50          | 2.0       | 1.0 |

<sup>1</sup>Also include -12 Vdc @ 0.25 A, 3 W.

**Table 1-9 (Cont.): Power Requirements**

| Option                   | Module        | Current (Amps)<br>(Max) |       | Power<br>(Max) | Bus Loads |     |
|--------------------------|---------------|-------------------------|-------|----------------|-----------|-----|
|                          |               | +5 V                    | +12 V | Watts          | AC        | DC  |
| KA660-AA/BA <sup>2</sup> | M7626-AA/BA   | 4.8                     | 0.55  | 30.60          | 4.0       | 1.0 |
| KA670-AA/BA <sup>3</sup> | L4000-AA/BA   | 9.2                     | 0.5   | 52.0           | 4.0       | 1.0 |
| KA680-AA                 | L4002-BA      | 4.8                     | 1.6   | 53.8           | 4.0       | 1.0 |
| KA690-AA                 | L4002-AA      | 9.2                     | 0.5   | 52.0           | 4.0       | 1.0 |
| KDA50-SE/SG              | M7164-00      | 6.93                    | 0.0   | 34.65          | 3.0       | 0.5 |
|                          | M7165-00      | 6.57                    | 0.03  | 33.21          | 0.0       | 0.0 |
| KFQSA-SE/SG              | M7769-00      | 5.50                    | 0.0   | 27.50          | 4.4       | 0.5 |
| KLESI-SA/SF              | M7740-PA      | 4.00                    | 0.0   | 20.00          | 0.5       | 1.0 |
| KN220-AA                 | (CPU)M7637-AA | 13.75                   | 0.55  | 75.5           | 3.5       | 1.0 |
|                          | (I/O)M7638-AA |                         |       |                |           |     |
| KRQ50-SA/SF              | M7552-PA      | 2.70                    | 0.0   | 13.50          | 2.7       | 1.0 |
| KWV11-SA/SF              | M4002-PA      | 2.20                    | 0.01  | 11.16          | 1.0       | 0.3 |
| KXJ11-SA/SF              | M7616-00      | 6.0                     | 0.4   | 46.8           | 2.0       | 1.0 |
| KZQSA-SA/SF              | M5976-SA      | 5.5                     | 0.0   | 27.5           | 4.4       | 0.5 |
| LPV11-SA                 | M8086-YA      | 2.80                    | 0.0   | 14.00          | 1.8       | 0.5 |
|                          | M9404-PA      | 0.0                     | 0.0   | 0.0            | 0.0       | 0.0 |
|                          | M9405-PA      | 0.0                     | 0.0   | 0.0            | 0.0       | 0.0 |
| MRV11-D                  | M8578-00      | 1.60 <sup>4</sup>       | 0.0   | 8.00           | 3.0       | 0.5 |
| MS670-BA                 | L4001-BA      | 3.25                    | 0.0   | 16.25          | 0.0       | 0.0 |
| MS670-CA                 | L4001-CA      | 3.25                    | 0.0   | 16.25          | 0.0       | 0.0 |
| MS690-BA                 | L4004-BA      | 5.3                     | 0.0   | 26.5           | 0.0       | 0.0 |
| MS690-CA                 | L4004-CA      | 5.3                     | 0.0   | 26.5           | 0.0       | 0.0 |
| MS690-DA                 | L4004-DA      | 6.4                     | 0.0   | 32.0           | 0.0       | 0.0 |
| MS650-BA                 | M7622-AA      | 3.5                     | 0.0   | 17.5           | 0.0       | 0.0 |

<sup>2</sup> The KA660-AA/BA power requirements include power for the H3602 CPU cover panel.

<sup>3</sup> Also include 3.3 Vdc @ 15 A, 0.9 W and -12 Vdc @ 3.0 A, 0.5 W.

<sup>4</sup> Value is for the unpopulated module only.

**Table 1-9 (Cont.): Power Requirements**

| Option      | Module               | Current (Amps)<br>(Max) |       | Power<br>(Max) | Bus Loads |     |
|-------------|----------------------|-------------------------|-------|----------------|-----------|-----|
|             |                      | +5 V                    | +12 V | Watts          | AC        | DC  |
| MS650-BB    | M7622-BA             | 3.1                     | 0.0   | 15.5           | 0.0       | 0.0 |
| MS650-BC    | M7622-CA             | 2.8                     | 0.0   | 14.0           | 0.0       | 0.0 |
| MS220-AA    | M7639-AA             | 6.55                    | 0.0   | 31.0           | 0.0       | 0.0 |
| MS220-BA    | M7639-BA             | 6.55                    | 0.0   | 31.0           | 0.0       | 0.0 |
| RF31E-AA/AF | -                    | 1.2                     | 2.21  | 32.52          | N/A       | N/A |
| RF31F-AA/AF | -                    | 1.2                     | 2.21  | 32.52          | N/A       | N/A |
| RF31T-AA/AF | -                    | 0.76                    | 0.96  | 16.0           | N/A       | N/A |
| RF312-AA/AF | -                    | 1.52                    | 1.92  | 32.0           | N/A       | N/A |
| RF35E-AA/AF | -                    | 0.76                    | 0.96  | 16.0           | N/A       | N/A |
| RF352-AA/AF | -                    | 1.52                    | 1.92  | 32.0           | N/A       | N/A |
| RF71E-AA/AF | -                    | 1.25                    | 1.64  | 25.93          | N/A       | N/A |
| RF72E-AA/AF | -                    | 1.20                    | 1.75  | 27.0           | N/A       | N/A |
| RF73E-AA/AF | -                    | 1.2                     | 1.75  | 27.0           | N/A       | N/A |
| RZ56E-AA/AF | -                    | 1.36                    | 2.1   | 32.0           | N/A       | N/A |
| RZ57E-AA/AF | -                    | 1.36                    | 2.1   | 32.0           | N/A       | N/A |
| RZ58E-AA/AF | -                    | 1.0                     | 2.2   | 32.97          | N/A       | N/A |
| TF85E-JA/JF | -                    | 1.5                     | 2.4   | 36.30          | N/A       | N/A |
| TK50E-AA/AF | -                    | 1.5                     | 2.40  | 36.30          | N/A       | N/A |
| TK70E-AA/AF | -                    | 1.5                     | 2.40  | 36.30          | N/A       | N/A |
| TLZ04-JA/JF | -                    | 1.5                     | 2.4   | 36.3           | N/A       | N/A |
| TQK50-SA/SF | M7546-00             | 2.9                     | 0.0   | 14.5           | 2.8       | 0.5 |
| TQK70-SA/SF | M7559-00             | 3.50                    | 0.0   | 17.50          | 4.3       | 0.5 |
| TSV05-SA/SF | M7530-PA             | 6.50                    | 0.0   | 32.50          | 1.5       | 1.0 |
| VCB02-A     | M7615-00             | 4.6                     | 0.10  | 24.2           | 3.5       | 1.0 |
| VCB02-B     | M7168-00<br>M7169-00 | 8.85                    | 0.47  | 49.89          | 3.5       | 1.0 |

**Table 1-9 (Cont.): Power Requirements**

| Option  | Module                   | Current (Amps)<br>(Max) |       | Power<br>(Max) | Bus Loads |     |
|---------|--------------------------|-------------------------|-------|----------------|-----------|-----|
|         |                          | +5 V                    | +12 V | Watts          | AC        | DC  |
| VCB02-C | (2) M7168-00<br>M7169-00 | 12.0                    | 0.47  | 65.64          | 3.5       | 1.0 |

Each mass storage device receives power through an 80-pin connector located on the backplane. There is an interface module at the rear of the ISEs that plugs in directly to the backplane connector.

## Chapter 2

# Installation

---

This chapter contains the procedure for installing the BA430/BA440 pedestal enclosure.

### 2.1 Site Preparation

The following sections describe the various site needs for installing the BA430/BA440 pedestal enclosure.

#### 2.1.1 BA430/BA440 Physical Dimensions

Figure 2-1 shows the dimensions of the BA430/BA440 enclosure.

You must leave at least 61 cm (24 in) of clearance in front of the system to open the doors and access the system controls. You must also leave at least 5 cm (2 in) of clearance at the sides and rear for airflow. Because the base of the enclosure is 5 cm (2 in) wider than the cabinet in front and rear, you can place the rear of the system against a wall or table, and the system has enough space around it for adequate airflow.

**CAUTION:** *Due to the weight of the equipment, Digital recommends that at least two people move system and terminal boxes.*

**Figure 2-1: BA430/BA440 Enclosure Dimensions**

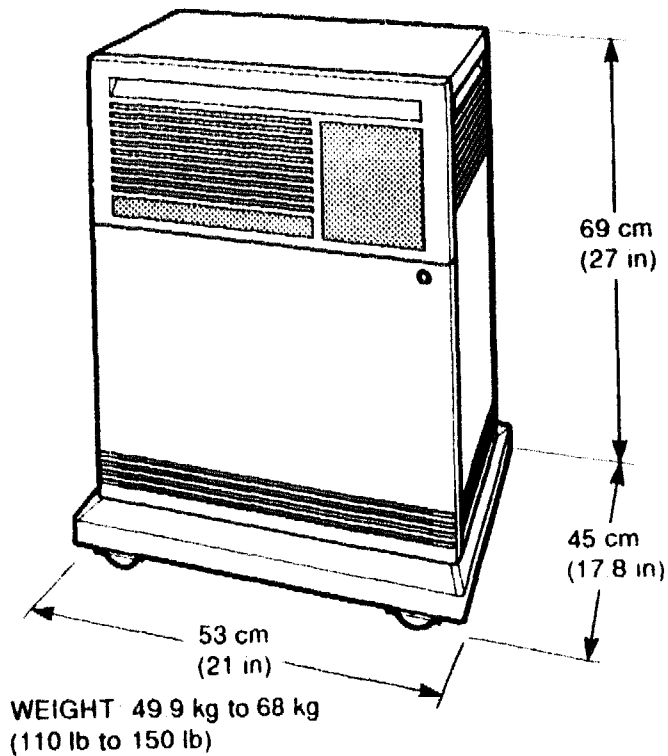

### 2.1.2 Additional Equipment

Make sure there is enough space for terminals and other peripheral equipment.

When you plan the cable routing for multi-terminal systems, consider factors such as safety, convenience, future expansion, and cost. Cabling should be in place and labeled before you install the system.

### 2.1.3 Static Electricity

Static electricity can cause system failure and loss of data. To minimize static build up, follow these guidelines:

- Maintain relative humidity of at least 40%.
- Place the system away from busy office corridors.

- Avoid using carpeting in the computer area, if possible. If carpeting is to be installed, recommend antistatic carpeting. If carpeting is already in place, place an antistatic mat under the system.
- Provide a separately-fed electrical circuit for each enclosure ordered (whether an expander or system).
- Provide as many electrical outlets as required for each additional device, including any tabletop device and console terminal.

### 2.1.4 Acoustics

The BA430/BA440 enclosure is designed for use in offices and other general working areas. Data is measured in accordance with ANSI S12.10-1985 (American National Standards Institute) and ISO/DIS 7779 (International Standards Organization).

- LNPE (B) is the noise power emission level (A-weighted sound power level) measured in bels per 1 pw (reference 1 picowatt). LNPE for the BA430/BA440 enclosure is 6.6 Bel.
- LPA is the sound pressure measured in decibels at 1.0 m from the front edge of the unit and 1.5 m above the floor. LPA for the BA430/BA440 enclosure is 61 decibels.

**NOTE:** *The actual noise level is dependent on the type and number of storage devices and may vary according to your configuration.*

### 2.1.5 Heat Dissipation

Heat dissipation is measured in British thermal units (Btu). Maximum heat dissipation in the BA430/BA440 enclosure is 2980 Btu/h.

### 2.1.6 Temperature and Humidity Values

Table 2-1 lists temperature and relative humidity values for the BA430/BA440 enclosure.

**Table 2-1: Temperature and Relative Humidity Values**

| Parameter                | Operating                     | Nonoperating                    |
|--------------------------|-------------------------------|---------------------------------|
| Temperature <sup>1</sup> | 10°C to 40°C<br>50°F to 104°F | -40°C to 66°C<br>-40°F to 151°F |

<sup>1</sup>For operation above sea level, decrease the operation temperature by 1.8°C per 1000 m (or 1 F per 1000 ft).

**Table 2-1 (Cont.): Temperature and Relative Humidity Values**

| <b>Parameter</b>           | <b>Operating</b>                               | <b>Nonoperating</b>         |
|----------------------------|--|-----------------------------|
| Temperature rate of change | 11°C per hour maximum<br>20°F per hour maximum | N/A                         |
| Relative humidity          | 20% to 80% (non-condensing)                    | 10% to 90% (non-condensing) |
| Maximum altitude           | 2438 m (8000 ft)                               | 4870 m (16,000 ft)          |

### 2.1.7 Electrical Requirements

The power source should be adequate to handle the original system and allow for system expansion. Digital recommends a dedicated circuit from the power source to each system. Additional power equipment may be required to avoid power disturbances.

Table 2-2 lists the electrical requirements for systems in a BA430/BA440 enclosure. Table 2-3 lists the power cables required.

**Table 2-2: BA430/BA440 Enclosure Electrical Requirements**

| <b>Nominal AC Voltage⇒</b>                      | <b>101 Vac</b> | <b>120 Vac</b> | <b>220 Vac</b> | <b>240 Vac</b> |
|---|----------------|----------------|----------------|----------------|
| Voltage range                                   | 90 to 110 Vac  | 104 to 128 Vac | 176 to 242 Vac | 186 to 264 Vac |
| Power source phase                              | Single         | Single         | Single         | Single         |
| Nominal frequency                               | 50 to 60 Hz    | 50 to 60 Hz    | 50 to 60 Hz    | 50 to 60 Hz    |
| Frequency range                                 | 47 to 63 Hz    | 47 to 63 Hz    | 47 to 63 Hz    | 47 to 63 Hz    |
| Maximum steady state current at nominal voltage | 11.9 A         | 11.2 A         | 6.1 A          | 5.8 A          |
| Startup current (30 seconds) at nominal voltage | 12.6 A         | 10.6 A         | 6.2 A          | 6.0 A          |
| Maximum inrush current                          | 100 A          | 100 A          | 83 A           | 83 A           |
| Maximum power consumption                       | 850 W          | 850 W          | 850 W          | 850 W          |

**Table 2-3: Power Cables**

| <b>Power Cables</b> | <b>Countries</b>                                       |
|---------------------|--|
| BN20A-2E            | United States, Japan, and Canada (17-00083-43 (120 V)) |

**Table 2-3 (Cont.): Power Cables**

| <b>Power Cables</b> | <b>Countries</b>   |
|---------------------|--|
| BN20B-2E            | United States, Japan, and Canada (17-00083-44 (240 V))   |
| BN22C-2E            | Australia and New Zealand  |
| BN22D-2E            | Central Europe, Austria, Belgium, Finland, France, Germany, Netherlands, Norway, Portugal, Spain, and Sweden |
| BN22E-2E            | United Kingdom and Ireland   |
| BN22F-2E            | Switzerland  |
| BN22H-2E            | Denmark  |
| BN22J-2E            | Italy  |
| BN22K-2E            | India  |
| BN22L-2E            | Israel   |

## 2.2 Unpacking the Shipment

The shipment may include several cartons:

- One contains the system unit.
- One contains cables for connecting additional devices to the system.
- Several contain components of the console terminal.
- Another, marked "Software", contains software documentation, system software, diagnostic software, and a software license.

**NOTE:** *Save all packing materials if you plan to reship the system.*

Depending on the order, the shipment may also include additional terminals, printers, or modems.

When delivered, the system is packed in a cardboard container attached to a shipping skid or pallet.

Before unpacking the equipment, check for external shipping damage. Report any damage to the customer's sales representative and contact the customer's delivery agent. Keep all packing material and receipts when filing a damage claim.

When you unpack the cartons, check the contents against the shipping list to ensure the order is complete.

Unpack the system according to the instructions on the system shipping carton.

After unpacking the system, move it by rolling it sideways or by sliding or walking it backward/forward while gripping the hand holds (Figure 2-2).

**WARNING:** *The system weighs between 50 kg (110 lb) and 68 kg (150 lb), depending on the options installed. Use two people to move the system.*

**Figure 2-2: Sliding the System into Place**

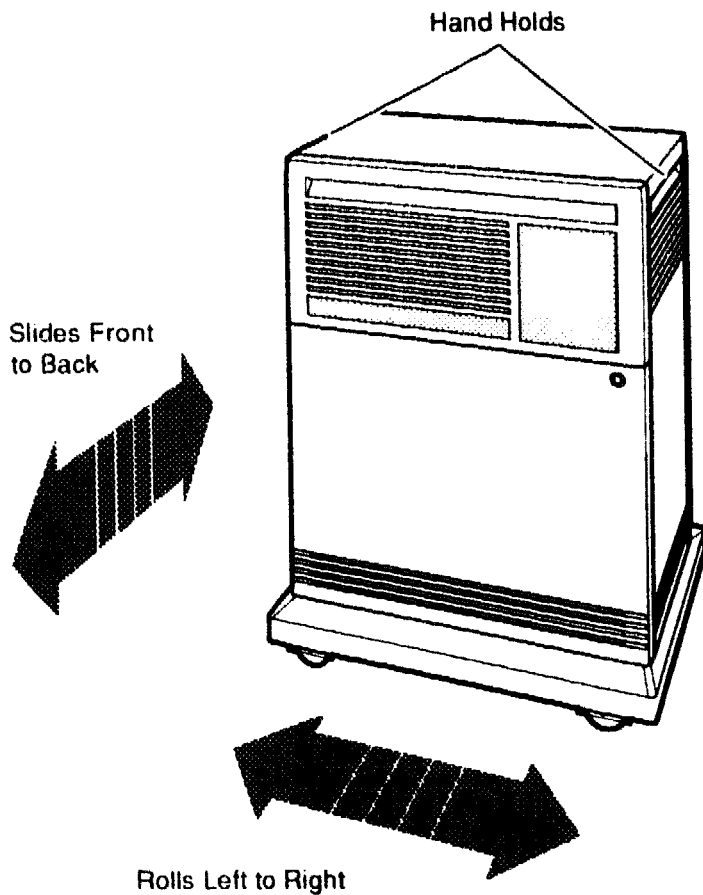

MLO 004012

During installation, leave a few inches behind the system for routing cables underneath the system unit. Once installation is complete, you can place the system base against a wall.

## 2.3 Connecting the Console Terminal

Install the console terminal to the BA430 as shown in Figure 2-3. Install the console terminal to the BA440 as shown in Figure 2-4.

Follow the instructions in the system *Installation* manual.

**Figure 2-3: Connecting the Console Terminal to the BA430**

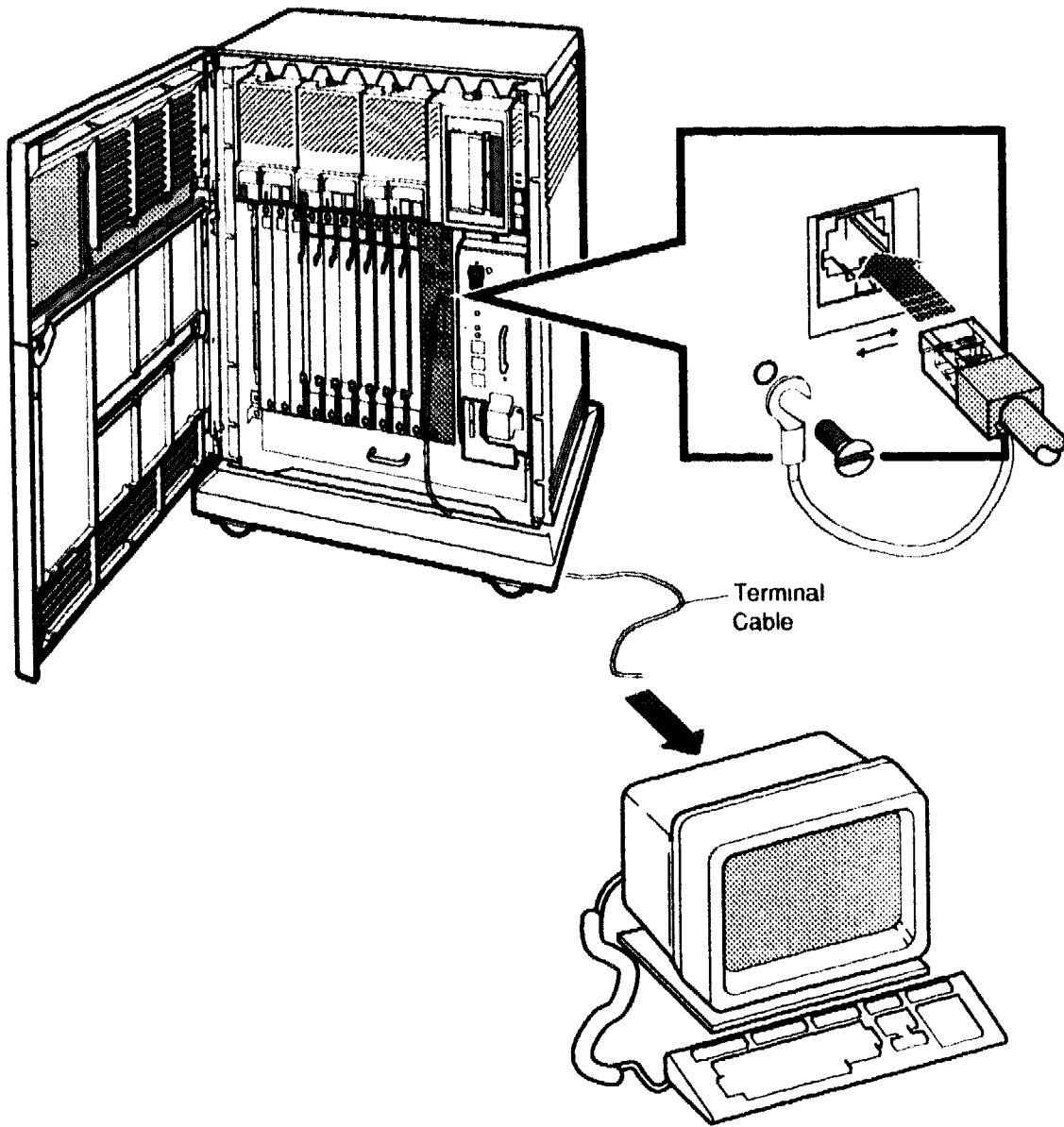

MLO-005562

**Figure 2-4: Connecting the Console Terminal to the BA440**

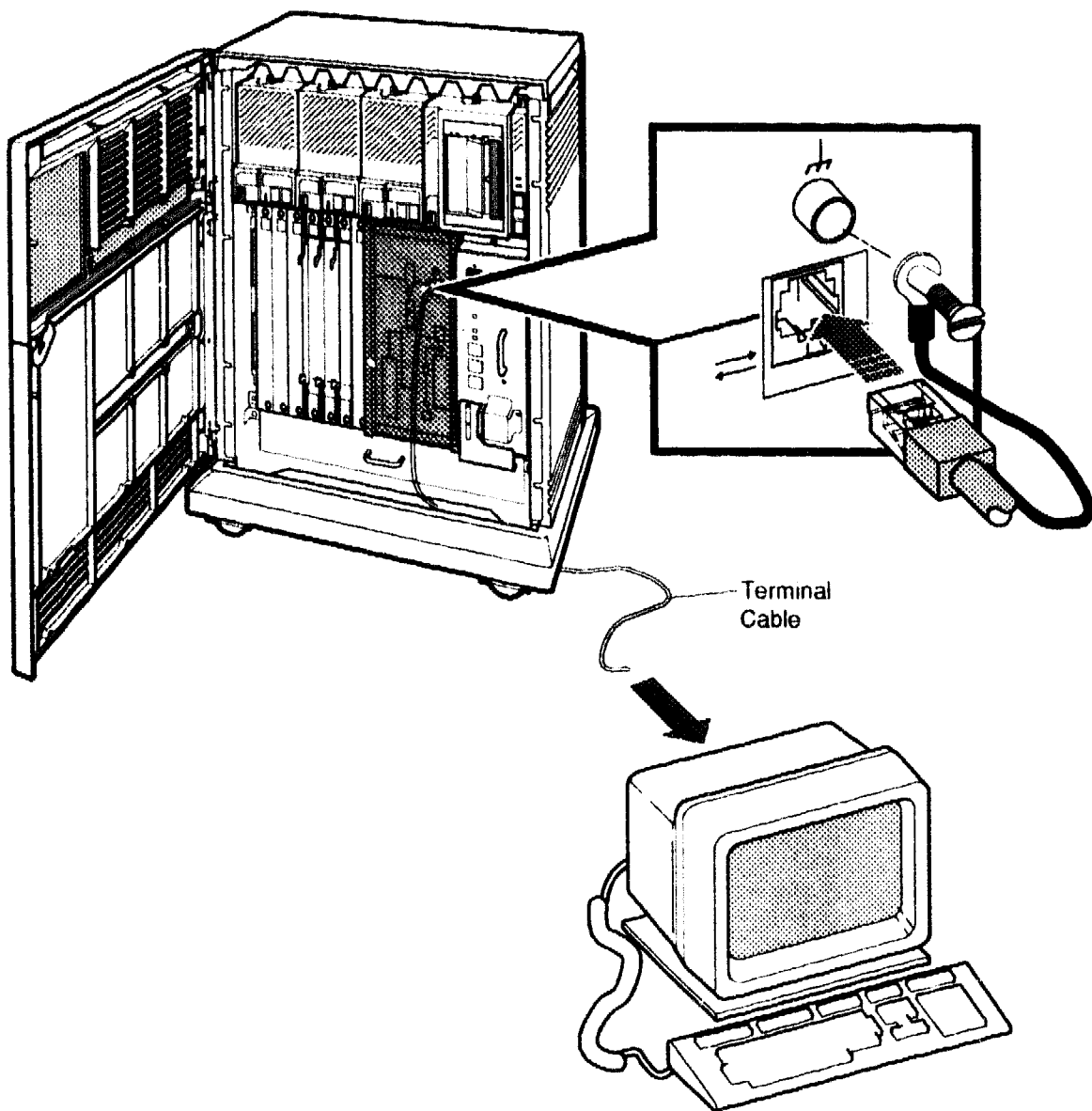

MLO-004014

## 2.4 Completing the Installation

Run the factory-loaded system software with only the system connected before completing the installation by connecting other devices.

Make cable connections directly to the module handles/covers. Begin with the module on the far right and continue toward the left.

Each module handle has a label at the top that contains the option number and module number. Table 2-4 lists the labels for modules requiring connections. Use the table to identify the modules as you connect additional devices to the system.

**Table 2-4: Module Identification Labels**

| <b>Module Number</b> | <b>Option Number</b> | <b>Enclosure Used</b> | <b>Functional Description</b>             |
|----------------------|----------------------|-----------------------|---|
| -----                | H3602-AA             | BA430                 | KA660 CPU cover panel                     |
| -----                | H3602-AC             | BA430                 | KN220 CPU cover panel                     |
| -----                | H3604-AA             | BA440                 | KA670 CPU console module                  |
| M7626-AA             | KA660-AA             | BA430                 | VAX 4000 Model 200 CPU module             |
| M7626-BA             | KA660-BA             | BA430                 | VAXserver 4000 Model 200 CPU module       |
| M5976-SA             | KZQSA-SA             | All                   | RDAT/SCSI Adapter                         |
| L4000-AA             | KA670-AA             | BA440                 | VAX 4000 Model 300 Timeshare CPU          |
| L4000-BA             | KA670-BA             | BA440                 | VAXserver 4000 Model 300 CPU              |
| L4001-BA             | MS670-BA             | BA440                 | VAX 4000 Model 300 memory, 32 MB          |
| L4001-CA             | MS670-CA             | BA440                 | VAX 4000 Model 300 memory, 64 MB          |
| L4002-BA             | KA680-AA             | BA440                 | VAX 4000 Model 500 CPU Module             |
| L4002-AA             | KA690-AA             | BA440                 | VAX 4000 Model 600 CPU Module             |
| L4004-BA             | MS690-BA             | BA440                 | VAX 4000 Model 500 and 600 memory, 32 MB  |
| L4004-CA             | MS690-CA             | BA440                 | VAX 4000 Model 500 and 600 memory, 64 MB  |
| L4004-DA             | MS690-DA             | BA440                 | VAX 4000 Model 500 and 600 memory, 128 MB |

**Table 2-4 (Cont.): Module Identification Labels**

| <b>Module Number</b>  | <b>Option Number</b> | <b>Enclosure Used</b> | <b>Functional Description</b>                                     |
|-----------------------|----------------------|-----------------------|---|
| M8578-00              | MRV11-D              | All                   | Programmable read-only memory                                     |
| M3127-PA              | DESQA-SA             | All                   | Ethernet adapter  |
| M3118-YA              | CXA16-AA             | All                   | 16-line asynchronous serial interface (RS-423-A no modem support) |
| M3118-YB              | CXB16-AA             | All                   | 16-line asynchronous serial interface (RS-422-A noise immune)     |
| M3119-YA              | CXY08-AA             | All                   | 8-line asynchronous serial interface (full modem support)         |
| M3108-PA              | DSV11-SA             | All                   | 2-line synchronous serial interface (full modem support)          |
| M3121-00              | DFA01-AA             | All                   | 2-line asynchronous serial interface with integral modem          |
| M7164-00,<br>M7165-00 | KDA50-SE             | All                   | SDI Mass Storage Adapter  |
| M7559-00              | TQK70-SA             | All                   | TK70 tape drive controller  |
| M7206-PA              | TSV05-SA             | All                   | TS05 tape drive controller (old)                                  |
| M7530-PA              | TSV05-SA             | All                   | TS05 tape drive controller (new)                                  |
| M7740-PA              | KLES1-SA             | All                   | RV20 write-once optical disk (or TU81E tape controller)           |
| M7546-00              | TQK50-SA             | All                   | TK50 tape drive controller  |
| M7552-PA              | KRQ50-SA             | All                   | RRD40/RRD50 CD-ROM controller                                     |
| M7500-PA              | KMV1A-SA             | All                   | RS232-C interface   |
| M7622-AA              | MS650-BA             | BA430                 | VAX 4000 Model 200 16 MB memory module                            |
| M7622-BA              | MS650-BB             | BA430                 | VAX 4000 Model 200 8 MB memory module                             |
| M7637-AA              | KN220-AA             | BA430                 | DECsystem 5500 CPU module   |
| M7638-AA              | KN220-AA             | BA430                 | DECsystem 5500 I/O module   |
| M7639-AA              | MS220-AA             | BA430                 | DECsystem 5500 32 MB memory module                                |
| M7639-BA              | MS220-BA             | BA430                 | DECsystem 5500 64 MB memory module                                |

**Table 2-4 (Cont.): Module Identification Labels**

| <b>Module Number</b> | <b>Option Number</b> | <b>Enclosure Used</b> | <b>Functional Description</b>     |
|----------------------|----------------------|-----------------------|-----------------------------------|
| M7658-PA             | DRQ3B-SA             | All                   | Real-time parallel interface      |
| M7651-PA             | DRV1W-SA             | All                   | Real-time parallel interface      |
| M7769-00             | KFQSA-SA             | All                   | DSSI mass storage adapter         |
| M8020-PA             | DPV11-SA             | All                   | Synchronous serial line interface |
| M8086-YA             | LPV11-SA             | All                   | Dual parallel printer interface   |
| M9715-AA             | ---                  | BA430                 | DSSI interface/terminator card    |

The following table lists the option cables.

**Table 2-5: Option Cables**

| <b>Module Number</b> | <b>Option Number</b> | <b>Cable Type</b>  |
|----------------------|----------------------|--|
| M3127-PA             | DESQA-SA             | Ethernet cable   |
| M3118-YA             | CXA16-AA             | BC16D, H3104 cable concentrator (RS-423-A, no modem support) |
| M3118-YB             | CXB16-AA             | BC16D, H3104 cable concentrator (RS-422-A, noise immune)     |
| M3119-YA             | CXY08-AA             | BC19N-12 (RS232 full modem support)                          |
| M3121-00             | DFA01-AA             | Telephone line   |
| M8020-YA             | DPV11-SA             | BC261-01   |
| M8086-YA             | LPV11-SA             | BC271-30   |
| M7164-00             | KDA50-SE             | BC26V  |
| M7165-00             | ---                  | ---  |
| M7500-PA             | KMV1A-SA             | RS232-C Interface  |

## 2.4.1 Setting Controls on the System

The controls you must set to complete the installation vary, depending on the CPU and type of disks in the enclosure. Generally, you must set the baud rate of the console serial line to the same baud rate as the console terminal, and be sure the fixed disk drives are ready and not write protected.

Refer to the system's *Operation* manual for detailed instructions on setting these controls for the particular system you are installing.

## 2.4.2 Connecting the Power Cable

Feed the power cable under the system from the rear and attach it to the connector at the base of the power supply (Figure 2-5). Plug the other end of the power cable into the wall outlet after all cabling has been installed. Option cables are listed in Table 2-5.

**Figure 2-5: Connecting the Power Cable**

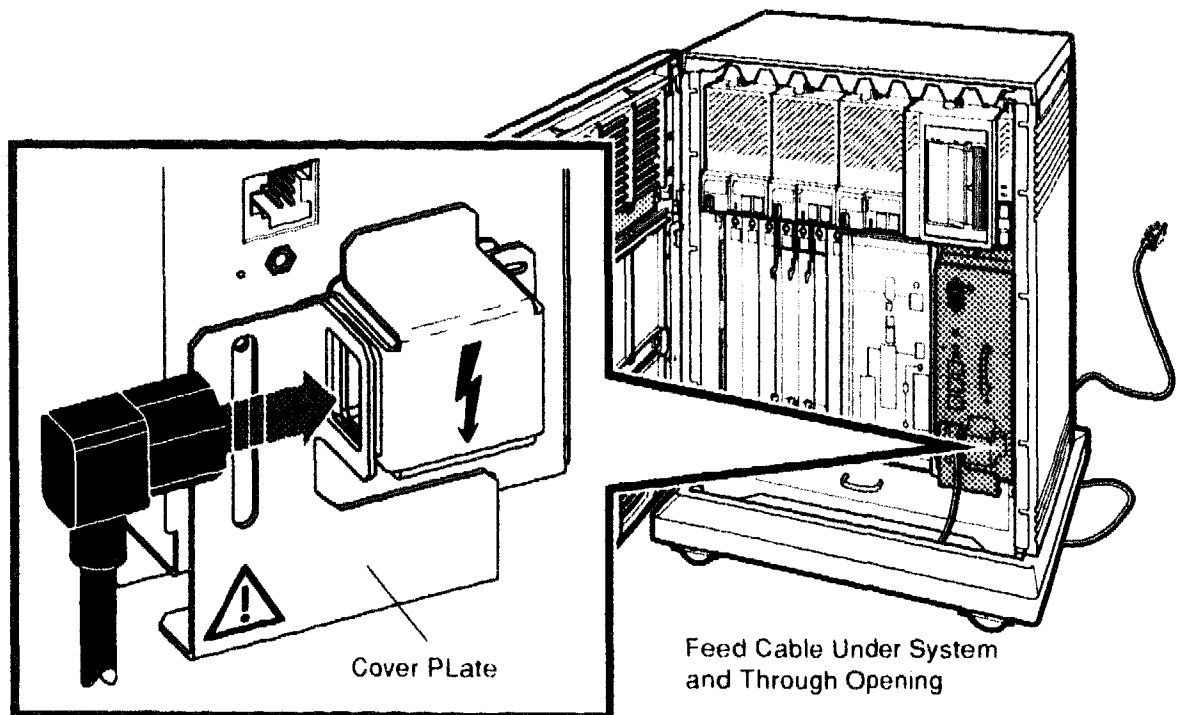

MLO 004029

## Chapter 3

# BA430/BA440 FRU Removal and Replacement

---

This chapter describes how to remove and replace the field-replaceable units (FRUs) in the BA430/BA440 enclosure.

The following sections describe the removal procedure for each FRU. Unless otherwise specified, you can install a FRU by reversing the steps in the removal procedure.

System-specific FRU procedures vary slightly. As a result, some illustrations of procedures show an *example* of a FRU removal. The variations are noted in the text and in the title of the illustration.

**NOTE:** *The illustrations in this chapter show the BA440 enclosure. Duplicating the same basic illustrations for the BA430 enclosure is unnecessary. The removal procedures are the same for both enclosures.*

### **CAUTION:**

- *Only qualified service personnel should remove or install FRUs.*
- *Turn off the system before you remove or install FRUs.*
- *Static electricity can damage integrated circuits. Always use a grounded wrist strap 29-26246-00 and a grounded work surface when working with the internal parts of a computer system.*

## 3.1 Field Replaceable Units (FRUs)

Table 3-1 lists the BA430/BA440 enclosure FRUs and their part numbers.

**Table 3-1: BA430/BA440 FRUs**

| <b>FRU</b>                              | <b>Part Number</b> | <b>Enclosure</b>          |
|---|--------------------|---------------------------|
| Assembly, bulkhead H3602-AC             | 70-25775-03        | BA430, DECsystem 5500     |
| Assembly, bulkhead H3602-AA             | 70-25775-01        | BA430, VAX 4000 Model 200 |
| Assembly, console H3604                 | 70-27400-01        | BA440                     |
| Module, console H3604                   | 70-27402-01        | BA440                     |
| Assembly, system control                | 70-27044-01        | BA430/BA440               |
| Backplane, BA430                        | 54-20181-01        | BA430                     |
| Backplane, BA440                        | 54-19354-01        | BA440                     |
| Battery pack (H3604)                    | 12-19245-01        | BA440                     |
| Battery pack (H3602)                    | 12-19245-01        | BA430                     |
| Board, Vterm dual regulator             | 54-20404-01        | BA440                     |
| Cable, H3604 data                       | 17-02353-01        | BA440                     |
| Cable, DSSI bulkhead, 50-cond. internal | 17-02502-01        | BA430/BA440               |
| Cable, DSSI external, 50-cond. external | 17-02152-03        | BA430/BA440               |
| Cable, SCSI (external, 2.5 ft.)         | 17-02659-03        | BA430/BA440               |
| Cable, SCSI (external, 6.0 ft.)         | 17-02659-02        | BA430/BA440               |
| Cable, SCSI 50-cond. bulkhead           | 17-02542-01        | BA430/BA440               |
| Cable, TQK50/TQK70                      | 17-01363-01        | BA430/BA440               |
| Cable, system control (SCP)             | 17-02493-01        | BA430/BA440               |
| Cable, power control (BA400 to BA400)   | 17-02638-01        | BA430/BA440               |
| Cable, power control (BA400 to BA200)   | 17-02637-01        | BA430/BA440               |
| EF51R-AA/AF disk drive                  | EF51-RA            | BA430/BA440               |
| EF52R-AA/AF disk drive                  | EF52-RA            | BA430/BA440               |
| EF53-AA/AF disk drive                   | EF53-A             | BA430/BA440               |
| EF-series battery pack                  | 12-37620-01        | BA430/BA440               |

**Table 3-1 (Cont.): BA430/BA440 FRUs**

| <b>FRU</b>   | <b>Part Number</b> | <b>Enclosure</b> |
|--|--------------------|------------------|
| EF/RF-series 5.25-inch ISE front panel               | 70-27049-01        | BA430/BA440      |
| EF/RF-series 5.25-inch ISE interface card            | 54-19787-01        | BA430/BA440      |
| EF/RF-series 5.25-inch ISE remote front panel module | 54-19791-01        | BA430/BA440      |
| EF/RF-series 5.25-inch ISE remote front panel cable  | 17-02706-01        | BA430/BA440      |
| Fans, DC   | 12-31500-01        | BA430/BA440      |
| Fuse, 0.5 A pico, 125 V                              | 12-09159-00        | BA440            |
| Fuse, 2.0 A pico, 125 V                              | 12-10929-06        | BA440            |
| Fuse, 1.5 A, 125 V                                   | 12-10929-08        | BA440            |
| Fuse, .062 A, 125 V                                  | 90-09122-00        | BA440            |
| Ground wire  | 12-13756-A8        | BA430/BA440      |
| Harness, fan tray                                    | 17-02507-01        | BA430/BA440      |
| Key  | 12-17119-01        | BA430/BA440      |
| Module, DSSI terminator/interface                    | M9715-AA           | BA430            |
| Module, power harness                                | 54-19789-01        | BA440            |
| Panel, dual blank                                    | 74-33507-01        | BA430/BA440      |
| Panel, drive filler                                  | 70-27414-01        | BA430/BA440      |
| Plug, address ID set (SCSI)                          | 12-28766-28        | BA430/BA440      |
| Plug, address ID set (DSSI)                          | 12-28766-19        | BA430/BA440      |
| Power supply, 120/240 V                              | H7874-00           | BA430/BA440      |
| RF31E-AA/AF disk drive                               | RF31-EA            | BA430/BA440      |
| RF31 head-disk assembly                              | 70-24697-01        | BA430/BA440      |
| RF31 electronic control module                       | 54-18329-01        | BA430/BA440      |
| RF31F-AA/AF disk drive                               | RF31F-EA           |                  |
| RF31F head disk assembly                             | 70-24697-01        | BA430/BA440      |
| RF31F electronic control module                      | 54-18329-02        | BA430/BA440      |

**Table 3-1 (Cont.): BA430/BA440 FRUs**

| <b>FRU</b>                                       | <b>Part Number</b> | <b>Enclosure</b>         |
|--|--------------------|--------------------------|
| RF31T-AA/AF disk drive                           | RF31T-EA           | BA430/BA440 <sup>1</sup> |
| RF35E-AA/AF disk drive                           | RF35-EA            | BA430/BA440 <sup>1</sup> |
| RF71E-AA/AF disk drive                           | RF71-EA            | BA430/BA440              |
| RF71 head-disk assembly                          | 70-23557-01        | BA430/BA440              |
| RF71 electronic control module                   | 54-18316-02        | BA430/BA440              |
| RF72E-AA/AF disk drive ISE                       | RF72-EA            | BA430/BA440              |
| RF72 head-disk assembly                          | 70-25972-01        | BA430/BA440              |
| RF72 electronic control module                   | 54-10091-01        | BA430/BA440              |
| RF73E-AA/AF disk drive                           | RF73-EA            | BA430/BA440              |
| RF73 head-disk assembly                          | 70-28814-01        | BA430/BA440              |
| RF73 electronic control module                   | 54-19119-01        | BA430/BA440              |
| RF-series 3.5-inch ISE front panel               | 70-29478-01        | BA430/BA440              |
| RF-series 3.5-inch ISE remote front panel cable  | 17-03428-01        | BA430/BA440              |
| RF-series 3.5-inch ISE interface card            | 54-19787-03        | BA430/BA440              |
| RF-series 3.5-inch ISE remote front panel module | 54-21530-01        | BA430/BA440              |
| RZ56E-AA/AF disk drive                           | RZ56-EA            | BA430                    |
| RZ56 electronic control module                   | 29-27889-01        | BA430                    |
| RZ56 head-disk assembly                          | 29-27890-01        | BA430                    |
| RZ57E-AA/AF disk drive                           | RZ57-EA            | BA430                    |
| RZ57 electronic control module                   | 29-28159-01        | BA430                    |
| RZ57 head-disk assembly                          | 29-28158-01        | BA430                    |
| RZ58E-AA/AF disk drive                           | RZ58-EA            | BA430 <sup>1</sup>       |
| RZ-series ISE interface card                     | 54-20136-01        | BA430/BA440              |
| RZ-series ISE remote front panel module          | 54-20400-01        | BA430                    |
| RZ-series ISE remote front panel cable           | 17-02887-01        | BA430                    |

<sup>1</sup>Entire unit is FRU. Head disk assembly (HDA) and electronic control module are not FRU level replacements

**Table 3-1 (Cont.): BA430/BA440 FRUs**

| <b>FRU</b>                          | <b>Part Number</b> | <b>Enclosure</b> |
|-------------------------------------|--------------------|------------------|
| RZ-series ISE front panel           | 70-27049-03        | BA430            |
| Terminator, SCSI                    | 12-30552-01        | BA430            |
| Terminator, DSSI                    | 12-29258-01        | BA440            |
| TF85E-JA/JF tape drive              | TF85-BA            | BA430/BA440      |
| TF85 interface card                 | 54-19787-02        | BA430/BA440      |
| TF85 remote front panel module      | 54-20336-01        | BA430/BA440      |
| TF85 ISE front panel                | 70-27050-01        | BA430/BA440      |
| TK50E-AA/AF tape drive              | TK50-EA            | BA430/BA440      |
| TK-series front panel               | 70-27050-02        | BA430/BA440      |
| TK-series interface card            | 54-20136-02        |                  |
| TQK50 controller                    | M7546-00           | BA430/BA440      |
| TK70-AA/AF tape drive               | TK70-EA            | BA430/BA440      |
| TQK70 controller                    | M7559-00           | BA430/BA440      |
| TLZ04-JA/JF tape drive              | TLZ04-AA           | BA430/BA440      |
| TLZ04 tape drive front panel module | 54-20438-01        | BA430/BA440      |
| TLZ04 tape drive interface card     | 54-20136-03        | BA430/BA440      |
| TLZ04 tape drive ID cable           | 17-01936-02        | BA430/BA440      |
| TLZ04 ISE front panel               | 70-28081-01        | BA430/BA440      |

Several different modules, disk ISEs, and tape ISEs may be present, depending on which CPU and mass storage devices are installed. Refer to the applicable CPU maintenance manual for a complete options list.

## 3.2 Removing Modules

**NOTE:** *The illustrations in this section show the BA440 enclosure. Duplicating the same basic illustrations for the BA430 enclosure is unnecessary. The removal procedures are the same for both enclosures.*

Modules designed for BA400-series enclosures have handles that provide both external I/O connections and an electrical and environmental seal for the card cage. Standard Q22-bus modules used in other enclosures, such as the TQK70, use a blank cover instead of a handle. There is a different removal procedure for the three types of modules.

- Modules with ratchet ejector handles
- Modules with attached handles
- Modules with covers

For more information about modules and handles see Section 1.3, Module Handles and Covers in Chapter 1.

### 3.2.1 Removing Modules with Ratchet Ejector Handles

**CAUTION:** *Static electricity can damage integrated circuits. Use the wrist strap and antistatic mat found in the static-protective service kit (29-26246-00) when you work with the internal parts of a computer system.*

Ratchet ejector handles (Figure 3-1) are used on the BA440 CPU and memory modules to ensure a snug fit against the system's backplane. This design ensures constant tension against the backplane for optimum connector pin contact.

The following procedure shows the logical steps used to remove a module with ratchet handles.

1. Unlock and open both access doors together to reach the Power switch on the power supply.
2. Set the Power switch to off (0).
3. Put on the grounded wrist strap and attach the alligator clip to the system's chassis.
4. Note the orientation of external cables connected to the H3604 console module. Label and disconnect the cables (if applicable).
5. Release the quarter-turn captive screws that hold the H3604 console module to the card cage (Figure 3-2).
6. Swing open the H3604 console module.
7. Note the orientation of the internal cables connected to the module behind the module cover. Carefully disconnect the internal cables (if applicable).
8. Move the ratchet handles to the side to release them from the sloping teeth (Figure 3-1), then gently pull the ratchet handles toward you and slide the module out of the card cage (if applicable).

**Figure 3–1: Ratchet Ejector Handles**

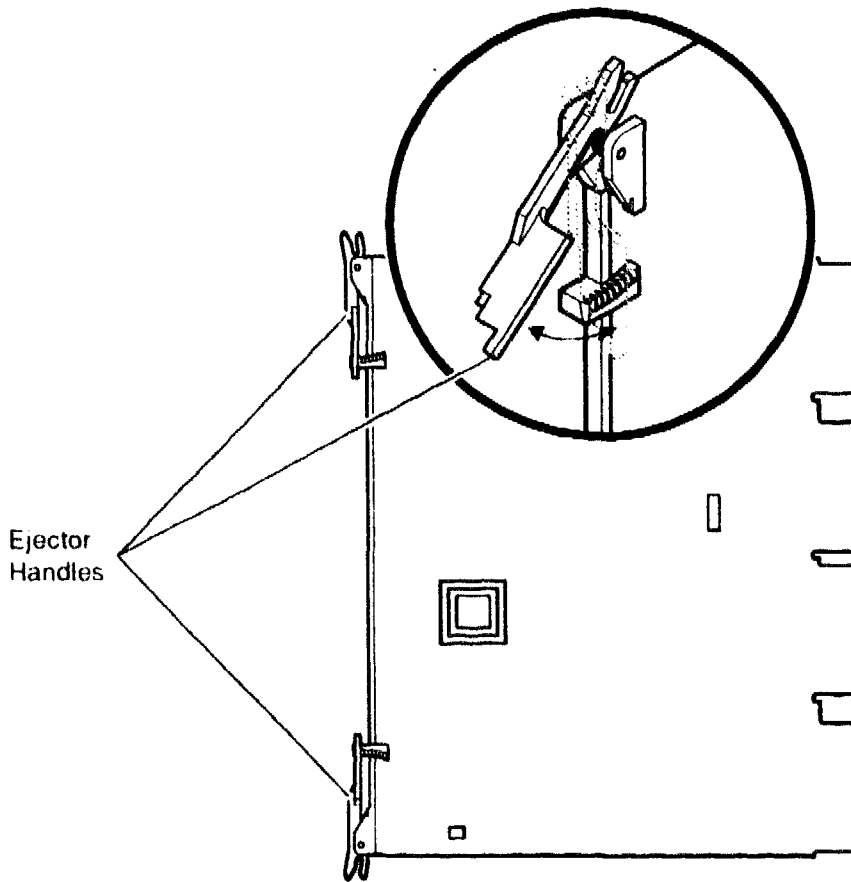

MLO 004227

### **3.2.2 Removing Modules with Attached Handles**

**CAUTION:** *Use the static-protective service kit (29-26246-00) when working with modules.*

1. Unlock and open both access doors together to reach the Power switch on the power supply.
2. Set the Power switch to off (0).
3. Put on the grounded wrist strap and attach the alligator clip to the system's chassis.
4. Label and disconnect the cables. Note the orientation of external cables that may be connected to the module handle.

5. Release the quarter-turn captive screws that hold the handle to the card cage (Figure 3-2).
6. Gently pull the release handles at the top and bottom of the module toward you and slide the module out of the card cage. (Figure 3-3).

**Figure 3-2: Releasing Quarter-Turn Captive Screws**

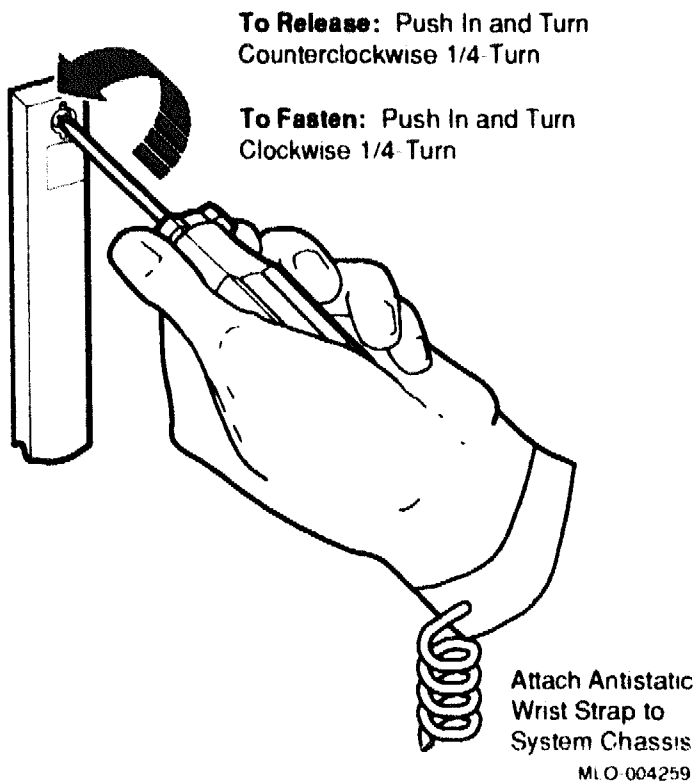

**Figure 3-3: Removing a Module**

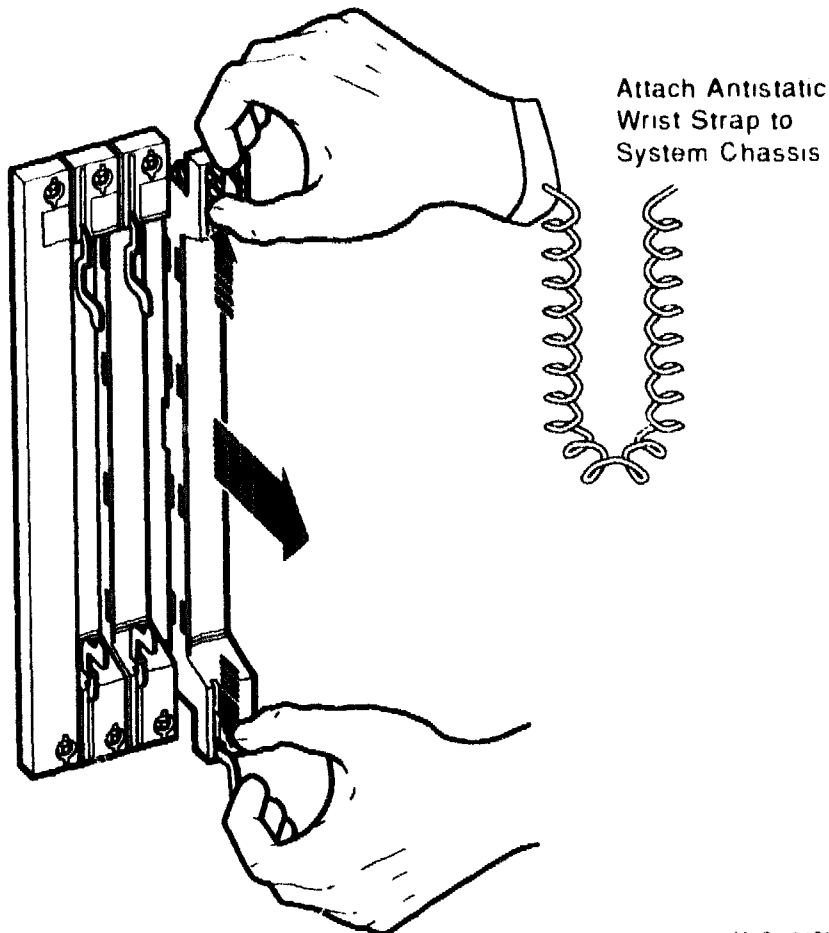

MLO 004209

### **3.2.3 Removing Modules with Covers**

**CAUTION:** *Use the static-protective service kit (29-26246-00) when working with modules.*

1. Unlock and open both access doors together to reach the Power switch on the power supply.
2. Set the Power switch to off (0).
3. Put on the grounded wrist strap and attach the alligator clip to the metal part of the system's chassis.
4. Release the quarter-turn captive screws that hold the cover to the card cage (Figure 3-2). Set the cover aside.

5. Note the orientation of any internal cables connected to the module behind the module cover. Some connectors are not keyed. Carefully disconnect the internal cables.
6. Pull the module lever handle out from the top and bottom and slide the module out of the card cage.

### 3.2.4 Special Modules

The following three modules are system-specific and dedicated to a specific enclosure and not considered options.

#### 3.2.4.1 M9715-AA Interface Module (BA430 Enclosure Only)

The M9715-AA interface module is located to the left of the H7874 power supply. This module is positioned in slot 0, a dedicated slot, which is the first backplane slot.

To remove the M9715 module, first remove the bulkhead assembly from slot 0. The M9715 module is installed in slot 0 behind the bulkhead assembly.

#### 3.2.4.2 M7638-AA I/O Module (BA430/DECsystem500)

The M7638-AA I/O module is located in slot 1 next to the M9715 module, behind the H3605 I/O bulkhead connector.

To remove the M7638 module, first remove all attached cables from the H3605 I/O connectors and then remove the H3605 bulkhead panel from slot 1.

#### 3.2.4.3 Vterm Board Removal (BA440 Enclosure Only)

To remove the Vterm board from the BA440 enclosure backplane, perform the following steps:

1. Open the upper access door.
2. Remove the third drive (if installed, counting from the left).
3. Remove the single screw holding the Vterm board to the backplane and remove the board.

**CAUTION:** *The screw holding this board is not a captive screw.*

To install a Vterm board, reverse the removal procedure.

### 3.3 Replacing EF-, RF-, and RZ-Series ISEs

This section describes how to replace EF-, RF-, or RZ-series ISEs. In addition, procedures are provided to replace the following individual FRUs that make up the mounting hardware for the ISE:

- ISE front panel module
- Interface card assembly
- Remote front panel cable

For information on troubleshooting strategy, error analysis, and diagnostics, as well as information on removal and replacement of the drive module and head-disk assembly (HDA), refer to the appropriate service manual for the device. Replacing the drive module on an ISE does not require removal of the ISE mounting hardware, except when there are dual drive ISEs.

**NOTE:** *There are two variants of the EF-series.*

- *EFxxR*
- *EFxx*

*The EFxxR contains a battery that you can replace, or if necessary you can replace the whole device. Since the EFxx contains no replaceable parts, you must replace a failed EFxx with a new device.*

#### 3.3.1 Removing an ISE from the Mass Storage Cavity

Use the following instructions to remove an EF-/RF-/RZ-series ISE. Refer to Figure 3-4.

**NOTE:** *The ISE figures throughout this chapter show the RF-series variety, but the procedures are identical for the EF- and RZ-series ISEs.*

**CAUTION:** *Static electricity can damage integrated circuits. Use the wrist strap and antistatic mat found in the static-protective service kit (29-26246-00) when you work with the internal parts of a computer system.*

*Handle ISEs with care. Dropping or bumping the ISE can damage the disk surface. Carry or hold the ISEs by their metal brackets to avoid damaging the drive module.*

**Figure 3-4: Remove the ISE**

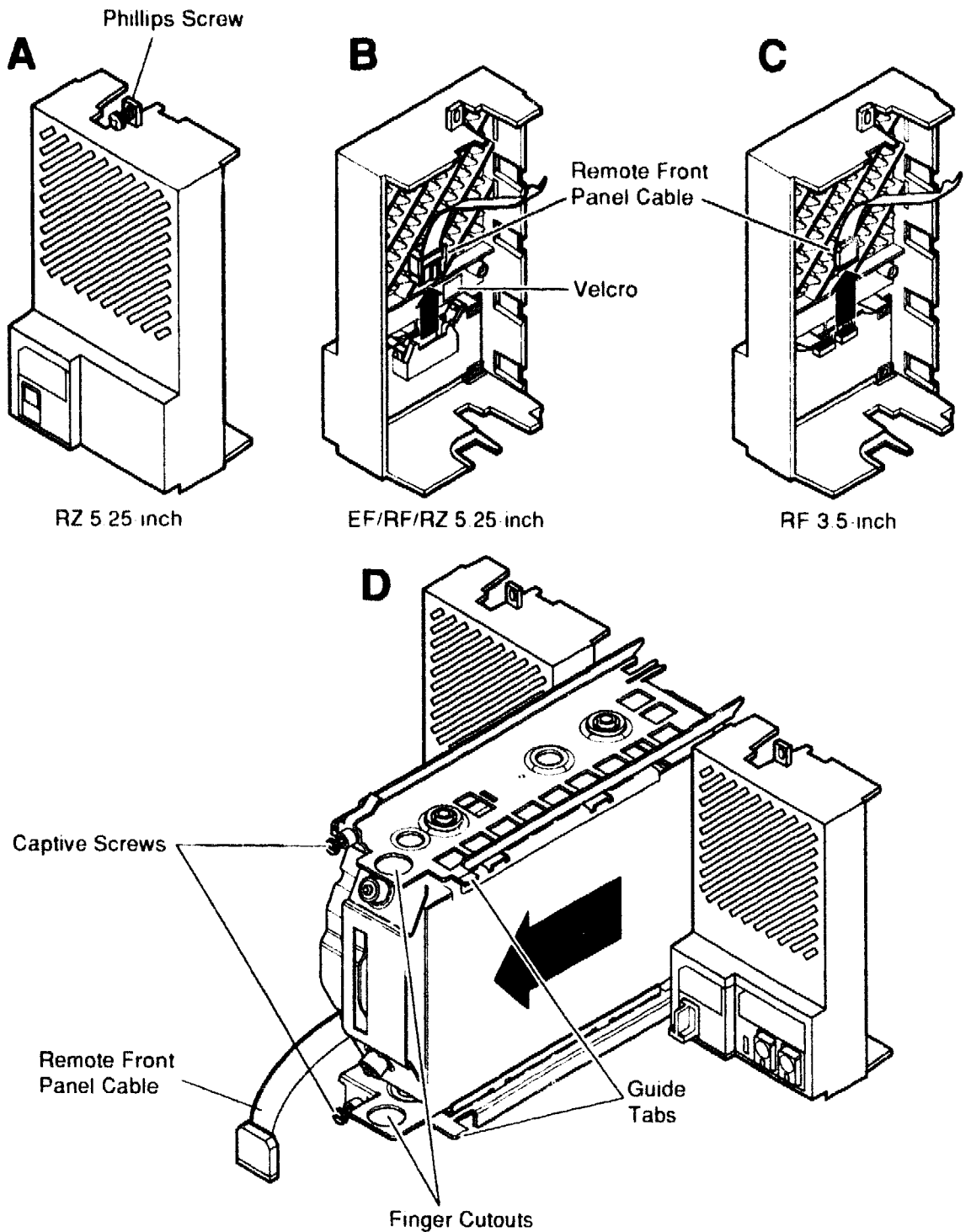

MLO-007247

1. Loosen the single captive Phillips screw that secures the ISE front panel (Figure 3-4A).
2. Separate the ISE front panel from the enclosure, being careful of the remote front panel cable, which is connected to the ISE front panel.

**NOTE:** *If the cause of the ISE failure is undetermined, inspect the connection of the remote front panel cable to the ISE front panel module. The cable may not be connected securely, or the cable or connector may be defective.*

*If the front panel module appears to be the problem, refer to Section 3.3.3 for instructions on replacing the ISE front panel module (54-19791-01 5.25-inch EF/RF-series; 54-21530-01 3.5-inch RF-series; 54-20400-01 RZ-series). To replace the remote front panel cable, continue removing the ISE and then refer to Section 3.3.5 for instructions on replacing the remote front panel cable (17-02706-01 5.25-inch EF/RF-series; 17-02887-01 5.25-inch RZ-series).*

*If the remote front panel cable 17-03428-01 on a 3.5-inch RF-Series ISE is defective refer to Section 3.3.2.*

3. Unplug the remote front panel cable from the module inside the ISE front panel (Figure 3-4B, C) and set the front panel aside.

**NOTE:** *To ensure that each bus node ID plug remains with the original storage device, repair or replace only one ISE at a time.*

4. Loosen the upper and lower captive screws that hold the ISE in place (Figure 3-4D).
5. Using the upper and lower finger cutouts on the ISE bracket, carefully pull the ISE out of its backplane connector and slide the drive out of the enclosure. Support the weight of the ISE at the underside of the lower bracket as the ISE clears the enclosure (Figure 3-4D).

**CAUTION:** *Do not touch the drive module. The drive module contains sensitive electronic circuitry.*

**NOTE:** *If the cause of the ISE failure is undetermined, inspect the condition of the interface card and its associated cables and cable connections. Refer to Section 3.3.4.1 for instructions on replacing the interface card assembly (54-19787-01 5.25-inch EF/RF-series; 54-20136-01 5.25-inch RZ-series). See Section 3.3.4.2 to replace the interface card assembly 54-19787-03 3.5-inch RF-Series.*

6. Reverse the procedure to reinstall the ISE.

### **3.3.2 Replacing the Remote Front Panel Cable on a 3.5-inch RF-series ISE**

This procedure assumes you have completed steps 1 and 2 in Section 3.3.1. Complete the following steps to replace the defective cable:

1. Unplug the remote front panel cable(s) from the connector(s) inside the ISE front panel module (Figure 3-4B, C).
2. Unplug the remote front panel cable(s) from the connector on the controller board.
3. Examine the remote front panel cable very carefully, and if you find that the cable(s) is (are) defective, replace it (them).
4. Reverse the procedure to install the new remote front cable.

### **3.3.3 Replacing the ISE Front Panel Module**

This procedure assumes you have completed steps 1 and 2 in Section 3.3.1. Use the following instructions to remove the ISE front panel module (54-19791-01 5.25-inch EF/RF-series; 54-20400-00 5.25-inch RZ-series; 54-21530-01 3.5-inch RF-series) and refer to Figure 3-5.

1. Unplug the remote front panel cable(s) from the connector(s) inside the ISE front panel module.  
For the 5.25-inch EF-, RF-, and RZ-series ISEs (Figure 3-4B)  
For the 3.5-inch RF-series ISEs (Figure 3-4C)
2. Remove the bus node ID plug(s) on the ISE front panel by pulling it (them) straight out. Note the positions of the plugs on a dual drive, so you can reinstall the plugs in the original positions.
3. Lift the two plastic tabs that hold the front panel module in place and remove the module.
4. Reverse the procedure to install a module.

**Figure 3-5: Removing an ISE Front Panel Module**

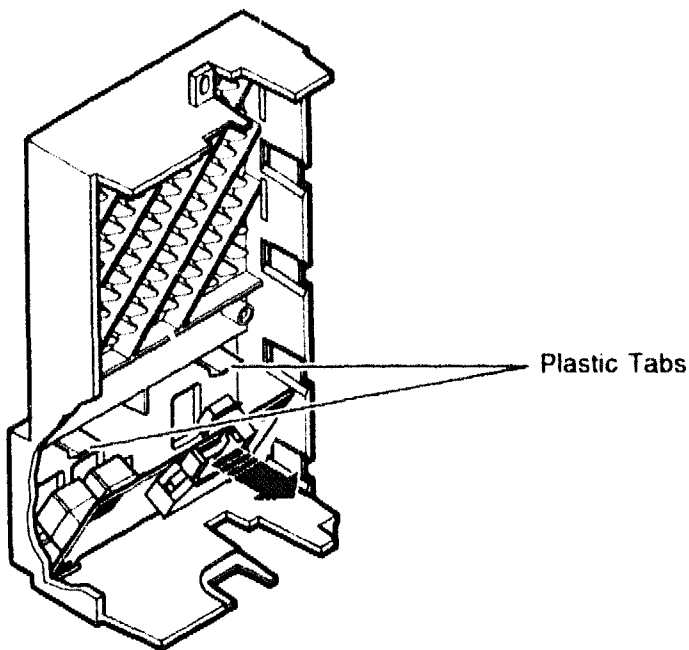

MLO 004249

### **3.3.4 Replacing the Interface Card**

There are two procedures for replacing the interface card:

- Replacing the interface card on a 5.25-inch EF-, RF-, or RZ-series ISE
- Replacing the interface card on a 3.5-inch RF-series ISE (See Section 3.3.4.2)

Complete the following steps to replace the interface card assembly on a 5.25-inch ISE.

#### **3.3.4.1 Replacing the Interface Card on the 5.25-inch EF-, RF- and RZ-Series ISEs**

The following sections contain instructions for removing the interface card assembly (54-19787-01 5.25-inch EF/RF-series; 54-20136-01 5.25-inch RZ-series).

### 3.3.4.1.1 Remove the Top Bracket

This procedure assumes you have removed the ISE as described in Section 3.3.1.

Remove the ISE's top bracket as follows:

1. Place the ISE on an antistatic mat.
2. Remove the two Phillips screws at the rubber shock bushings that secure the top bracket to the head-disk assembly (Figure 3-6).

**CAUTION:** *Early models of the RF-series ISEs use four screws of two different lengths to secure the top and bottom brackets. The two longer screws (by one-eighth inch) must only be used in the shock bushing toward the back of the drive. If this is not done, the drive may be damaged.*

**Figure 3-6: Removing Bracket Screws**

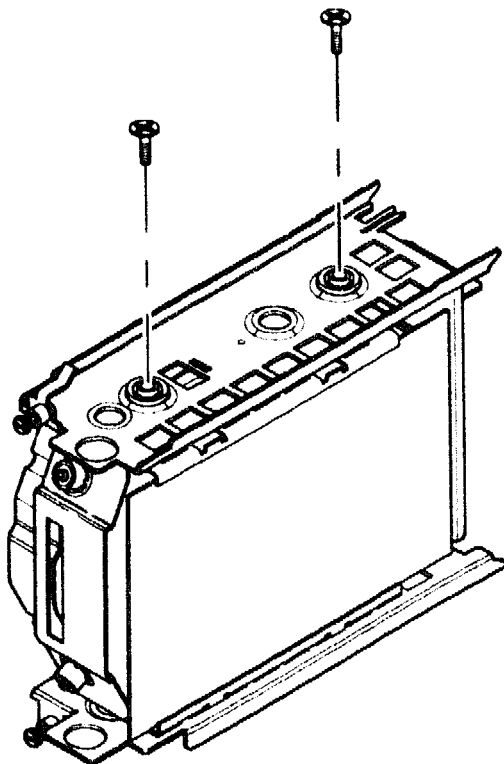

MLO 004213

3. Slide the interface card assembly up and lift off the top bracket (Figure 3-7). Place the bracket aside.

**Figure 3-7: Removing the ISE Top Bracket**

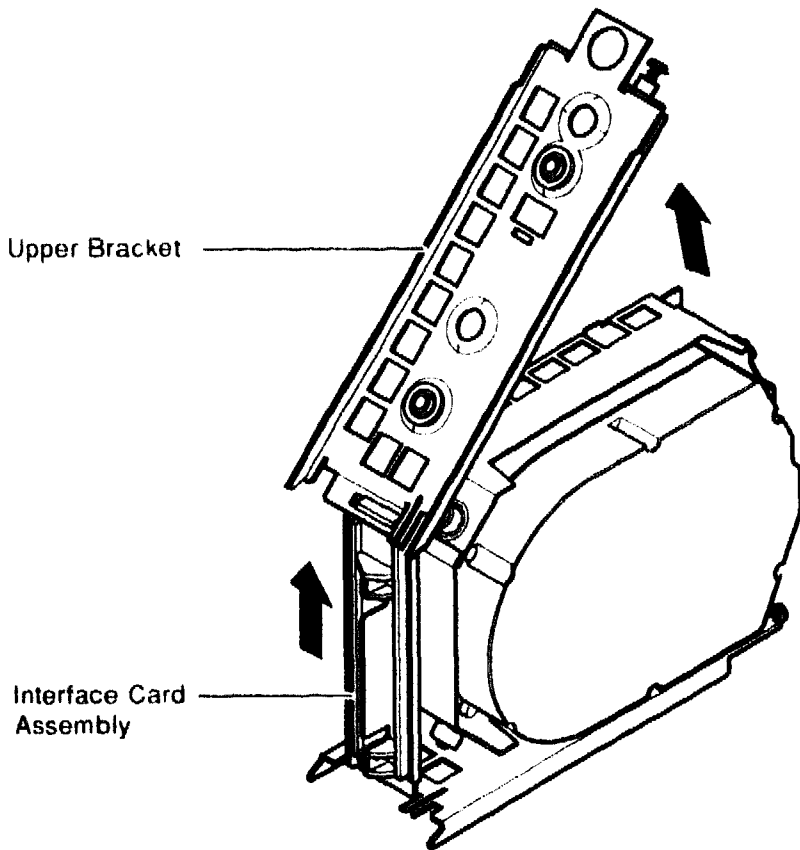

MLO-004214

#### **3.3.4.1.2 Install the New the Interface Card**

Remove the interface card assembly as follows:

1. Unplug the 5-pin (EF/RF-series) or 4-pin (RZ-series) power cable and the 50-pin signal cable from their connectors on the ISE controller module.

**NOTE:** *Observe cable routing to ensure that you route the cables properly when reassembling.*

2. Lift and remove the plastic interface card assembly being careful to guide the cables through the cutout in the metal bracket (Figure 3-8).

3. To remove the plastic assembly from the interface card, remove the two Phillips screws that hold it in place (Figure 3–8). Save the two Phillips screws.
4. Set the new interface card on the plastic assembly so that the power harness is on the side nearest the flange. Use the two Phillips screws to secure the interface card to the plastic assembly.

**NOTE:** *Tighten the screws only until they are securely fastened (3 inch-pounds).*

5. Reverse the procedure to install the interface card assembly.

**Figure 3–8: Replacing the Interface Card Assembly**

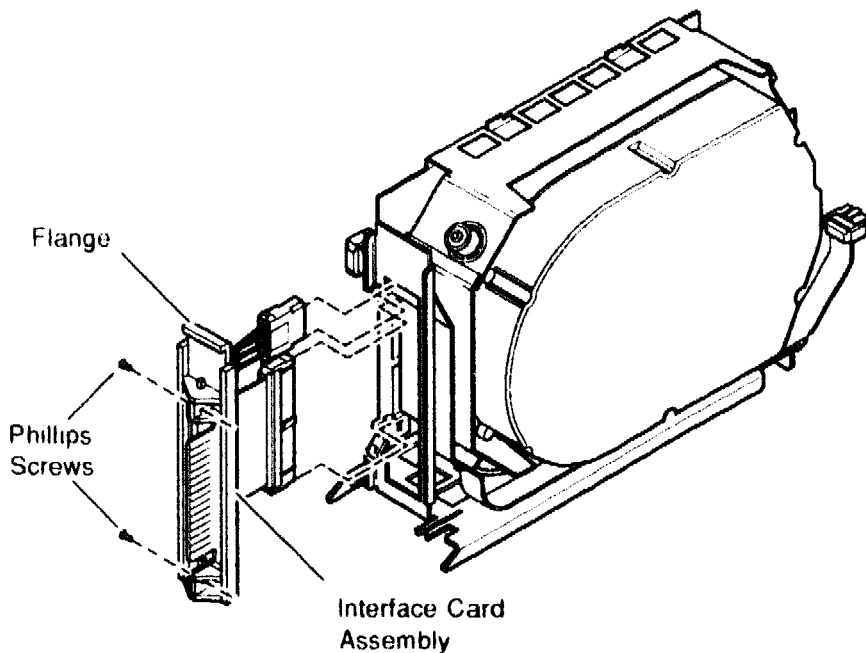

M.I.O.004257

### **3.3.4.2 Replace the Interface Card on 3.5-Inch RF-Series ISEs**

The following sections describe how to replace the interface card on the 3.5-inch RF-series ISEs.

#### **3.3.4.2.1 Remove the Top Outside Bracket**

Place the ISE on an antistatic mat.

This procedure assumes you have removed the ISE as described in Section 3.3.1.

Complete the following steps to remove the top outside bracket from the ISE:

1. Unplug the remote front panel cable(s) from the storage device(s). Set it (them) aside; it (they) will be reinstalled later in the procedure.
2. Remove the two Phillips screws at the rubber shock bushings on the top outside bracket and put them aside.
3. Push up the plastic flange of the interface card assembly, and lift the top outside bracket's rear slot over the plastic flange (Figure 3-9).

**Figure 3-9: Remove the Top Outside Bracket From the ISE**

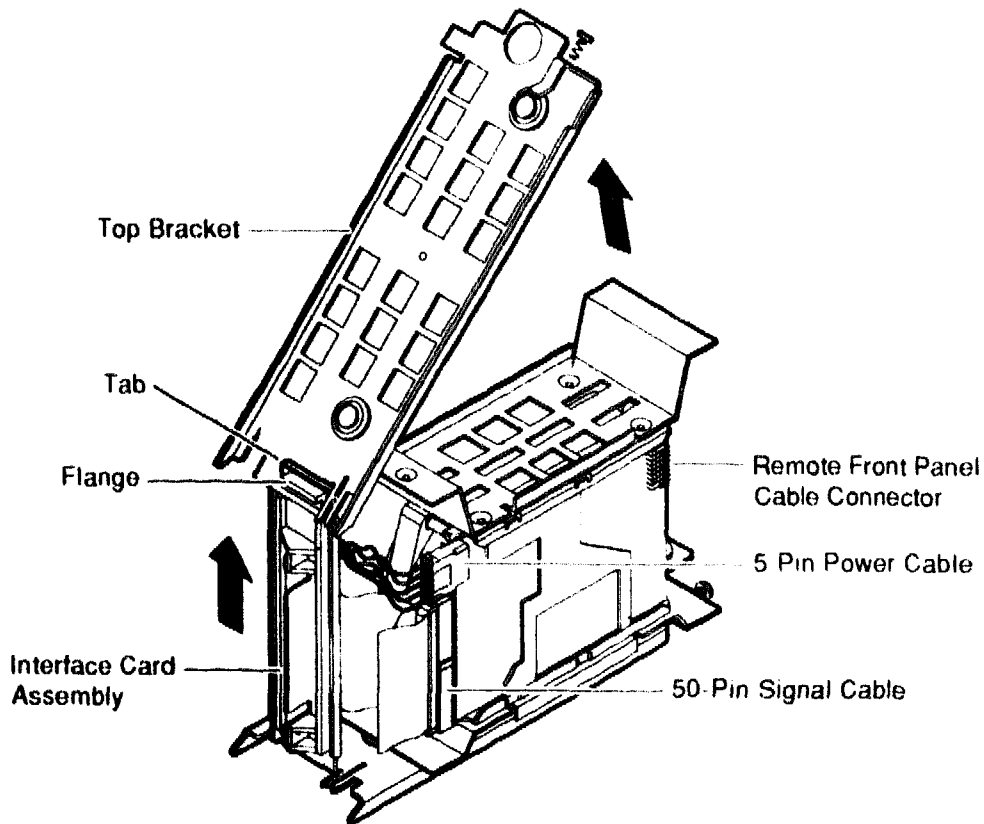

MLD-007241

### **3.3.4.2.2 Remove the Old Interface Card and Install the New Interface Card**

Complete the following steps to remove the interface card:

1. Unplug the 5-pin power cable(s) and the 50-pin signal cable(s) from their connectors on the ISE controller modules (Figure 3-9).

**NOTE:** *Observe the cable routing to ensure that you route the cables properly when reassembling.*

2. Remove the plastic interface card assembly, being careful to guide the cables through the cutout in the back of the bottom outside bracket (Figure 3-10).

**Figure 3-10: Replace the Interface Card**

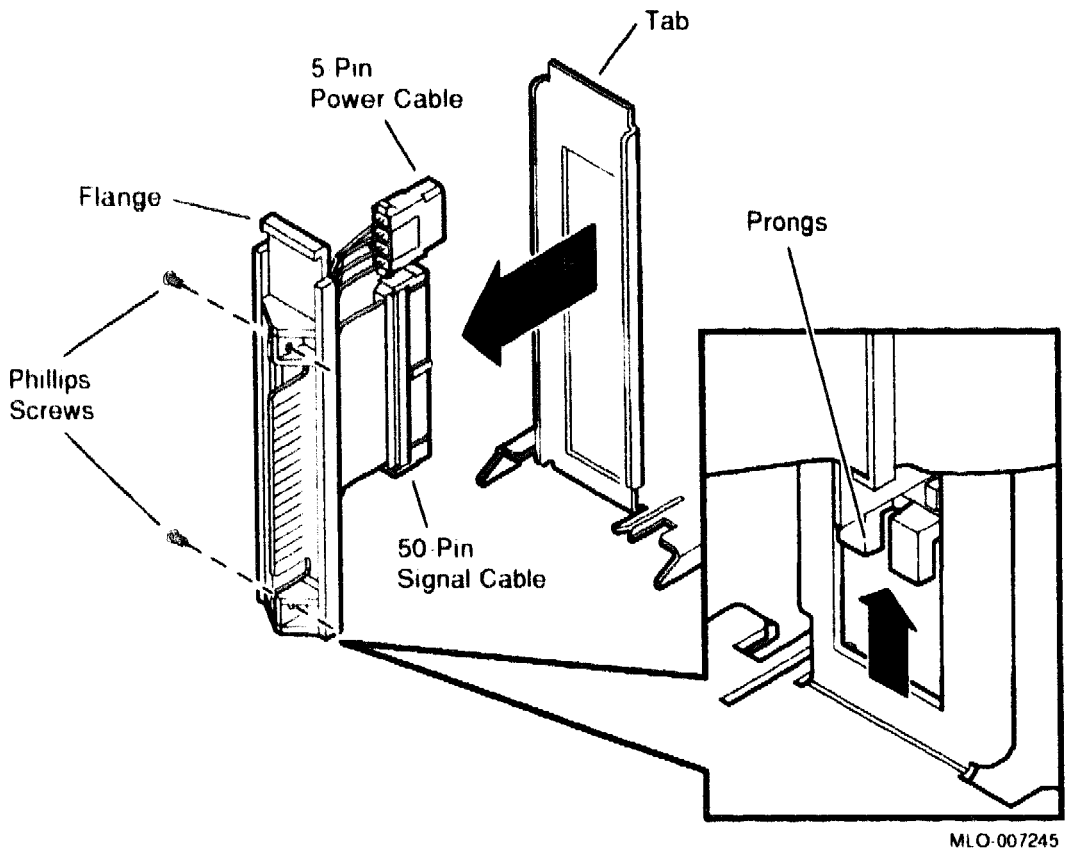

MLO-007245

3. To remove the interface card from the plastic assembly, remove the two Phillips screws that hold it in place. Do not discard the two Phillips screws.
4. Set the new interface card on the plastic assembly so that the power harness is on the side nearest the flange. Use the two Phillips screws to secure the interface card to the plastic assembly.

**NOTE:** Tighten the screws only until they are securely fastened (3 inch-pounds).

5. Reverse the procedure to install the interface card assembly.

### **3.3.5 Replacing the Remote Front Panel Cable on 5.25-inch ISEs**

To remove the remote front panel cable, you first remove the ISE as described in Section 3.3.1 and the ISE top bracket as described in Section 3.3.4.1.1. At this point the following procedures have to be completed:

1. Unplug the interface card assembly power cable (5 pin cable on the EF/RF-series, and 4 pin cable on the RZ-series) from the drive.
2. Unplug the interface card assembly 50 pin data cable from the drive.
3. Unplug the remote front panel cable from the drive.
4. Remove the ISE bottom bracket by removing the two Phillips screws at the rubber shock bushings that secure the bracket to the the head-disk assembly (Figure 3-11).

**NOTE:** *Take careful note of the orientation and routing of the front panel cable.*

5. To remove the remote front panel cable, pull the cable from the bottom bracket at the two points where the cable is secured by Velcro.
6. Reverse the procedure to install the remote front panel cable.

**Figure 3-11: Removing the Remote Front Panel Cable**

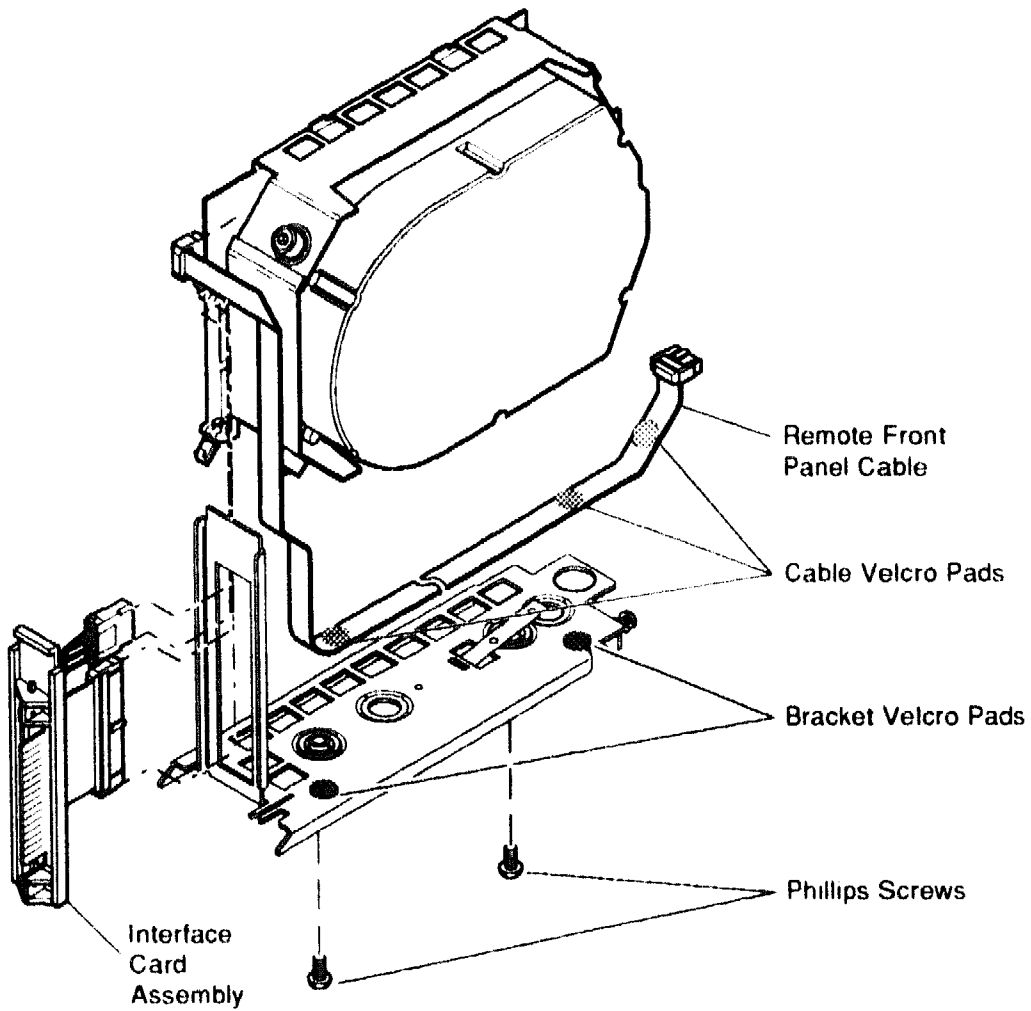

MLO 004258

### 3.3.6 Replacing a Storage Device on a 5.25-inch RF- or RZ-Series ISE

**CAUTION:** *Static electricity can damage integrated circuits. Use the antistatic wrist strap and antistatic pad found in the static-protective field service kit (29-26246-00) when you work with the internal parts of a computer system.*

This section describes how to replace a storage device on a 5.25-inch RF- or RZ-series ISE. This procedure assumes that you have removed the ISE as described in Section 3.3.1.

**NOTE:** *The only internal component of an EF-series ISE that can be replaced, is the battery pack (12-37620-01) (see Section 3.3.8). If any of the other internal components of an EF-series ISE fails, the complete ISE must be replaced.*

To remove the storage device complete the following procedures:

1. Place the ISE on an antistatic mat.
2. Unplug the interface card power cable (5 pin cable on RF-series and 4 pin cable on RZ-series) from the controller module on the drive.
3. Unplug the signal cable (50 pin) from the controller module on the drive.
4. Unplug the remote front panel cable from the controller module on the drive.
5. Remove the top bracket, by removing the two Phillips screws at the rubber shock bushings that secure the bracket to the head-disk assembly. Put the mounting screws aside, you will need them when you install the new drive
6. Slide the interface card assembly up and lift off the top bracket (Figure 3-12). Place the bracket aside.

**Figure 3-12: Removing the ISE Top Bracket**

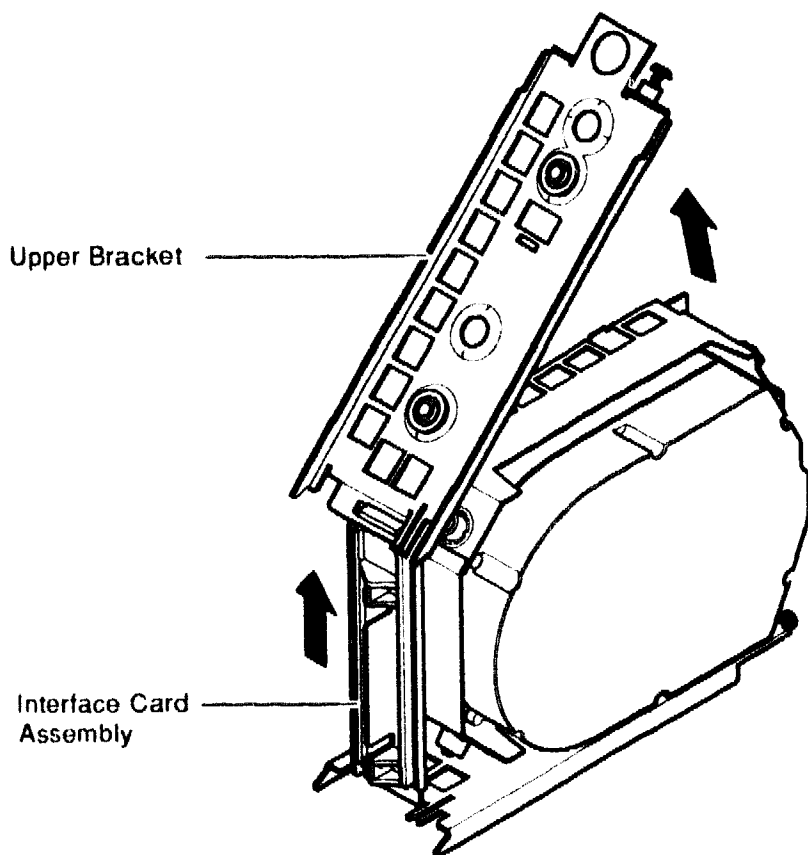

MLO-004214

7. Remove the bottom bracket by removing the two Phillips screws at the rubber shock bushings that secure the bracket to the the head-disk assembly (Figure 3-11). Put the bottom bracket (with the remote front panel cable attached) and the screws aside.
8. Remove and put the drive aside.
9. Reverse the procedure to install the new drive.

### **Installation Notes**

When you install the new drive be sure to complete the following:

1. Early models of the RF-series ISEs use four screws of two different lengths to secure the top and bottom brackets. The two longer screws (by one-eighth inch) must only be used in the shock bushing toward the back of the drive. *Failure to do this can result in damage to the drive.*

2. Align the new storage device in the same orientation as the original device, the controller module to the right.
3. When reinstalling the top bracket, lift the top bracket's rear slot over the flange of the plastic interface card assembly, and then over the tab at the back of the bottom outside bracket. Both the tab and the flange must be inside the rear slot of the top bracket.
4. Make sure that the grounding foil is in place under the front mounting screw on the bottom bracket.

### **3.3.7 Replacing a Storage Device on a 3.5-inch RF-Series ISE**

**CAUTION:** *Static electricity can damage integrated circuits. Use the antistatic wrist strap and antistatic pad found in the static-protective field service kit (29-26246-00) when you work with the internal parts of a computer system.*

The 3.5-inch RF-Series ISE may contain one storage devices or it may contain two storage devices.

The following section describes how to replace a storage device on a 3.5-inch RF-series ISE. This procedure assumes that you have removed the ISE as described in Section 3.3.1.

To remove a storage device complete the following procedures:

1. Place the ISE on an antistatic mat.
2. Remove the two mounting screws on the top outside bracket and put them aside.
3. Push up the plastic flange of the interface card assembly, and lift the top outside bracket's rear slot over the plastic flange. Put the bracket aside. (Figure 3-13)

**Figure 3-13: Remove the Top Outside Bracket From the ISE**

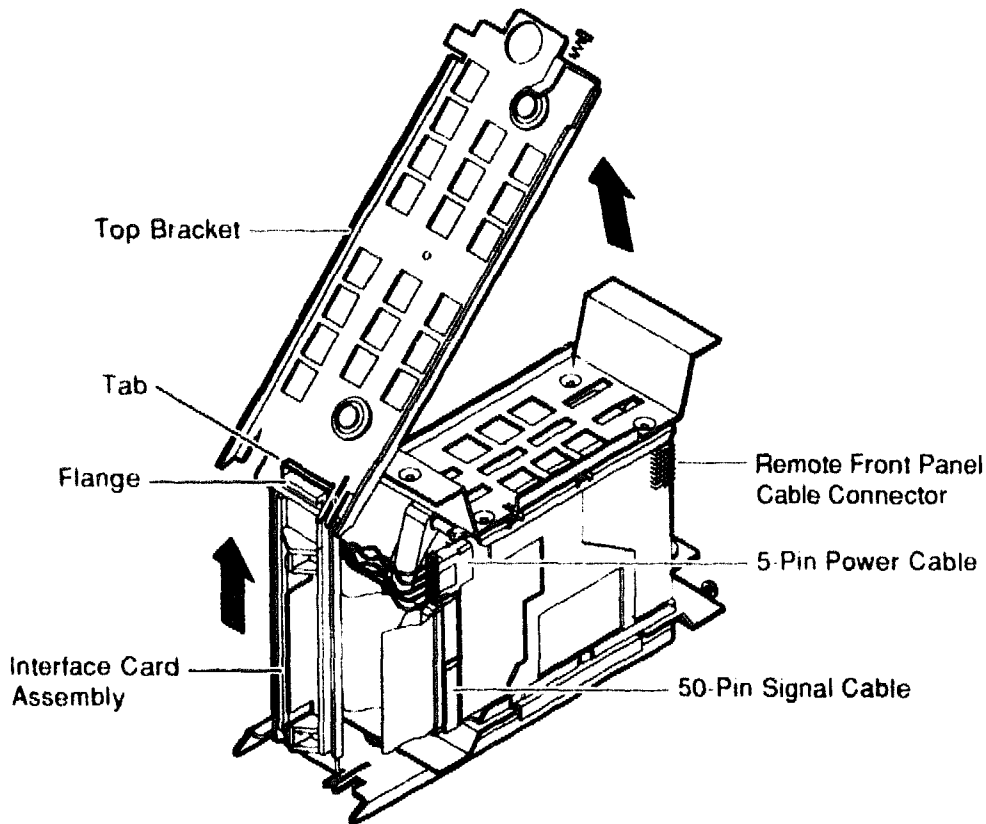

MLO-007241

4. Unplug the 5-pin power cable(s) and the 50-pin signal cable(s) from their connectors on the ISE controller module(s).
5. Unplug the remote front panel cable(s) from the controller module(s) on the storage device(s) and put it (them) aside.

When you remove a storage device from an ISE that contains a single storage device:

- a. Remove the top inside bracket, by removing the two Phillips screws that secure the bracket to the head-disk assembly. Place the bracket and the mounting screws aside, you will need them when you install the new drive.
- b. Gently turn the storage device upside down so that it rests on the head-disk assembly.

When you remove a storage device from an ISE that contains two storage devices:

- a. Remove the two Phillips screws that secure the top inside bracket to storage device. Set the screws aside for future use.
  - b. Gently turn the storage device upside down so that it rests on the top inside bracket.
6. After removing both mounting screws on the bottom outside bracket, set the bracket and the screws aside.
  7. After removing the Phillips screws that secure the storage device to the bottom inside bracket (Figure 3-14) you are ready to install the new storage device.

**Figure 3-14: Removing the Phillips Screws that Secure the Storage Device to the Bottom Inside Bracket**

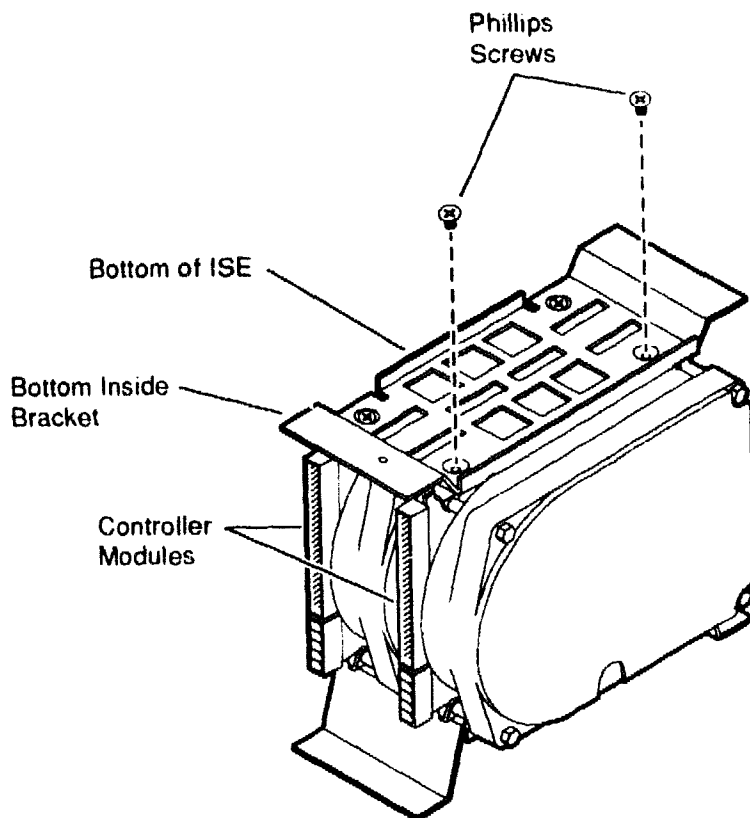

MLO-007246

8. Remove the screws that secure the bottom inside bracket to the storage device. Set them aside for future use.

9. Slide the storage device out and place it on an antistatic mat.

### **3.3.7.1 Installing the New Storage Device**

Complete the following procedures to install a new storage device:

1. Secure the bottom inside bracket to the storage device.
2. Secure the top inside bracket to the storage device.
3. Reinstall the bottom outside bracket and then the top outside bracket.
4. Reconnect the power (5 pin) and signal (50 pin) cables.
5. Reconnect the remote front panel cable(s) to controller module(s) on the storage device(s).

### **Installation Notes**

When you install the new drive be sure to complete the following:

1. Align the new storage device in the same orientation as the original device, the controller module to the left.
2. When reinstalling the top outside bracket, lift the bracket's rear slot over the flange of the plastic interface card assembly, and then over the tab at the back of the bottom outside bracket. Both the tab and the flange must be inside the rear slot of the top outside bracket.
3. Make sure that the grounding foil is in place under the front mounting screw on the bottom outside bracket.

## **3.3.8 Replacing the Battery Pack on an EF-Series ISE**

This procedure assumes you have removed the ISE as described in Section 3.3.1.

### **3.3.8.1 Removing the Mounting Hardware from an EF-Series ISE**

Remove the ISE's top bracket and bottom bracket as follows:

1. Place the ISE on an antistatic mat.
2. Remove the two Phillips screws at the rubber shock bushings that secure the top bracket to the side of the chassis (Figure 3-15). Put the screws aside.
3. Slide the interface card assembly up and lift off the top bracket (Figure 3-15). Place the bracket aside.
4. Unplug the interface card assembly power cable (5 pin cable) from the drive.

5. Unplug the interface card assembly 50 pin data cable from the drive.
6. Unplug the remote front panel cable from the drive.
7. Remove the ISE bottom bracket by removing the two Phillips screws at the rubber shock bushings that secure the bracket to the chassis (Figure 3-15).

**NOTE:** *Take careful note of the orientation and routing of the remote front panel cable.*

**Figure 3-15: Removing the Top and Bottom Brackets of a 5.25-inch EF-Series ISE**

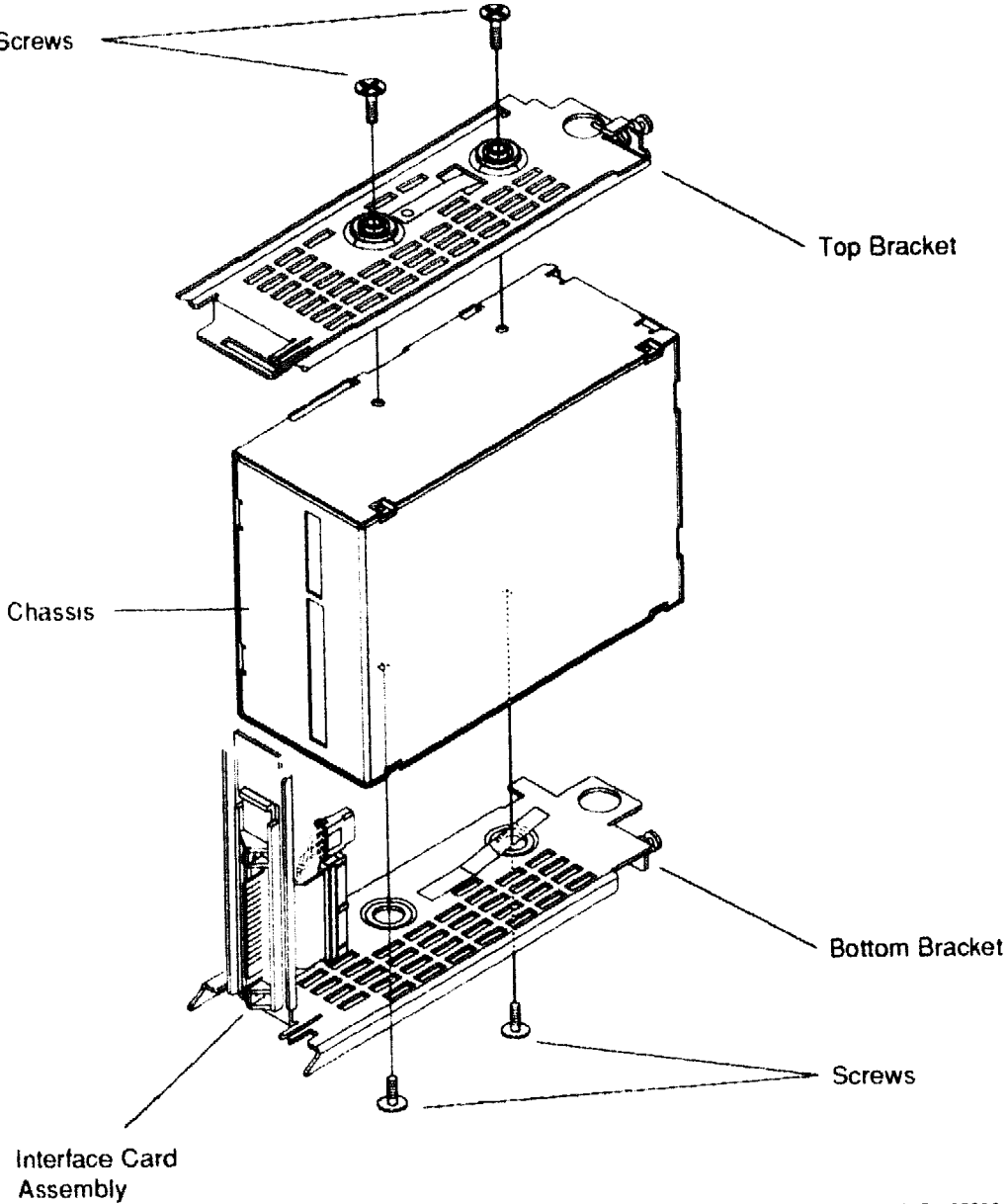

MLO-009303

### 3.3.8.2 Replacing the Battery Pack in the Chassis

At this point, you have removed all the mounting components of the EF-series ISE. You are ready to partially disassemble the chassis that contains the battery pack and to then remove the battery pack. Complete the following steps to replace the battery pack:

1. With the controller module connectors facing you, place the chassis on the side that did not have the skid plate attached to it. The slots for the cable connectors should be toward the top of the chassis (Figure 3-16).
2. Remove the screws located on each side of the top of the chassis. (Figure 3-16) Put the screws aside.
3. Remove the top of the chassis (Figure 3-16) and set it aside.

**Figure 3-16: Removing the Top of the Chassis on a 5.25-inch EF-Series ISE**

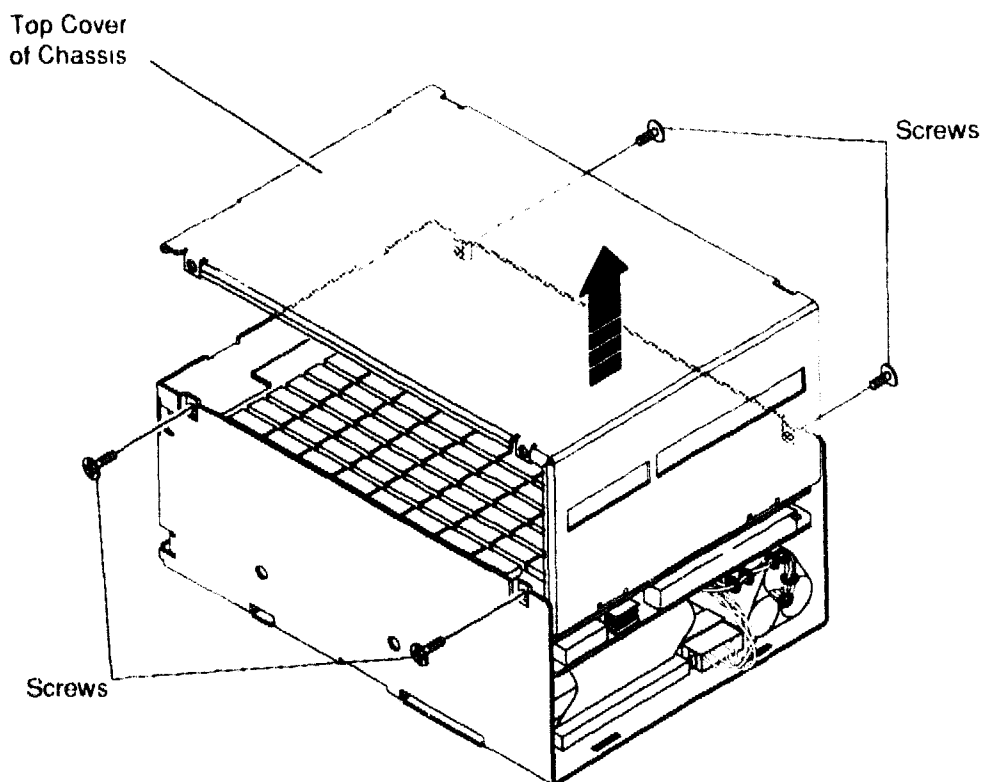

MLO-009304

4. Disconnect the battery connector from the battery harness connector (Figure 3-17).

5. Loosen the holding screw located on the right side of the chassis until you are able to gently pull the battery out of the chassis. (Figure 3-17)
6. Remove the battery.

**Figure 3-17: Removing the Battery of a 5.25-inch EF-Series ISE**

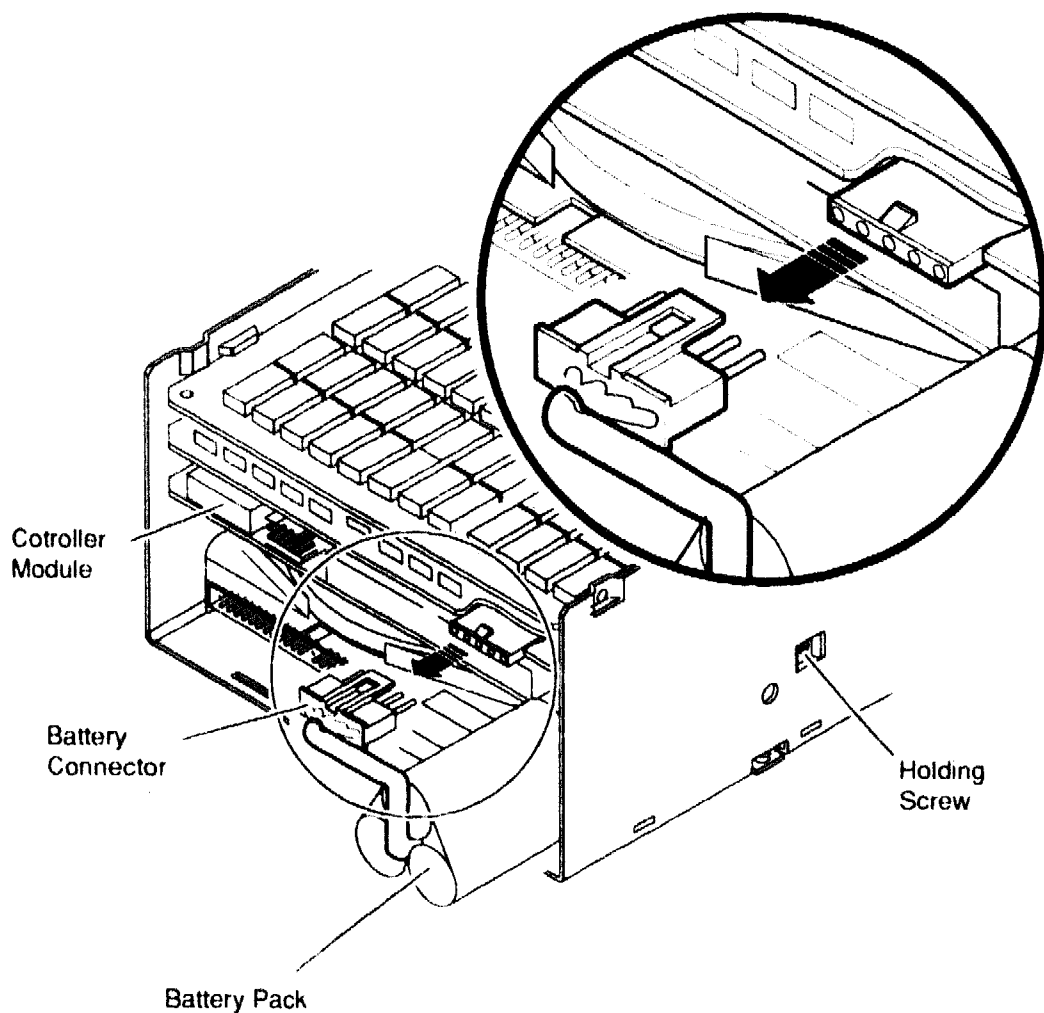

MLO 009305

7. Reverse the procedure to install a new battery pack.

## **3.4 Replacing the TLZ04 Tape Drive**

This section describes how to replace the TLZ04 tape drive. In addition, procedures are provided to replace the following individual FRUs that make up the mounting hardware for the ISE:

- Tape drive front panel module
- Interface card assembly
- ID cable

For information on troubleshooting strategy, error analysis, and diagnostics, refer to the TLZ04 tape drive service manual.

### 3.4.1 Remove the TLZ04 Tape Drive

Use the following instructions to remove a TLZ04 tape drive. Refer to Figure 3-18.

**CAUTION:** *Static electricity can damage integrated circuits. Use the wrist strap and antistatic mat found in the static-protective service kit (29-26246-00) when you work with the internal parts of a computer system.*

*Handle the tape drive with care. Dropping or bumping it can damage the drive. Carry or hold the drive by its metal brackets to avoid damaging the drive.*

**NOTE:** *If the cause of the drive failure is undetermined, inspect the connection of the ID cable and the TLZ04 front panel. The cable may not be connected securely, or the cable or connector may be defective.*

*If the front panel appears to be the problem, refer to Section 3.4.3 for instructions on replacing the TLZ04 front panel (54-204380-01). To replace the ID cable, continue removing the tape drive and then refer to Section 3.4.2 for instructions on replacing ID cable (17-01936-02).*

1. Unplug the ID cable from the TLZ04 front panel and set the front panel aside (Figure 3-18B).
2. Loosen the upper and lower captive screws that hold the drive in place (Figure 3-18C).
3. Using the upper and lower finger cutouts on the drive brackets, carefully pull the drive out of its backplane connector and slide the drive out of the enclosure. Support the weight of the drive at the underside of the lower bracket as the drive clears the enclosure (Figure 3-18C).

**NOTE:** *If the cause of the drive failure is undetermined, inspect the condition of the interface card and its associated cables and cable connections. Refer to Section 3.4.4 for instructions on replacing the interface card assembly (54-20136-03).*

4. Reverse the procedure to reinstall the TLZ04.

**Figure 3-18: Removing the TLZ04 Tape Drive**

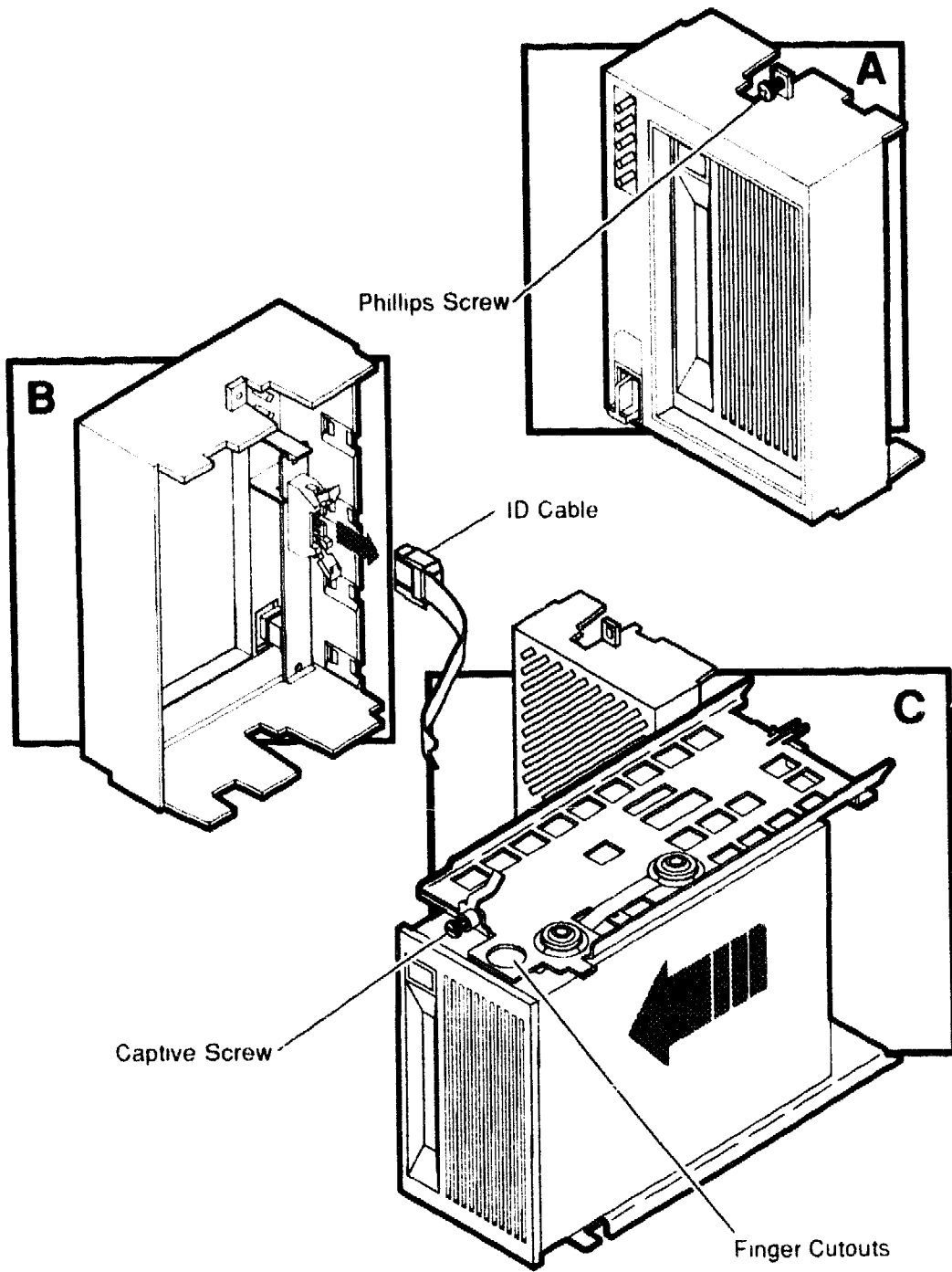

M.I.O 005795

## 3.4.2 Replacing the ID Cable

**NOTE:** *Observe cable routing to ensure that you route the cables properly when reassembling.*

To remove the ID cable:

1. Loosen the single captive Phillips screw that secures the TLZ04 front panel (Figure 3-18A).
2. Separate the TLZ04 front panel from the enclosure, being careful of the ID cable, which is connected to the TLZ04 front panel.
3. Unplug one end of the ID cable from the operator control panel (Figure 3-18B).
4. Remove the drive as described in Section 3.4.1.
5. Unplug the opposite end of the ID cable from the rear of the tape drive (Figure 3-19).
6. Reverse the procedure to install a new ID cable.

**Figure 3–19: Removing the ID Cable**

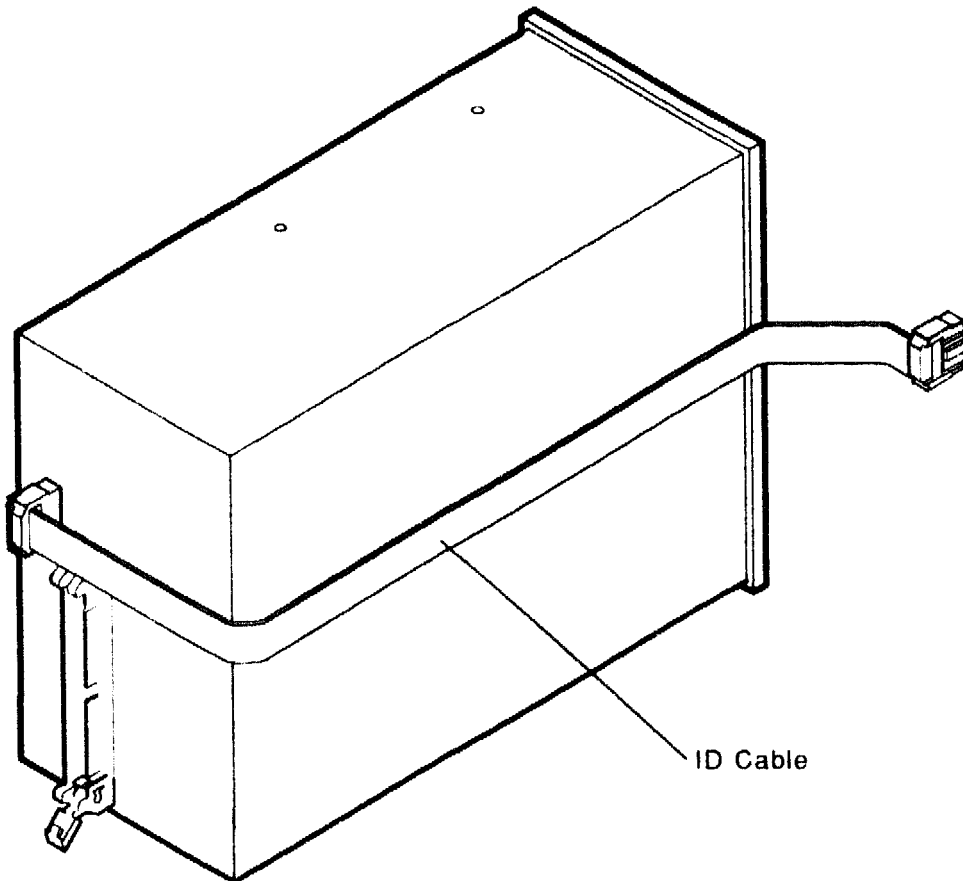

MLO-005796

### **3.4.3 Replacing the TLZ04 Front Panel Module**

Complete steps 1 and 2 in Section 3.4.1. Unplug the ID cable from the from the TLZ04 front panel. Use the following instructions to remove the TLZ04 front panel module (54–20438–01) and refer to Figure 3–20.

1. Remove the bus node ID plug on the TLZ04 front panel by pulling it straight out.
2. Lift the plastic tab that holds the front panel module in place to remove the module and then set the front panel aside (Figure 3–20).
3. Reverse the procedure to install a module.

**Figure 3–20: Removing the TLZ04 Front Panel Module**

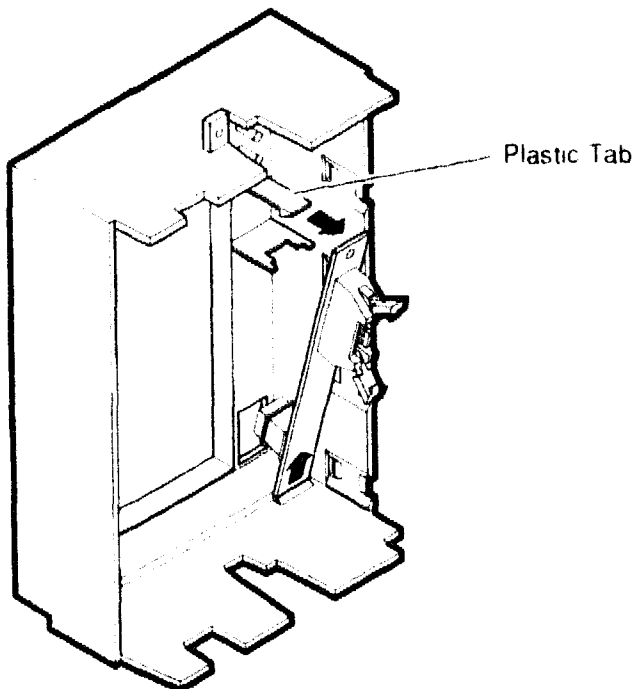

MLO 005797

### **3.4.4 Replacing the Interface Card Assembly**

Use the following instructions to replace the interface card assembly (54–20136–03). To remove the interface card assembly, first remove the top mounting bracket.

#### **3.4.4.1 Removing the Top Mounting Bracket**

This procedure assumes you have removed the drive as described in Section 3.4.1. Remove the drive top bracket as follows:

1. Place the drive on an antistatic mat.
2. Remove the two Phillips screws at the rubber shock bushings that secure the top bracket to the tape drive (Figure 3–21).

**Figure 3-21: Removing Bracket Screws**

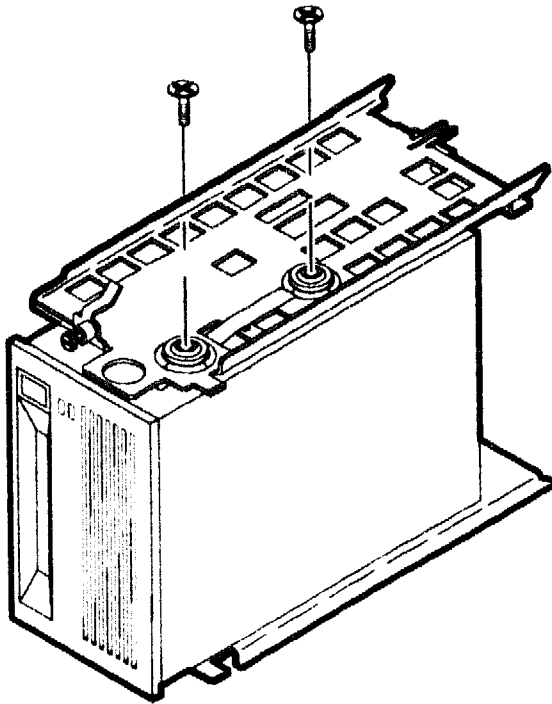

MLO-005799

3. Slide the interface card assembly up and lift off the top bracket (Figure 3-22). Put the bracket aside.

**Figure 3–22: Removing the Top Mounting Bracket**

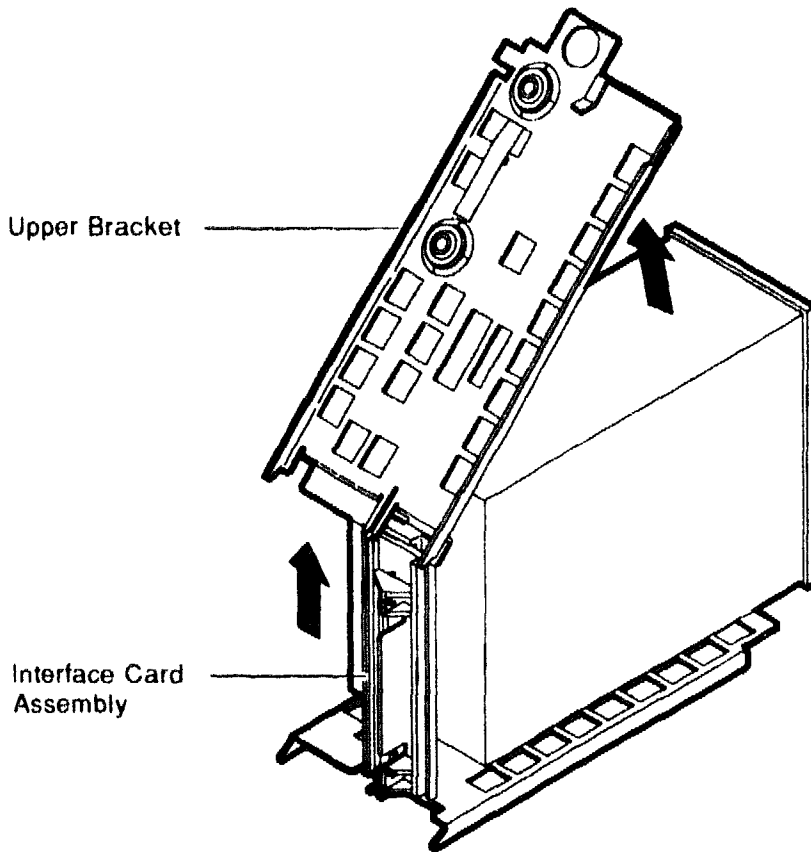

M.L.O. 005800

#### **3.4.4.2 Removing the Interface Card Assembly**

Remove the interface card assembly as follows:

1. Unplug the 4-pin power cable and the 50-pin signal cable from their connectors on the drive controller module.

**NOTE:** *Observe cable routing to ensure that you route the cables properly when reassembling.*

2. Lift and remove the plastic interface card assembly, being careful to guide the cables through the cutout in the metal bracket (Figure 3–23).
3. To remove the plastic assembly from the interface card, remove the two Phillips screws that hold it in place (Figure 3–23). Put the screws aside.

4. Set the new interface card on the plastic assembly so that the power harness is on the side nearest the flange. Use the two Phillips screws to secure the interface card to the plastic assembly.

**NOTE:** *Tighten the screws only until they are securely fastened (3 inch-pounds).*

5. Reverse the procedure to install the interface card assembly.

**Figure 3-23: Removing the Interface Card Assembly**

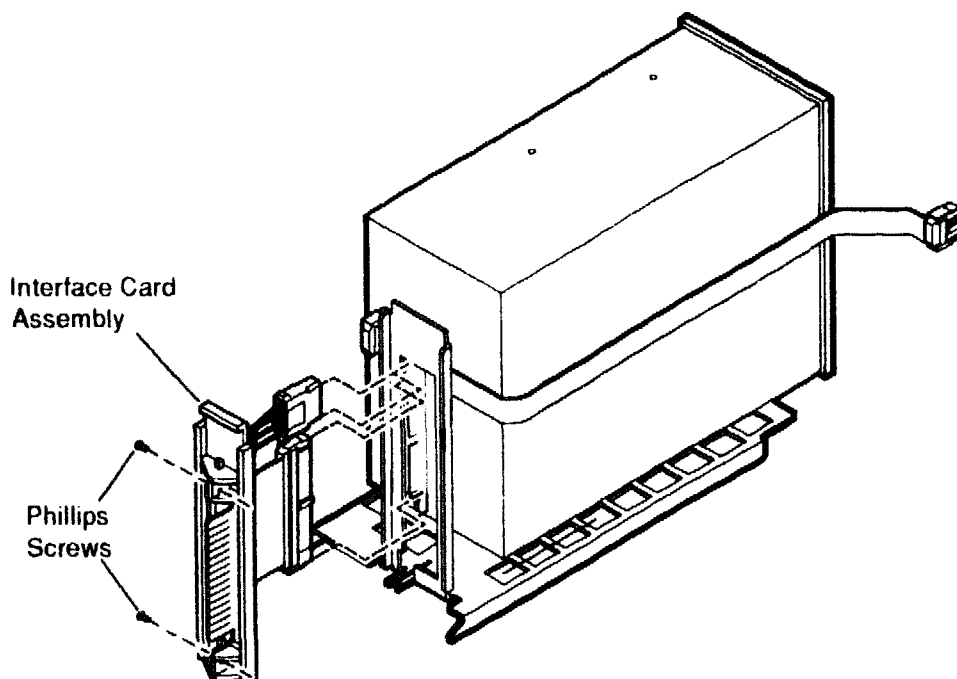

MLO 005801

### **3.4.5 Replacing the Tape Drive**

To remove the tape drive, you first remove the tape drive as described in Section 3.4.1 and the top bracket as described in Section 3.4.4.1. At this point the following procedures have to be completed:

1. Unplug the power cable (4 pin) and the data cable (50 pin) from the tape drive controller module.
2. Unplug the ID cable from the tape drive.
3. Remove the bottom mounting bracket by removing the two Phillips screws at the rubber shock bushings that secure the bottom bracket to the tape drive (Figure 3-24).

**Figure 3-24: Removing the Tape Drive**

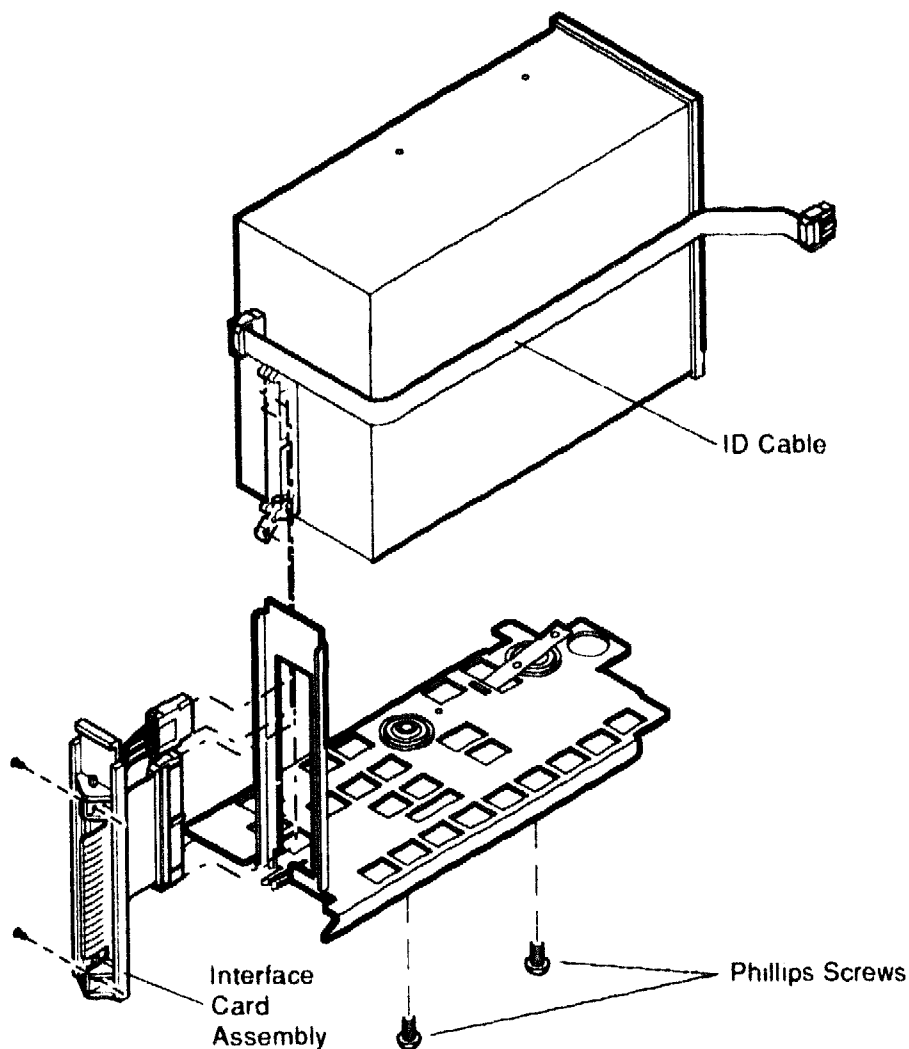

MLO-005802

4. Remove the tape drive and set it aside.
5. Reverse the procedure to install a tape drive.

### **Installation Notes**

When you install the new drive be sure to complete the following:

1. Align the new storage device in the same orientation as the original device, left side down.

2. When reinstalling the top bracket, lift the bracket's rear slot over the flange of the plastic interface card assembly, and then over the tab at the back of the bottom bracket. Both the tab and the flange must be inside the rear slot of the top bracket.
3. Make sure that the grounding foil is in place under the front mounting screw on both the top and the bottom brackets.

### 3.5 Replacing a TK-Series Tape Drive

This section describes how to replace the TK-series tape drive. In addition, procedures are provided to replace the Interface card assembly.

Remove a tape drive from the mass storage cavity as follows:

1. Loosen the captive screw at the top of the tape drive's front panel (Figure 3-25 Remove the tape drive front panel and set it aside.

**Figure 3-25: Releasing TK-Series Captive Screws**

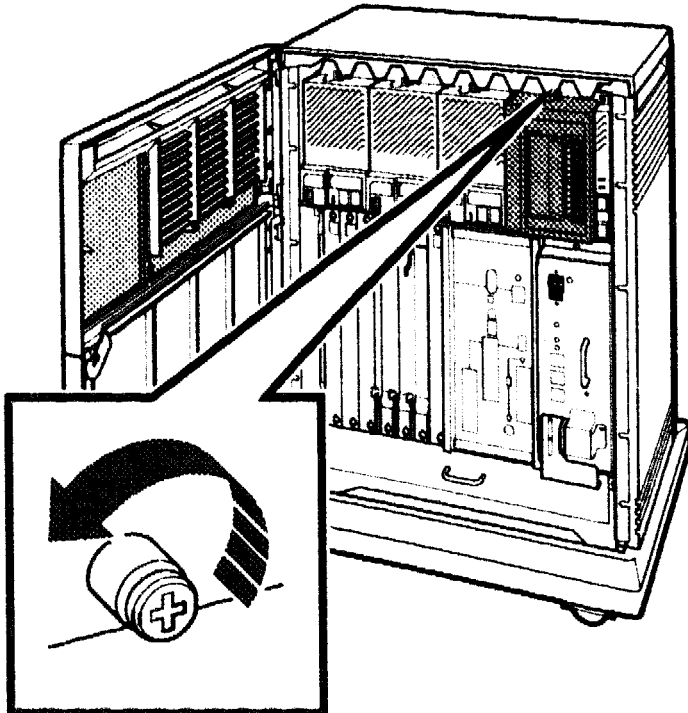

MLO 004215

2. Release the tape drive from the enclosure by loosening the captive screws above and below the drive unit.

3. Slowly slide the tape drive unit partially out of the BA430/BA440 enclosure until you can access the data cable at the rear of the drive (Figure 3-26).

**Figure 3-26: Removing a TK-Series Drive Unit**

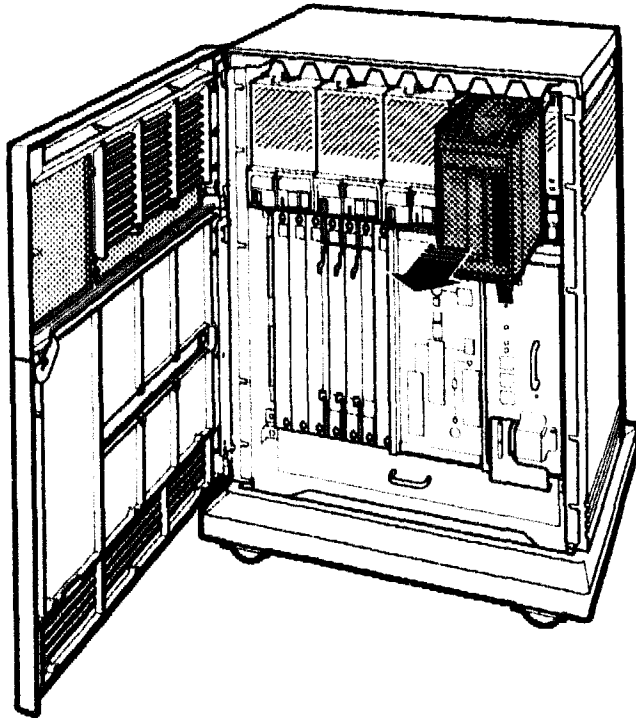

MLO 004216

4. Note the orientation of the data cable. Disconnect the data cable from the tape drive (Figure 3-30).
5. Continue to slide the tape drive unit out of the BA430/BA440 enclosure (Figure 3-26) and lay it left side down on an antistatic mat.

### **3.5.1 Replace the Interface Card**

This section describes how to replace the interface card on a TK-series drive.

1. These instructions assume that the procedures in Section 3.5 have been completed.
2. Remove the top bracket, by removing the two Phillips screws at the rubber shock bushings that secure the bracket to the tape drive. Push up the plastic flange of the interface card assembly, lift the top bracket's rear slot over the plastic flange Figure 3-27.

**Figure 3-27: Removing the Top Mounting Bracket**

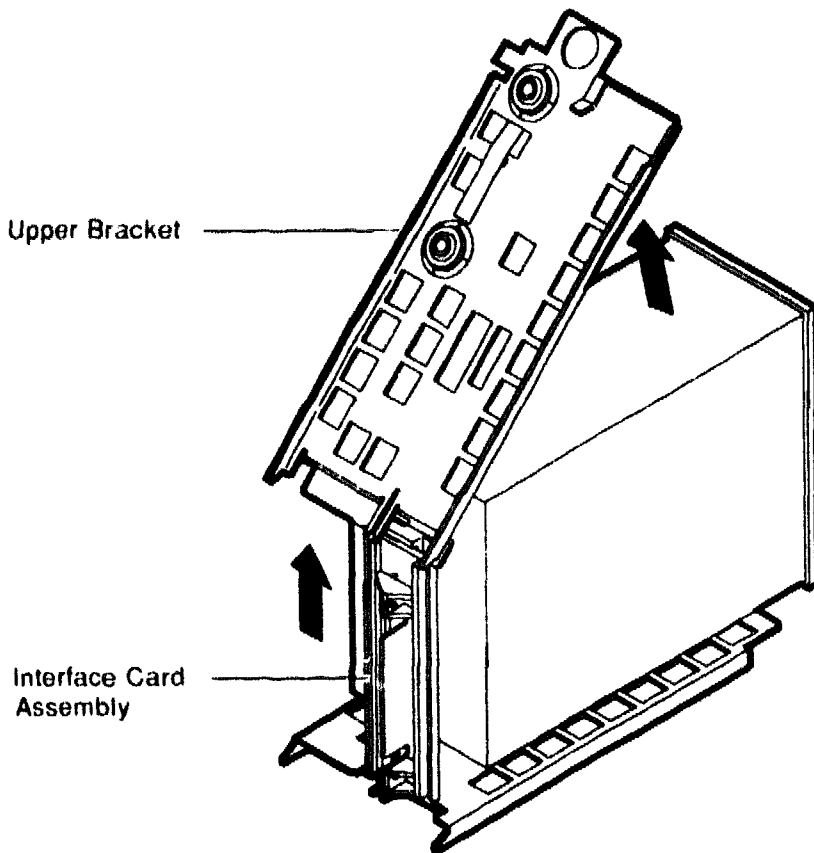

MLO-005800

Place the bracket and the mounting screws aside, you will need them when you install the new drive

3. Unplug the interface card power cable (4 pin cable) from the tape drive controller module.
4. Carefully remove the interface card from the bottom bracket.
5. To remove the plastic assembly from the interface card, remove the two Phillips screws that hold it in place (Figure 3-23). Put the screws aside.
6. Set the new interface card on the plastic assembly so that the power harness is on the side nearest the flange. Use the two Phillips screws to secure the interface card to the plastic assembly.

**NOTE:** *Tighten the screws only until they are securely fastened (3 inch-pounds).*

7. Reverse this procedure to install an interface card.

### 3.5.2 Replace the TK-Series Tape Drive

This procedure assumes you have removed the drive from the mass storage cavity as described in Section 3.5. At this point the following procedures must be completed to replace a TK-series tape drive:

1. Place the drive on an antistatic mat.
2. Remove the two Phillips screws at the rubber shock bushings that secure the top bracket to the tape drive (Figure 3-28).

**Figure 3-28: Removing Bracket Screws**

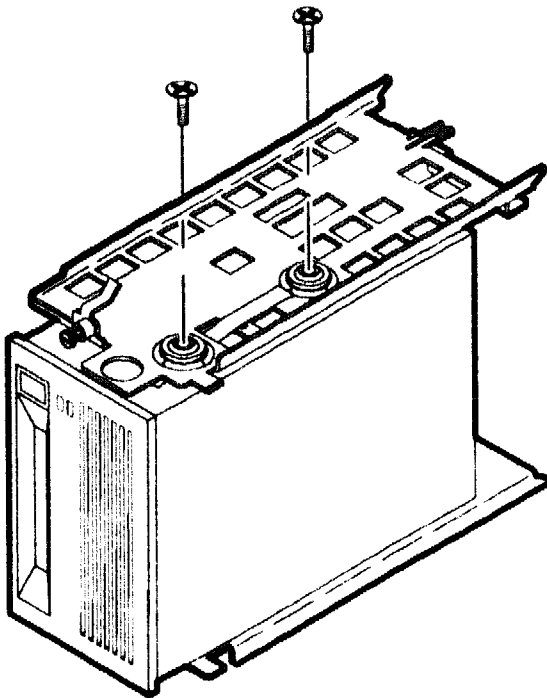

MLO 005799

3. Slide the interface card assembly up and lift off the top bracket (Figure 3-29). Put the bracket aside.

**Figure 3-29: Removing the Top Mounting Bracket**

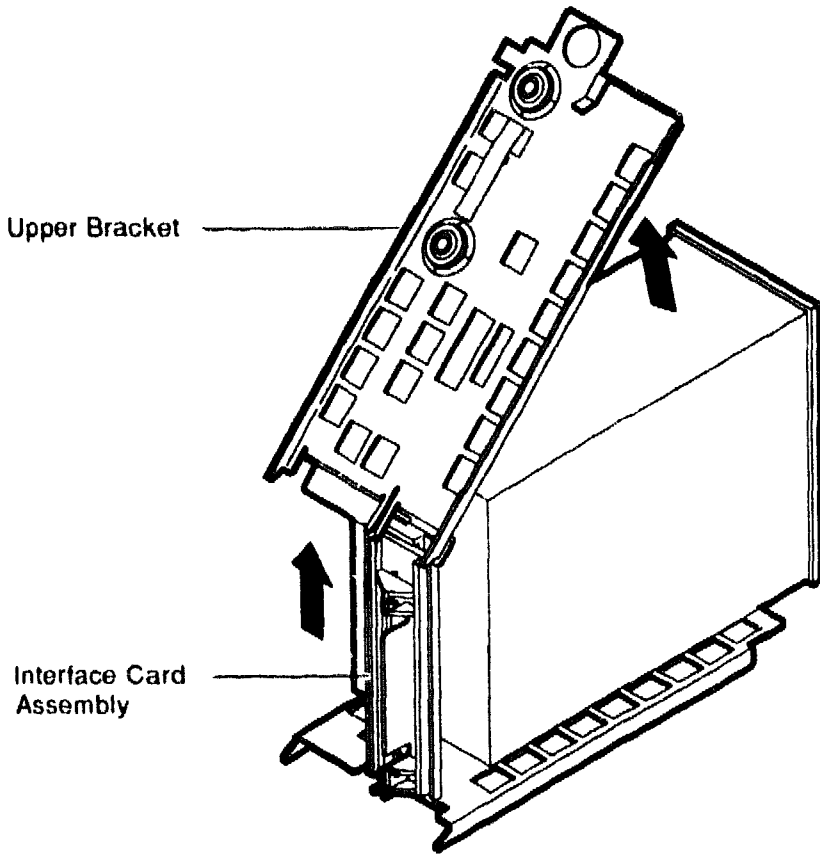

MLO-005800

4. Unplug the interface card power cable (4 pin cable) from the tape drive controller module.
5. Remove the bottom bracket, by removing the two Phillips screws at the rubber shock bushings that secure the bracket to the tape drive. Place the bracket and the mounting screws aside, you will need them when you install the new drive
6. Remove the drive and set it aside.
7. Reverse the procedure to install a new tape drive.

## **Installation Notes**

When you install the new drive be sure to complete the following:

1. If the new TK-series tape drive unit is attached to a skid plate, you must remove the skid plate from the replacement drive and install the skid plate on the defective drive before returning the drive.
2. When replacing a TK-series drive, do not pinch the data cable at the rear of the tape drive (Figure 3-30). If you feel resistance when sliding the drive into the BA430/BA440 enclosure, remove the drive unit and check that the cable is clear.
3. Align the new storage device in the same orientation as the original device, left side down.
4. When reinstalling the top bracket, lift the bracket's rear slot over the flange of the plastic interface card assembly, and then over the tab at the back of the bottom bracket. Both the tab and the flange must be inside the rear slot of the top bracket.
5. Make sure that the grounding foil is in place under the front mounting screw on both the top and the bottom brackets.

**Figure 3–30: Removing a TK-Series Cable**

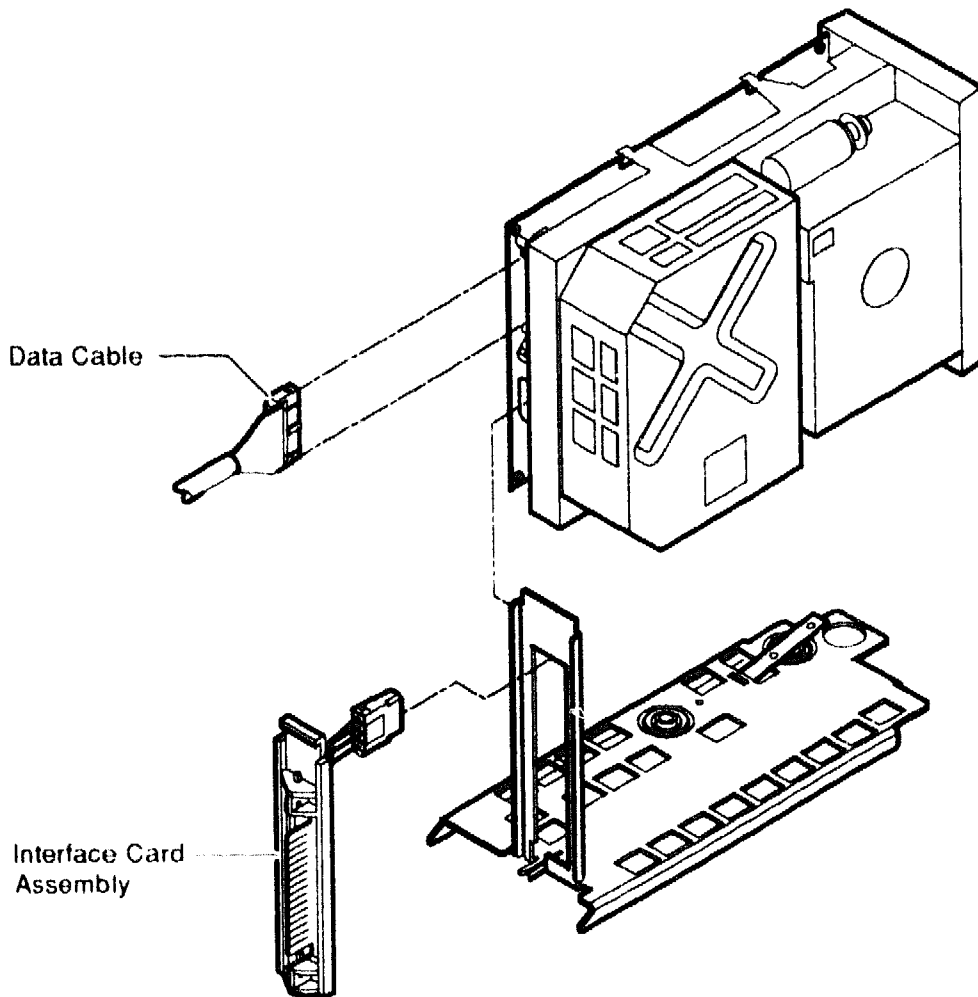

MLO-004228

### **3.6 Replacing a TF-Series Tape Drive**

This section describes how to replace the TLZ04 tape drive. In addition, procedures are provided to replace the following individual FRUs that make up the mounting hardware for the ISE:

- Tape drive front panel module
- Interface card assembly

Remove a TF-series tape drive from the mass storage cavity as follows:

1. Loosen the the single captive Phillips screw that secures the TF85 front panel (Figure 3-31A).
2. Separate the TF85 front panel from the enclosure, then disconnect the ID cable from the TF85 drive module (Figure 3-31B) and set the panel aside.
3. Loosen the upper and lower captive screws that hold the drive in place (Figure 3-31C).
4. Using the upper and lower finger cutouts on the drive brackets, carefully pull the drive out of its backplane connector and slide the drive out of the enclosure. Support the weight of the drive at the underside of the lower bracket as it clears the enclosure (Figure 3-31C).

**Figure 3-31: Removing a TF-Series Drive Unit**

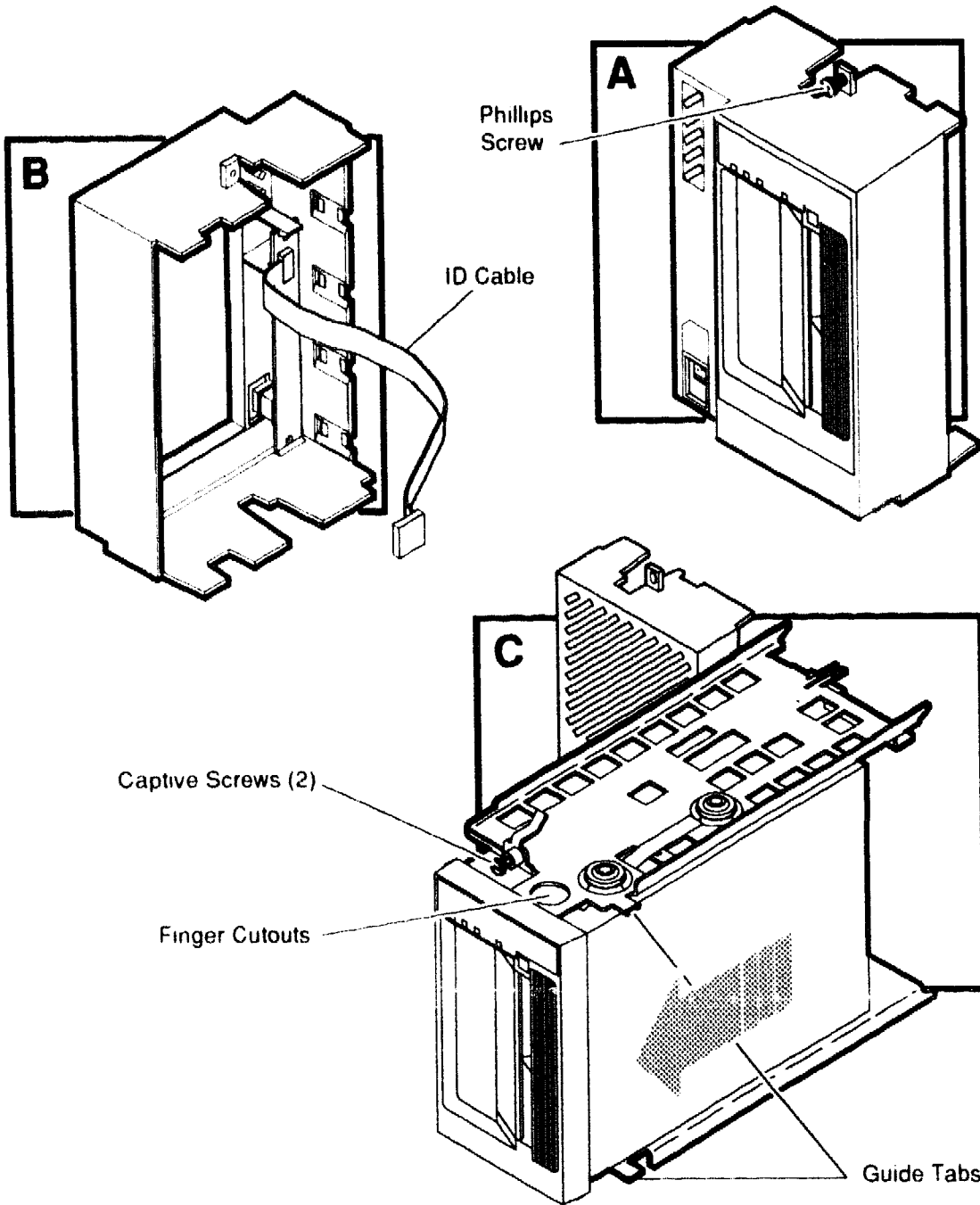

MLO-006703

5. Place the drive on an antistatic mat.

### 3.6.1 Replacing the TF-Series Front Panel Module

Complete steps 1 and 2 in Section 3.6. Unplug the ID cable from the front panel. Use the following instructions to remove the TF-series tape drive front panel module (54-20336-01) and refer to Figure 3-32.

1. Remove the bus node ID plug on the front panel by pulling it straight out.
2. Lift the plastic tab that holds the front panel module in place to remove the module and then set the front panel aside (Figure 3-32).
3. Reverse the procedure to install a module.

**Figure 3-32: Removing the TF-Series Front Panel Module**

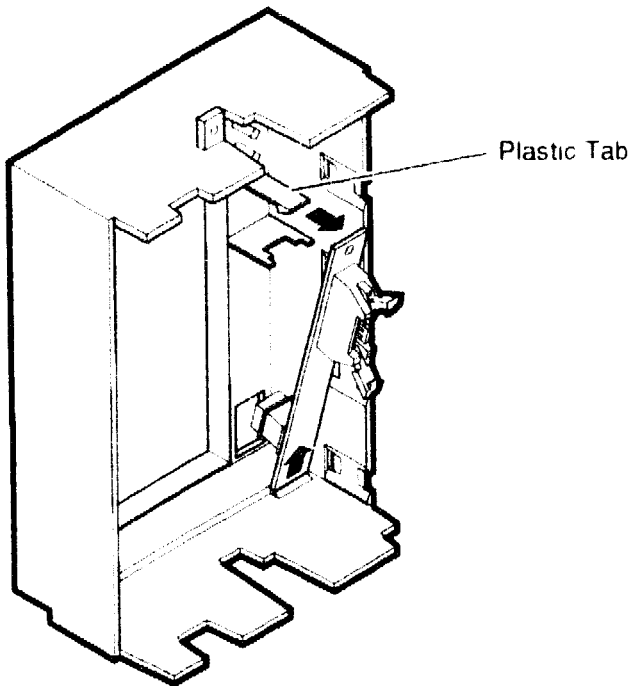

MLO-005797

### 3.6.2 Replacing the Interface Card Assembly

Use the following instructions to replace the interface card assembly (54-19787-02).

1. To remove the interface card assembly, you first remove the tape drive as described in Section 3.6

**Figure 3-33: Removing Bracket Screws**

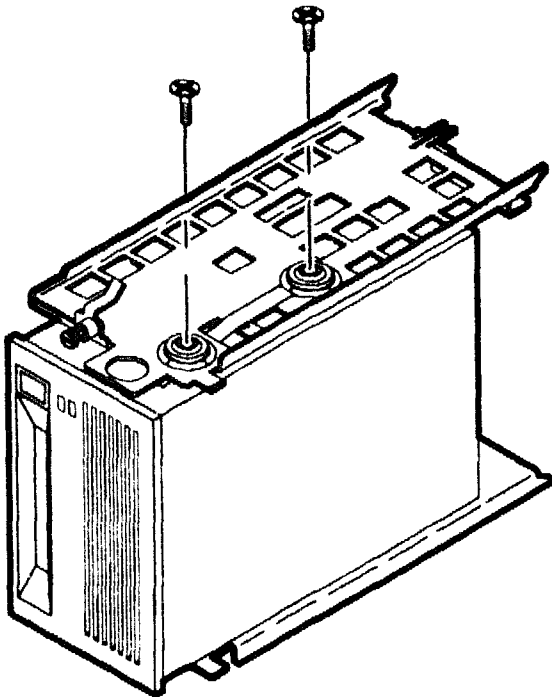

MLO-005799

2. Remove the top bracket, by removing the two Phillips screws at the rubber shock bushings that secure the bracket to the tape drive (Figure 3-33). Push up the plastic flange of the interface card assembly, lift the top bracket's rear slot over the plastic flange Figure 3-34.

**Figure 3-34: Removing the Top Mounting Bracket**

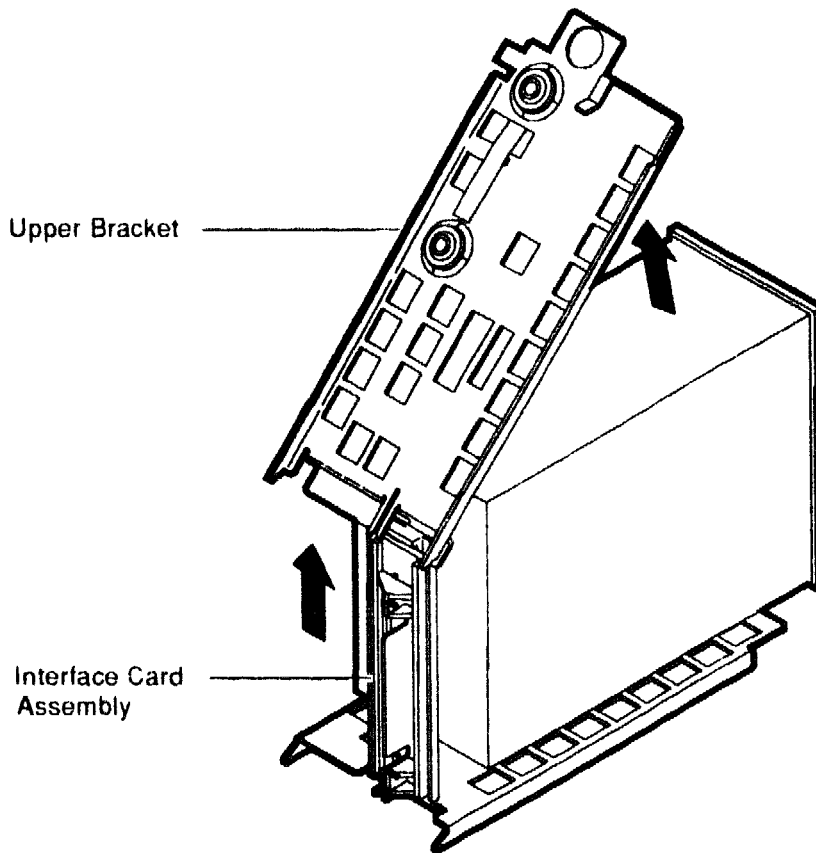

MLO 005800

Place the bracket and the mounting screws aside, you will need them when you install the new drive.

3. Unplug the two interface card power cables from their connectors on the tape drive. Unplug the 50 pin data cable.

**NOTE:** *Observe cable routing to ensure that you route the cables properly when reassembling.*

4. Lift and remove the plastic interface card assembly, being careful to guide the cables through the cutout in the metal bracket.
5. To remove the plastic assembly from the interface card, remove the two Phillips screws that hold it in place (Figure 3-35). Put the screws aside.

6. Set the new interface card on the plastic assembly so that the power harness is on the side nearest the flange. Use the two Phillips screws to secure the interface card to the plastic assembly.

**NOTE:** *Tighten the screws only until they are securely fastened (3 inch-pounds).*

7. Reverse the procedure to install the interface card assembly.

**Figure 3-35: Removing the Interface Card Assembly**

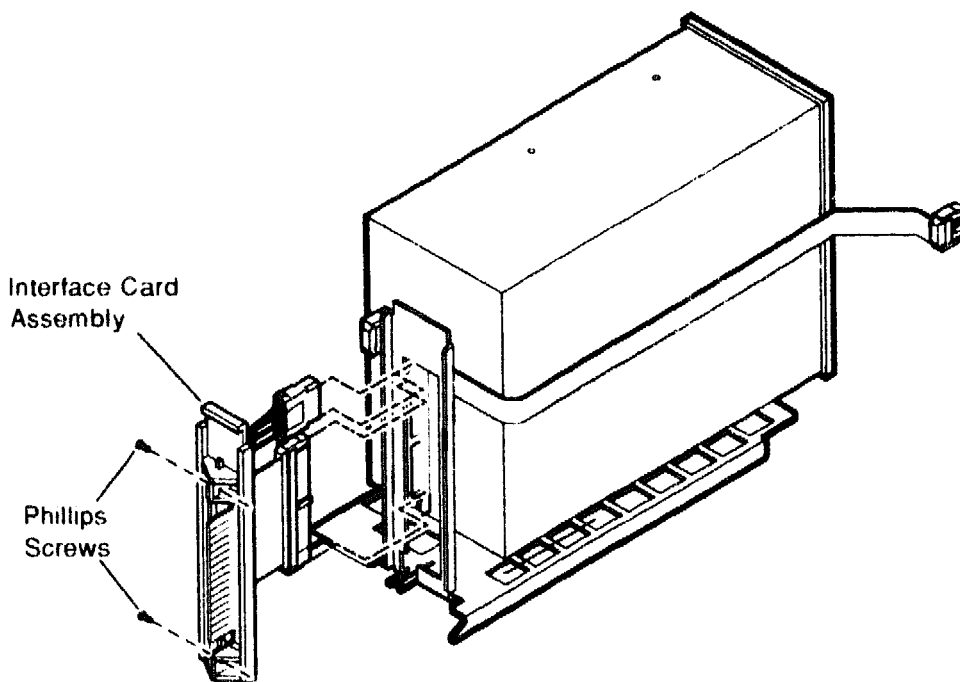

MLO-005801

### 3.6.3 Replacing the Tape Drive

This section describes how to replace the tape drive:

1. To replace the tape drive, you first remove the tape drive as described in Section 3.6
2. Remove the top bracket, by removing the two Phillips screws at the rubber shock bushings that secure the bracket to the tape drive. Push up the plastic flange of the interface card assembly, lift the top bracket's rear slot over the plastic flange Figure 3-36.

**Figure 3-36: Removing the Top Mounting Bracket**

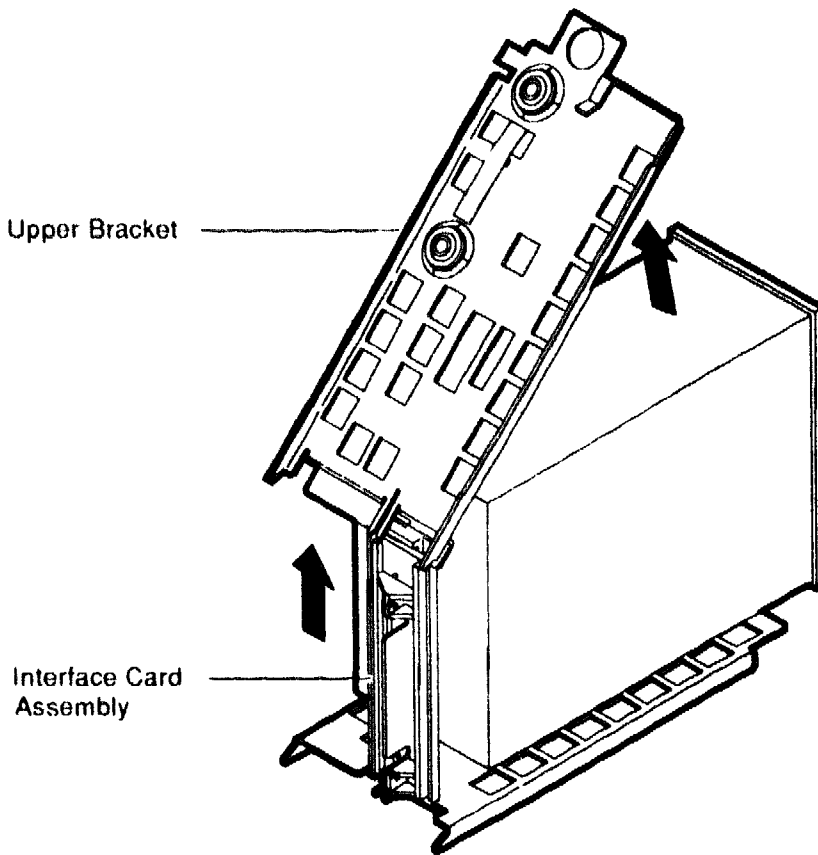

MLC-005800

Place the bracket and the mounting screws aside, you will need them when you install the new drive.

3. Disconnect the two interface card power cables and the interface card data cable.
4. Remove the bottom bracket, by removing the two Phillips screws at the rubber shock bushings that secure the bracket to the tape drive. Place the bracket and the mounting screws aside, you will need them when you install the new drive
5. Remove the drive and set it aside.
6. Reverse the procedure to install a new tape drive.

## **Installation Notes**

When you install the new drive be sure to complete the following:

1. Align the new storage device in the same orientation as the original device, left side down.
2. When reinstalling the top bracket, lift the bracket's rear slot over the flange of the plastic interface card assembly, and then over the tab at the back of the bottom bracket. Both the tab and the flange must be inside the rear slot of the top bracket.
3. Make sure that the grounding foil is in place under the front mounting screw on the top and bottom brackets.

## **3.7 Removing the System Control Panel (SCP)**

To remove the system control panel (Figure 3-37) perform the following steps:

1. Open the upper access door.
2. Release the top captive screw securing the assembly.
3. Separate the SCP from the enclosure, being careful of the interface cable that is connected to the SCP.
4. Detach the interface cable.
5. Remove the SCP.
6. Reverse the procedure to install a new SCP.

**Figure 3-37: Removing the System Control Panel (SCP)**

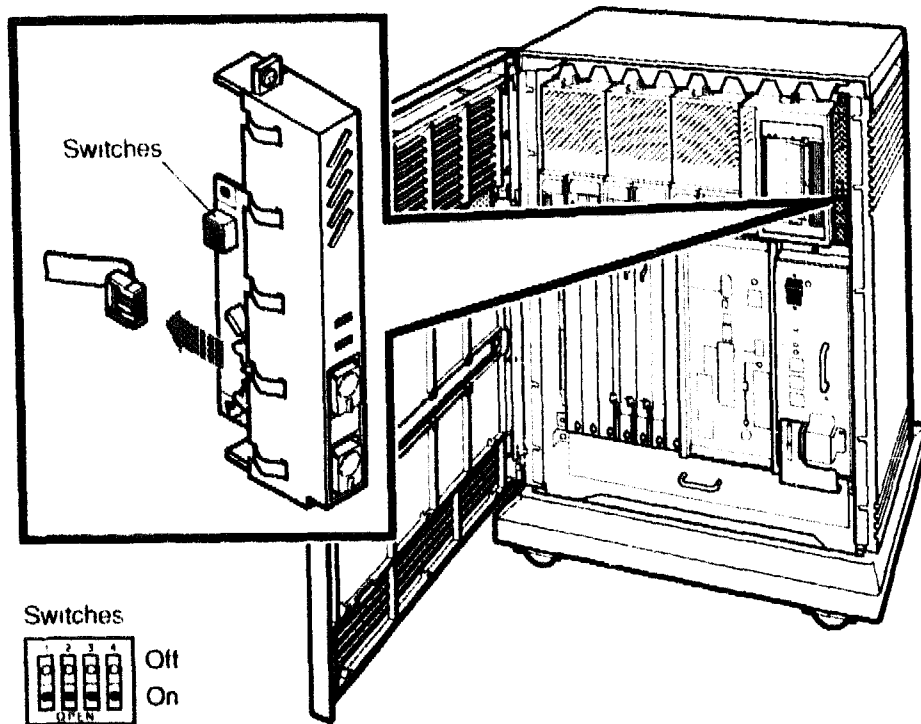

MLO-004217

### **Installation Note**

When the four switch pack switches are set to the on position, the system controls function normally. If the switch pack switches are all positioned off, the system controls on the panel are disabled.

## **3.8 Removing the Power Supply**

The BA430/BA440 enclosure has one power supply. To remove the power supply, follow the procedure carefully.

### **Danger High Voltage**



This warning symbol indicates risk of electric shock.

**WARNING:** *The power cable must be removed from the wall outlet to disconnect ac power. The circuit breaker Power switch is NOT a disconnect device.*

**WARNING:** *The power supply stores an electrical charge which, if not discharged correctly, could cause physical harm. Use the following procedure to discharge the power supply before removing it:*

1. Set the Power switch to off (0). Unplug the power cable from the wall outlet.
2. Remove the power cable from the power supply (Figure 3–38).

**Figure 3–38: Removing the Power Supply Cable**

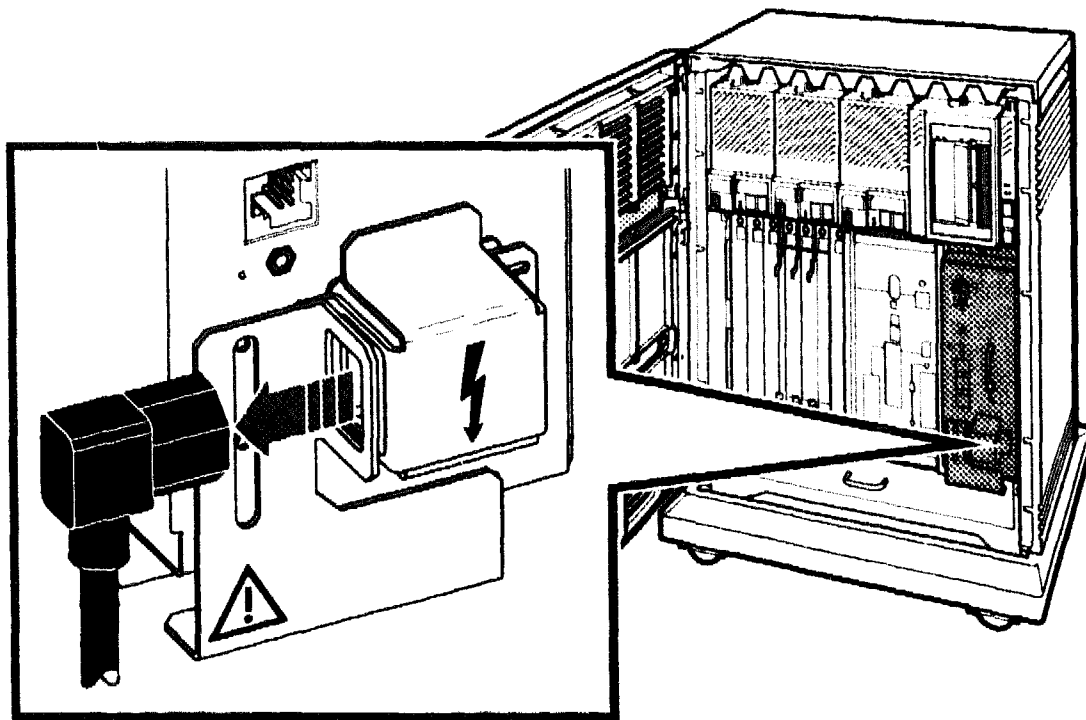

MLO-004219

3. Remove the ground wire (if any) and power control bus cables (if any).
4. Loosen the top captive screw on the power supply.
5. Discharge the power supply by raising the cover plate up against the bottom of the power supply and holding it there for at least 45 seconds

(Figure 3–39). The sliding plate depresses the discharge button, located at the bottom of the power supply.

**WARNING:** *Hold the discharge plate in the up position for at least 45 seconds after removing the ac power cable. This discharges the system and makes the power supply safe to handle.*

**Figure 3–39: Discharging the Power Supply**

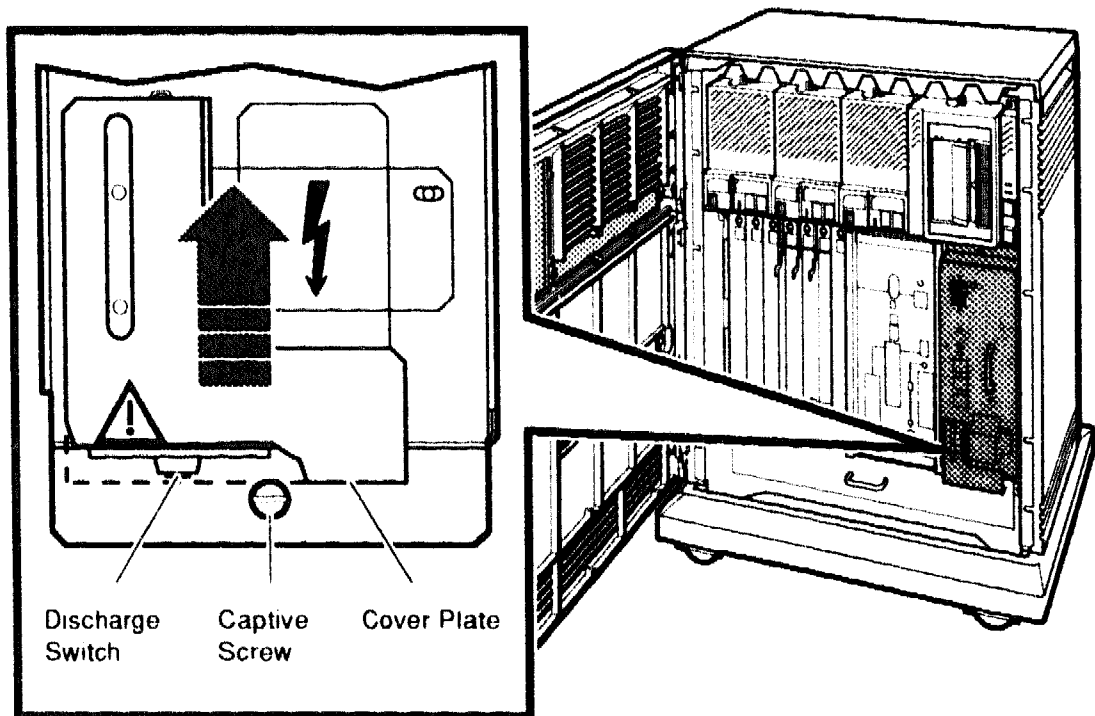

MLO-004229

6. Release the bottom captive screw on the power supply while pushing the cover plate up to expose the bottom screw (Figure 3–39).
7. Grasp the power supply handle with one hand and pull the power supply out from the backplane connection (Figure 3–40).
8. Remove the power supply. Be careful of the power supply weight.

**NOTE:** *A plate covers one fastener that holds the power supply to the BA430/BA440 enclosure in such a way that the power cable must be removed before this fastener can be disconnected. This fastener MUST*

*BE TIGHTENED when servicing is completed before replacing the power cable.*

9. Reverse the procedure to install a new power supply.

**Figure 3-40: Removing the Power Supply**

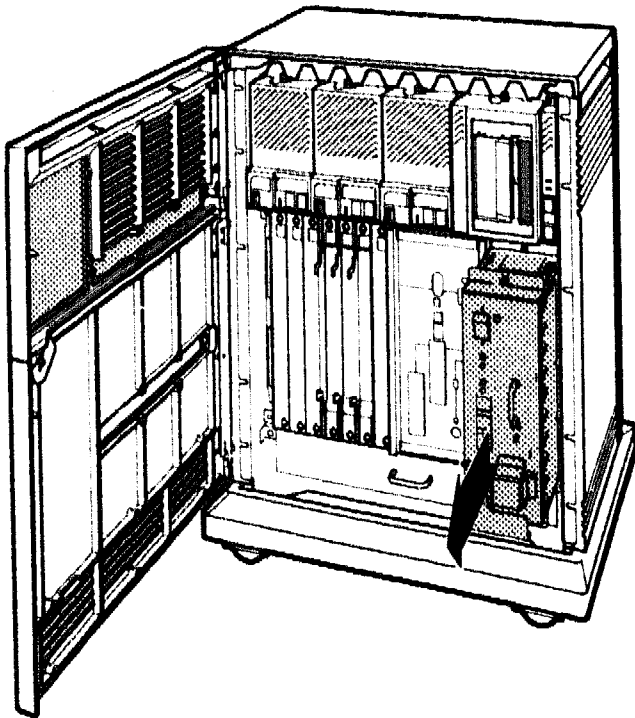

MLO-004226

### **Installation Notes**

When installing the power supply, make sure the top and bottom edges of the supply are aligned and mounted in the plastic guides in the enclosure.

Make sure the bottom screw is tightened.

## **3.9 Removing Fans**

A fan tray containing two 6-inch fans provides system cooling for the BA430/BA440 enclosure. The fans are controlled by a heat sensor that accurately varies the fan speed according to the system's temperature needs. The two fans are attached to the metal tray by a single mounting bracket. The fan tray slides under the card cage and fastens to the chassis by two thumb screws.

Complete the following steps to to remove the fans:

1. Open the lower access door.
2. Unplug the power cable from the power supply.
3. Remove or reroute any option cables away from the fan tray.
4. Loosen the two captive screws that hold the fan tray to the chassis.
5. Pull out the fan tray (Figure 3-41).

**Figure 3-41: Removing the Fan Tray**

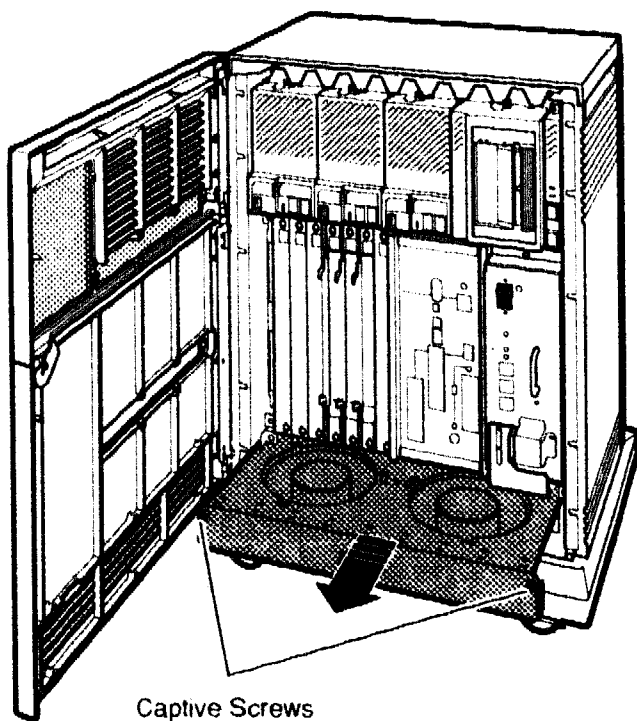

MLO 004220

6. Disconnect the dc power cable connector from the fan (Figure 3-42).
7. Remove the center screw and bracket that secures both fans to the tray (Figure 3-42).

**Figure 3-42: Removing the Fan Assembly**

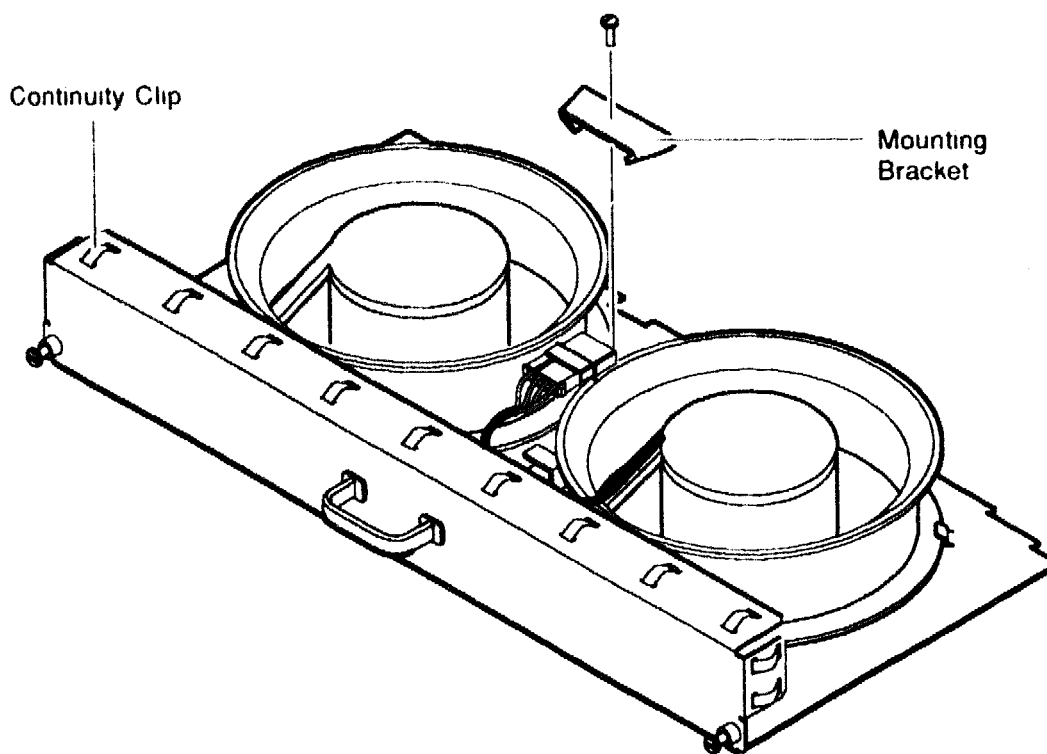

MLO-004221

8. Remove the fan(s).

**NOTE:** *It is recommended that fans be replaced in sets (or pairs).*

9. Reverse the procedure to install new fan(s).

### **3.10 Removing a BA430/BA440 Backplane**

This section covers the removal procedures for both the BA440 backplane (54-19354-01) and the BA430 backplane (54-20181-01).

**NOTE:** *It is not necessary to totally remove all option units, subassemblies, and connector cables from the enclosure, as long as all subassemblies, cable connectors and modules are disconnected from the backplane.*

*Label all ISEs with their bus node ID number to keep the appropriate ID plug with the correct ISE.*

The backplane is the only part of the BA430/BA440 enclosure that must be removed from the rear. To remove the backplane, follow the steps listed below:

1. Unlock and open both doors.
2. Remove the upper door by swinging it out more than 90 degrees and lifting it off its hinge bracket pins (Figure 3-43).
3. Remove the lower door by swinging it out more than 90 degrees and lifting it off its hinge bracket pins (Figure 3-43).
4. Remove the hinge bracket on the left by removing the five self-tapping screws.
5. Remove the door-latching bracket on the right by removing the three self tapping screws and one 6-32 screw. Remove the bracket and the two remaining self-tapping screws that secure the right side plastic panel to the sheet metal chassis frame.
6. Push the outer shell back and lift it off the chassis.

**Figure 3-43: Outer Shell Removal**

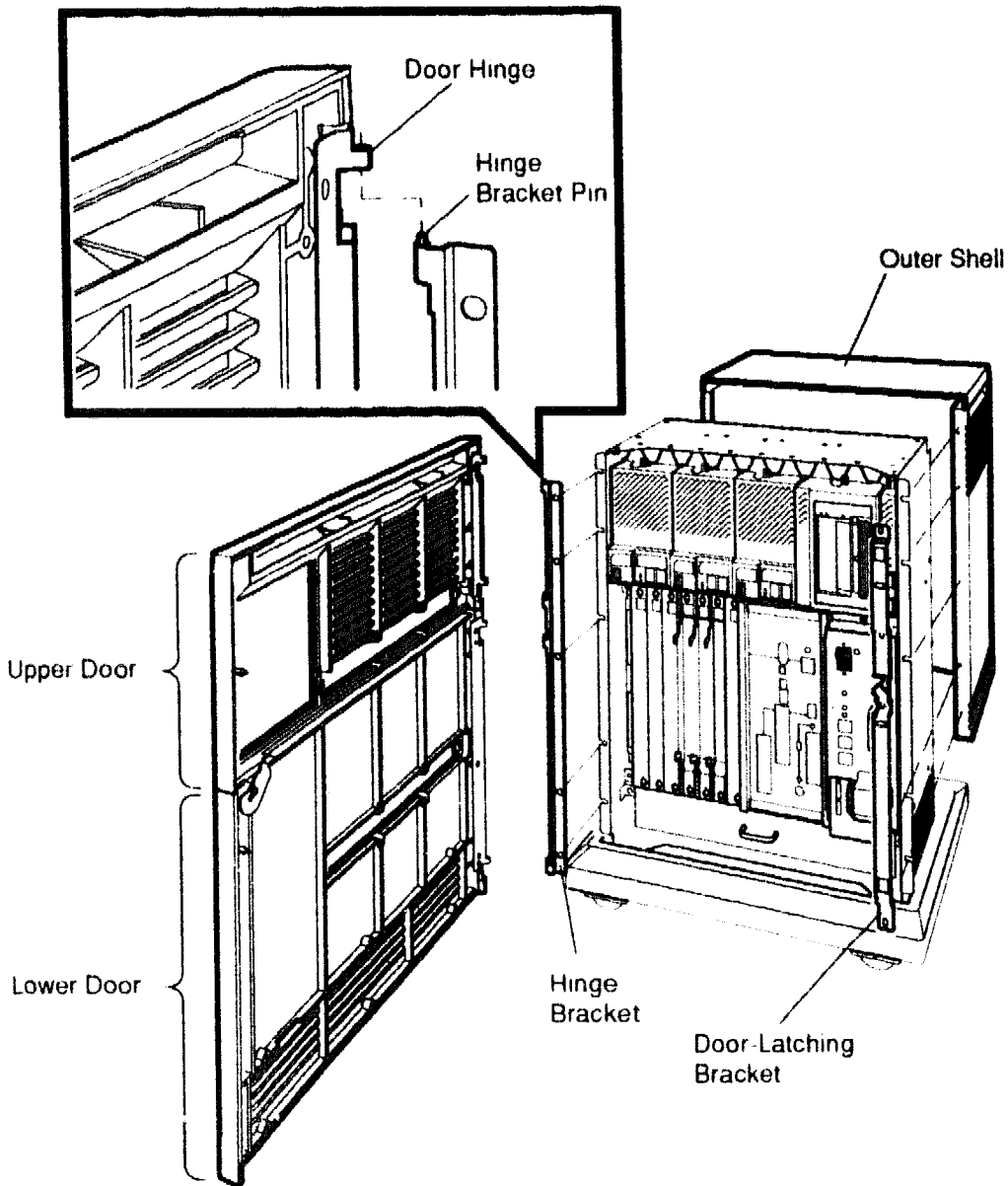

MLO-004222

7. Remove the power cable from the power supply (Figure 3-38).
8. Attach the static wrist strap to your wrist and the clip end of the static strap to the system chassis.

9. Remove ISEs, RF- and RZ-series Section 3.3, TLZ-series tape drives Section 3.4, TK-series tape drives Section 3.5, and the TF-series tape drives Section 3.6.
10. Disconnect the DSSI and SCSI bus cables (upper left of backplane) behind the ISE on the far left side (Figure 3-44).
11. Loosen the captive screw from the top of the System Control Panel (SCP). See Section 3.7. Remove the cable connector from the SCP slot (Figure 3-44).

**Figure 3-44: Bus Cable Locations (BA440)**

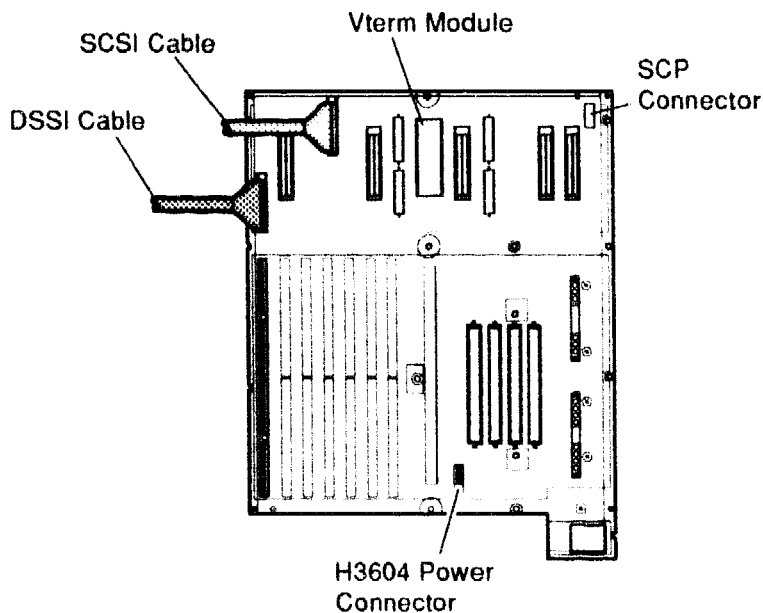

MLO 004223

12. Remove the power supply (Figure 3-40). See Section 3.8.

**NOTE:** *If you pull the power supply out completely, lay the power supply on its side.*

13. Label and disconnect all external cables from H3604 or H3602 modules.
14. Loosen the quarter turn screws and swing open the H3604 console module (BA440 only).
15. Loosen the quarter turn screws on H3602 (BA430 only) and separate the H3602 from the card cage being careful of the data cable connected to the H3602.

16. Disconnect the H3604 or H3602 internal cables. Place the console module on an antistatic mat .
17. Disconnect the power board for the H3604 from its special backplane slot (BA440 only).
18. Loosen the two screws securing the fan drawer. Pull the fan drawer out.
19. If removing the modules completely, write down the locations of all the system and option modules and cable connections. Then remove the modules and the cables.

For more information about removing modules and handles see Section 3.2.

20. Remove all of the screws on the rear panel (Figure 3-45).
21. Set the panel aside.

**Figure 3-45: Rear Panel Removal (BA430/BA440)**

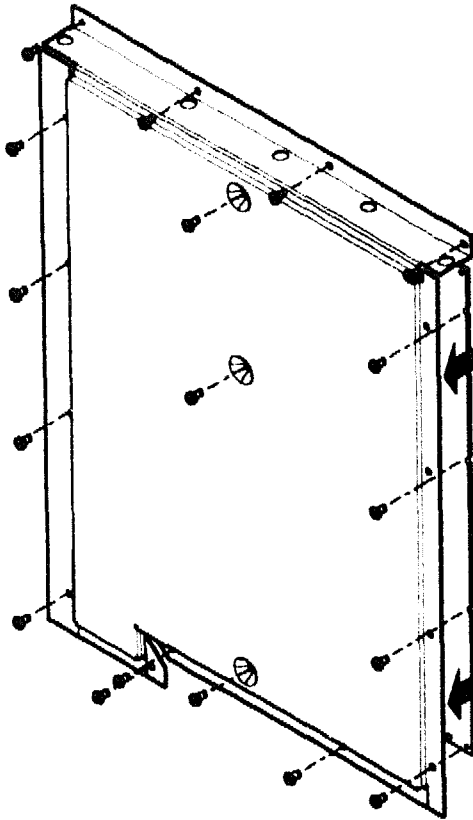

MLO-004224

22. Remove the three nuts from the middle of the backplane (Figure 3-46) (BA440 only).
23. Remove the three screws from the outside edge of the backplane (Figure 3-46).
24. Remove the backplane (be careful of the backplane weight).

**Figure 3-46: Removing a Backplane**

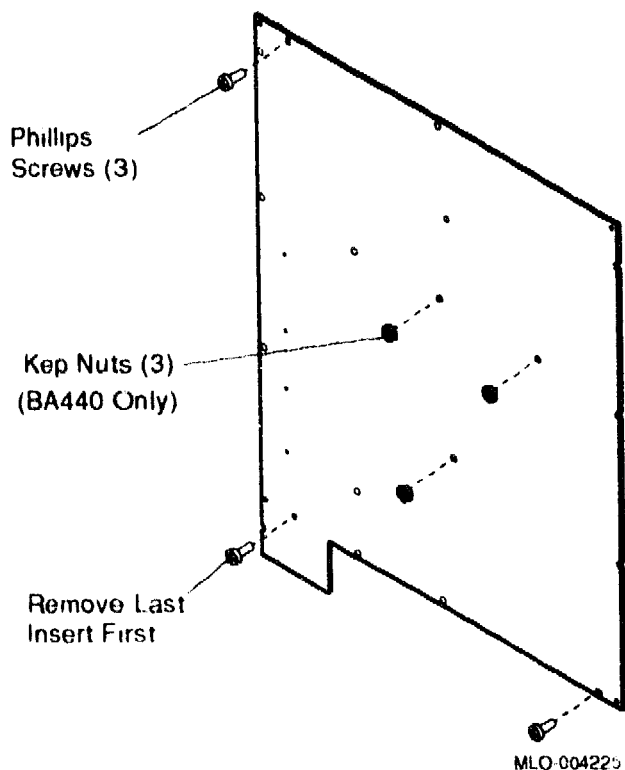

### 3.10.1 Installing a BA430/BA440 Backplane

To install a new backplane into the BA430/BA440 enclosure, complete the following sequence:

1. Open the new backplane bag (make sure the antistatic wrist strap is connected to the system chassis).
2. Align the new backplane assembly with the rear holes of the enclosure. Insert the two lower screws (left side first) and then the upper left screw to align the backplane against the card cage (Figure 3-46). For the BA440 Install the three nuts to the middle studs. Snug the nuts down hand tight.
3. Install the metal cover over the backplane using the screws previously removed, starting with the upper left, but do not tighten screws until all are installed properly, then tighten all screws.
4. Remove the static clip from the rear frame and clip it to the front of the enclosure.

5. Install the DSSI and SCSI bus cables (upper left of backplane) - (Figure 3-44).
6. Slide the fan drawer in and feel the drawer lock into the backplane connector. Tighten screws.
7. Install the connector end of the SCP cable to the backplane, and then reinstall the SCP to the extreme right side if it was removed.
8. Re-seat all ISEs and tape drives into their original bus slots, and tighten captive screws.
9. Connect ISE remote front panel cables and install each front panel (1 screw at the top). Be sure the front panel is attached to the proper ISE as the bus node ID plug would be affected.
10. Attach front panel cables, if applicable, then attach the tape drive front panel (1 screw at the top).
11. Insert the power supply and tighten the captive screws.
12. Insert the power board into its designated slot, between the memory and the CPU slots (BA440 only).
13. Install the CPU and memory modules.
14. Install the options into their original slots. Check the list of option module locations you made when you removed the options.
15. Install the H3604 console panel on its hinges. Connect the the cable from the power board to the H3604 (BA440 only).
16. Connect the data cable from the H3604 to the CPU module (BA440 only).
17. Connect the data cable from the the H3602 to the CPU module (BA430 only).
18. Connect all external cables to their original locations. Check the chart you made when you removed these cables.

### **3.10.2 Reinstalling the Outer Shell**

To reinstall the outer shell, use the following procedure.

1. Pull the outer shell over the enclosure and forward to the frame mounting holes as shown in Figure 3-47.
2. Install the hinge bracket on the left side with the five screws previously removed. Do not tighten screws at this time.

**NOTE:** *At this point the screws should be snug enough so that bracket can move, but not freely.*

3. Install the two screws into holes 2 and 4 on the right side (from the top of the enclosure chassis) and into the mating holes in the edge of the shell (before installing the latch bracket).
4. Install the latch bracket to the right front edge by installing the remaining three self-tapping screws and the one 6-32 screw. Insert the 6-32 screw first. This is the aligning screw. Do not tighten the screws at this time.

**NOTE:** *At this point the screws should be snug enough so that bracket can move, but not freely.*

5. Install the upper and lower doors. Position the doors at approximately 90 degrees (half open position) and hook the doors over their respective hinge bracket pin. The doors should drop into position.

**Figure 3-47: Door Installation**

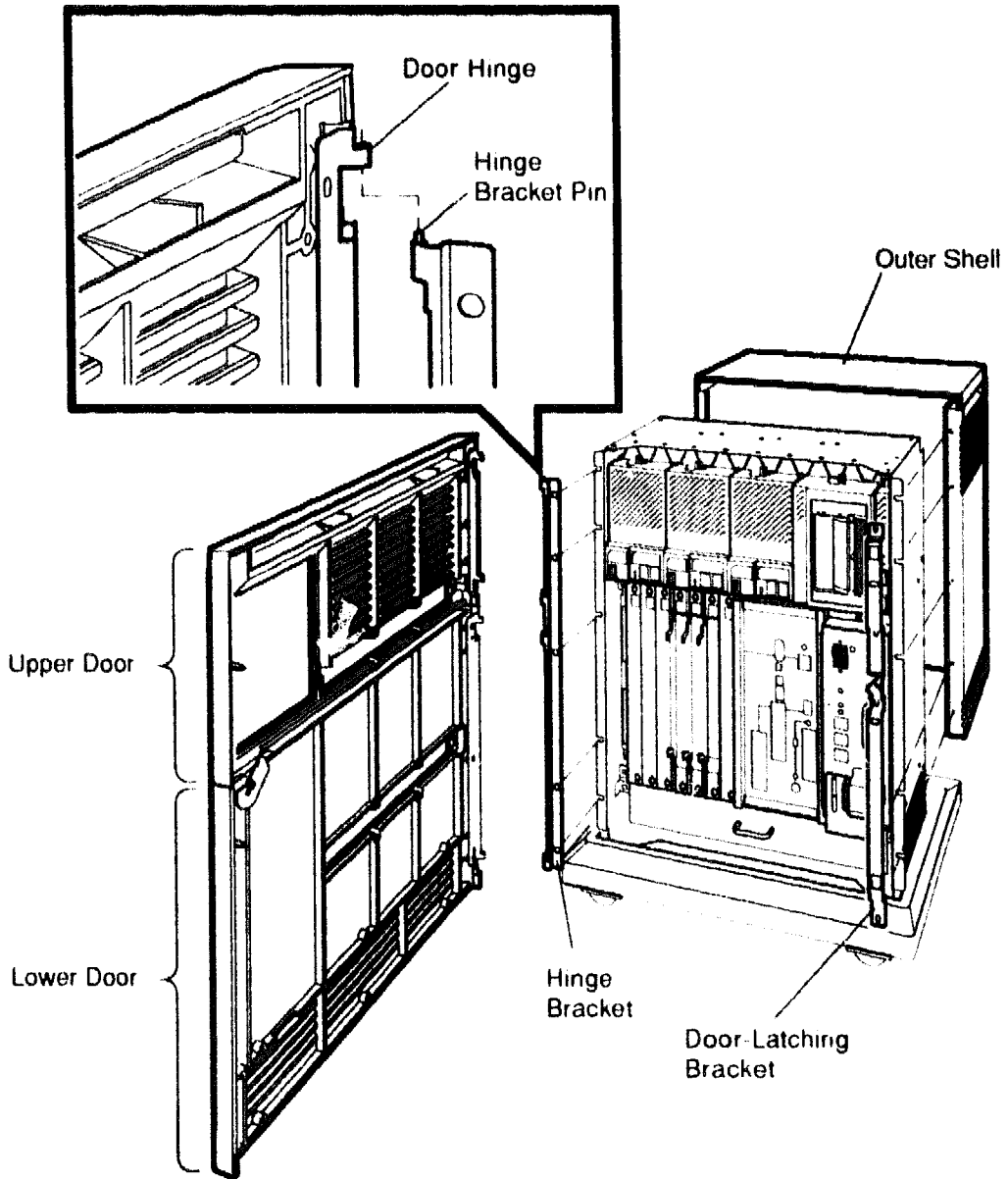

MLO-004222

**NOTE:** Check and adjust the door hinge bracket and latching bracket alignment to ensure the door latch is square with the enclosure and door locking latch clears the door latching bracket.

6. Tighten all screws.

7. **Reconnect the ac power cable.**
8. **Set system Power switch to on (1).**
9. **Run the system self-test and diagnostics to establish acceptable system operation.**
10. **Close and lock both doors.**

## Appendix A

# Related Documentation

---

The following documents contain information relating to systems and options supported for a BA430 and BA440 enclosure.

---

| Document Title  | Order Number |
|---|--------------|
| <hr/> <b>Module Options</b> <hr/>                             |              |
| CXA16 Technical Manual  | EK-CAB16-TM  |
| CXY08 Technical Manual  | EK-CXY08-TM  |
| DESQLA Ethernet Adapter Option Installation Guide             | EK-DEQNA-IN  |
| DESQLA Technical Manual                                       | EK-DEQNA-TM  |
| DPV11 Synchronous Controller Technical Manual                 | EK-DPV11-TM  |
| DPV11 Synchronous Controller User's Guide                     | EK-DPV11-UG  |
| DRV11-J Interface User's Manual                               | EK-DRV1J-UG  |
| DRV11 General Purpose DMA User's Guide                        | EK-DRVWA-UG  |
| EFxx-Series Solid State Disk User's Guide                     | EK-EF51x-UG  |
| IBQ01 BITBUS Controller Technical Manual                      | EK-IBQ01-TM  |
| IBQ01 BITBUS Controller User's Guide                          | EK-IBQ01-UG  |
| IBQ01 Option Installation Guide                               | EK-IBQ01-IN  |
| KDA50-Q CPU Module User's Guide                               | EK-KDA5Q-UG  |
| KFQSA Installation Guide                                      | EK-KFQSA-IN  |
| KMV11 Programmable Communications Controller User's Guide     | EK-KMV11-UG  |
| KMV11 Programmable Communications Controller Technical Manual | EK-KMV11-TM  |
| KZQSA Installation Guide                                      | EK-KZQSA-IG  |
| Microsystems and Options                                      | EK-192AA-MG  |

---

**Document Title****Order Number**

---

**Module Options**

---

|   |             |
|---|-------------|
| MRV11-D Universal PROM Module Users Guide | EK-MRV1D-UG |
| Q-Bus DMA Analog System User's Guide      | EK-AV11D-UG |

---

**Disk and Tape Drives**

---

|   |             |
|---|-------------|
| BA400-Series Enclosures Storage Devices Installation Procedures | EK-BA44A-IN |
| RA81 Disk Drive Service Manual                                  | EK-ORA81-SV |
| RA81 Disk Drive User's Guide                                    | EK-ORA81-UG |
| RA90 Disk Drive Service Manual                                  | EK-ORA90-SV |
| RA90 Disk Drive User's Guide                                    | EK-ORA90-UG |
| RA92 Disk Drive User's Guide                                    | EK-ORA92-UG |
| RF30/RF71 Integrated Storage Element User's Guide               | EK-RF71D-UG |
| RF31/RF72 Integrated Storage Element User's Guide               | EK-RF72D-UG |
| RF71 Integrated Storage Element User's Guide                    | EK-RF71D-UG |
| RF71 Service Guide  | EK-RF71D-SV |
| RF71 Integrated Storage Element User's Guide                    | EK-RF71D-UG |
| RF72 Integrated Storage Element User's Guide                    | EK-RF72D-UG |
| RRD40 Subsystem Optical Disc Drive Owner's Manual               | EK-RRD40-OM |
| RRD50 Subsystem Pocket Service Guide                            | EK-RRD50-PS |
| RRD50 Digital Disc Drive User's Guide                           | EK-RRD50-UG |
| TF85 Reference Card   | EK-OTF85-RC |
| TF857 Magazine Tape Subsystem Service Manual                    | EK-TK857-SM |
| TF85 Cartridge Tape Subsystem Owner's Manual                    | EK-TF85-OM  |
| TK50 Tape Drive Subsystem User's Guide                          | EK-LEP05-UG |
| TK70E-SF & TQK70-SF Installation Guide                          | EK-TK70E-IN |
| TK70 Tape Drive Owner's Manual                                  | EK-OTK70-OM |
| TLZ04 Dat Drive Owner's Manual                                  | EK-TLZ04-OM |

| <b>Document Title</b>                          | <b>Order Number</b> |
|--|---------------------|
| <b>Subsystems</b>                              |                     |
| TS05 Tape Transport Pocket Service Guide       | EK-TSV05-PS         |
| TS05 Tape Transport Subsystem Technical Manual | EK-TSV05-TM         |
| TS05 Tape Transport System User's Guide        | EK-TSV05-UG         |
| <b>CPUs</b>                                    |                     |
| BA400-Series Chassis Rackmount Installation    | EK-BA400-IN         |
| KA660 CPU System Maintenance                   | EK-398AA-MM         |
| KA670 CPU System Maintenance                   | EK-347AB-MG         |
| KN210 CPU System Maintenance                   | EK-329AA-MG         |
| KN220 CPU System Maintenance                   | EK-375AA-SM         |

# Index

---

## A

---

- Acoustics, 2-3
- Attached handles
  - removing modules, 3-7

## B

---

- Backplane
  - BA440
    - BA430, 1-40
  - grant continuity, 1-40
  - removal, 3-68
- Bus loads, 1-39

## C

---

- Configuration
  - capacity, 1-42
  - module order, 1-42
  - rules, 1-41
  - worksheet, 1-42
- Connectors, controls, and indicators, 1-31
- covers
  - single-width blank covers, 1-6
- Covers
  - double-width blank covers, 1-6
  - double-width CPU cover, 1-6
  - removing modules, 3-9
- Current draw
  - modules, 1-43

## D

---

- Disk ISE
  - maximum number supported, 1-10

- Double-width CPU cover, 1-6
  - H3602, 1-6
- DSSI interface, 1-13

## E

---

- EF-series integrate storage element, 1-11
- EF-series integrated storage elements, 1-13
- EF-series ISE
  - removing the mounting components, 3-30
  - replacing the battery pack, 3-33
- Electrical requirements, 2-4
- Enclosure
  - Keylock access, 1-3

## F

---

- Fans, 1-36
  - Fan Speed Control Disable (FSC), 1-37
  - removal, 3-64
- Filler panel, 1-8
- Fixed-disk ISE
  - maximum number supported, 1-16
- Front door
  - lock positions, 1-27
- Front panel assemblies, 1-14
- FRUs, 3-1
  - backplane, 3-68
  - fans, 3-64
  - list, 3-2
    - system-specific, 3-5
  - modules, 3-5
  - power supply, 3-61

## G

---

Grant continuity, 1-40

## H

---

H3600-SA, 1-7  
H3601-SA, 1-7  
H3602, 1-6  
H3602-SA, 1-7  
H3604, 1-6, 1-7  
H3604 console module, 1-27  
    connectors, controls, and  
    indicators, 1-31  
    key, 1-31  
    LEDs, 1-31  
    system controls, 1-31  
H3604 fuse, 1-28  
H3604-SA, 1-27  
H7874 power supply  
    switches  
        connectors  
        indicators, 1-35  
Handle  
    single-width flush handle, 1-6  
handles  
    ratchet ejectors, 1-6  
    single width recessed, 1-6  
Handles  
    types, 1-5  
Heat dissipation, 2-3  
Humidity values, 2-3

## I

---

Installing BA430/BA440 backplane,  
    3-72  
ISE  
    definition, 1-13

## K

---

Key, 1-31  
Keylock access  
    enclosure, 1-3

## L

---

LEDs, 1-31

## M

---

M7638 I/O module, 3-10  
M9715 Interface module, 3-10  
Module covers, 1-5  
Module handle and cover types, 1-6  
Module handles, 1-5  
Module order, 1-42  
Modules  
    power, bus loads, 1-43  
    removal, 3-5

## O

---

Overview, 1-1

## P

---

Physical dimensions  
    BA440 pedestal, 2-1  
power supply  
    shutdown sequence, 1-35  
Power supply, 1-32  
    minimum load, 1-49  
    removal, 3-61

## R

---

Ratchet ejector handles  
    removing modules, 3-6  
ratchet ejectors, 1-6  
Remove a storage device on a 3.5-  
    inch RF-series ISE  
    remove the top outside bracket  
    from the ISE, 3-27  
Remove the interface card 54-19787-  
    03 on a 3.5-inch RF-series  
    ISE  
    remove the top outside bracket  
    from the ISE, 3-20

Removing BA430/BA440 backplane, 3-66

Removing EF-, RF-, and RZ-series ISE from mass storage cavity, 3-11

Removing modules  
attached handles, 3-7  
ratchet ejector handles, 3-6

Removing Modules  
covers, 3-9

Removing the power supply, 3-61

Removing the System Control Panel (SCP), 3-60

Replace the interface card  
3.5-inch RF-series ISE, 3-21  
3.5-inch RF-Series ISEs, 3-20

Replace the TK-series  
tape drive, 3-49

Replacing a storage device  
5.25-inch RF- and RZ-series, 3-25  
3.5-inch RF-series, 3-27

Replacing a TK-series Tape Drive, 3-46

Replacing EF-, RF-, and RZ-series ISEs, 3-11

Replacing TF-series tape drive, 3-52

Replacing the interface card  
5.25-inch EF-, RF-, and RZ-series, 3-16

Replacing the ISE front pane module EF-, RF-, and RZ-series, 3-15

Replacing the remote front panel cable  
5.25-inch RF- and RZ-series ISEs, 3-23  
on a 3.5 inch RF-series ISE, 3-15

Replacing the TF-series  
front panel module, 3-55  
interface card assembly, 3-56  
tape drive, 3-58

Replacing the TK-series  
interface card, 3-47

Replacing the TLZ04  
front panel module, 3-39  
ID cable, 3-38

Replacing the TLZ04 (cont'd)  
Interface card assembly, 3-40  
tape drive, 3-44

RF-series 3.5-inch ISE, 1-11

RF-series integrated storage  
element, 1-11, 1-13, 1-14

RZ-series integrated storage  
element, 1-11, 1-14

## S

---

### SCP

see removing the System Control Panel

Shock-mounting hardware  
part numbers, 3-5

Shock-resistant supports  
part numbers, 3-5

single width recessed handle, 1-6

Single-width blank covers, 1-6

single-width flush handle, 1-6

Site preparation, 2-1

acoustics, 2-3

electrical requirements, 2-4

temperature and humidity, 2-3

Sliding tracks

part numbers, 3-5

Spacer panel (70-27414-01), 1-14

Special modules

M7638 I/O module, 3-10

M9715 interface module, 3-10

Static electricity, 2-2

Static precaution, 3-1

System controls, 1-31

## T

---

Tape drive

See TLZ04

maximum number supported,  
1-16

Temperature values, 2-3

TLZ04

removal of, 3-45

TLZ04 Tape drive  
replace, 3-35

## **U**

---

Unpacking the system, 2-5