

PowerRAC Chassis 320

Quick Start Installation Guide



www.api-networks.com

51-0040-1B

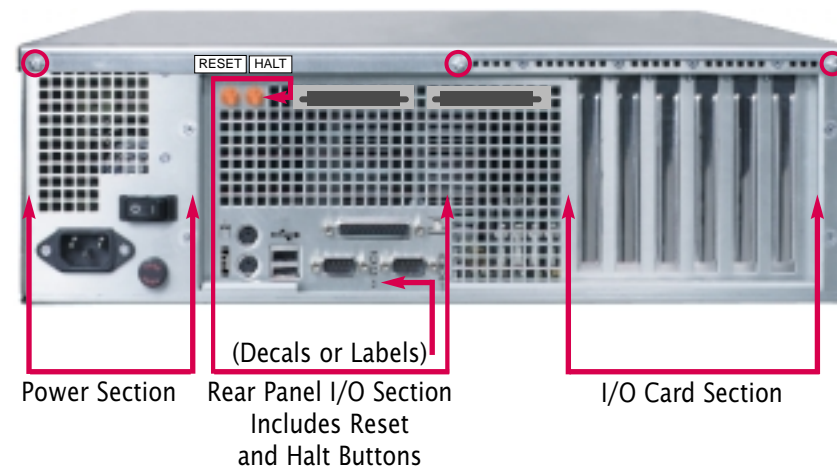
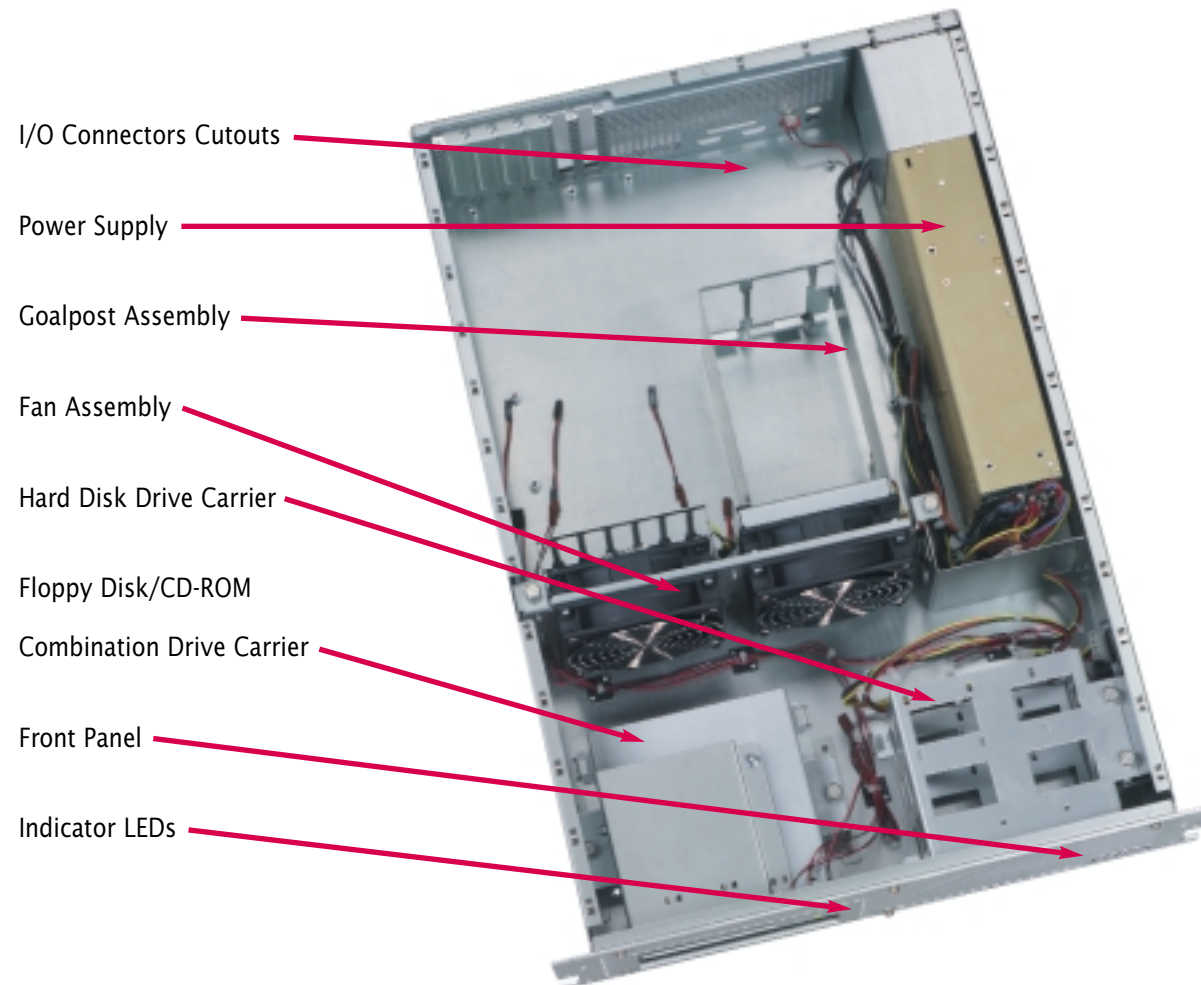

Chassis Specification

- **Height:** 5.22 in (132.6 mm) standard 3U height
- **Width:** Front panel, 19.00 in (482.6 mm) Body, 16.89 in (429.0 mm)
- **Depth:** With front panel, 25.16 in (639.1 mm)
- **Weight:** Not populated, 35 lbs (15.8 kg) Fully populated, ~50 lbs (22.7 kg)

PowerRAC Chassis 320 Parts (Not Shown)

- Rack-mount slide kit (see Panel G for details)
- Stick-on RFI Gasket
- Floppy Diskette power adapter cable
- 10 Screws (M4x8 mm Phillips pan head)

API NetWorks Required Components

- UP2000 Motherboard*
- Alpha Slot B Module (1 or 2)
- Documentation
 - UP2000 series *Quick Start Installation Guide*
 - UP2000 series *User Manual*

*Supports all UP2000/UP2000+ series motherboards

Customer Furnished Components

- Hard Disk Drive(s)
- Floppy Diskette Drive
- CD-ROM Drive
- Memory DIMMs
- PCI Cards
- Mouse
- Keyboard
- Serial, Parallel and USB Peripherals
- Custom Designed Front Panel Logo (1" sq.)
- Signal Cables for Drives
- External Connections
- Rack

Tools Required

- Torque driver: inch-pounds
- Phillips-head screwdriver: No. 2
- Flat-head screwdriver: No. 2
- Nut drivers: 5 mm, 9/32 inch and 11/32 inch

Note: API NetWorks documents and other information are available on our website: <http://www.api-networks.com>

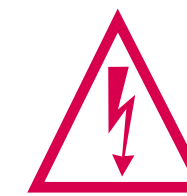

SAFETY CONSIDERATIONS

Fully assembled, the PowerRAC 320 weighs approximately 50 pounds. For personnel and equipment safety, API NetWorks recommends that two people work as a "rack mount" installation team. Ensure that the mechanical loading of the rack keeps it stable and unlikely to tip over. Do not block power supply vents or otherwise restrict airflow when installing the unit in a rack system. Be aware of the overall loading of the branch circuit before installing any equipment in a rack environment. The maximum ambient room temperature at which the unit can operate is 35° C (95° F).

B Remove Cover & Subassemblies

Step B1. Remove the Top Panel.

- B1.1) Remove and retain the three rear-mounted Phillips-head screws securing the panel to the chassis.
- B1.2) Slide the panel toward rear until the side slots clear the retention pins, then remove the panel.

Step B2. Remove Goalpost Assembly.

Remove and retain the four Phillips-head (M4x8mm) screws securing the assembly to the chassis, then remove assembly.



Step B3. Remove Fan Assembly.

Loosen the two spring-loaded captive screws securing the assembly to the chassis, then lift to remove assembly.



Step B4. Remove Hard Disk Drive Carrier.

- B4.1) Loosen the two spring-loaded captive screws securing the carrier to the chassis.
- B4.2) Slide the carrier toward rear until the tabs on the carrier bottom clear the slots on the chassis, then lift to remove carrier.



Step B5. Remove Floppy Disk/CD-ROM Combination Drive Carrier.

- B5.1) Loosen the two spring-loaded captive screws securing the carrier to the chassis.
- B5.2) Slide the carrier toward rear until the tabs on the carrier bottom clear the slots on the chassis, then lift to remove carrier.

C Assemble System

Step C1. Separate the Floppy Disk Drive holder from the CD-ROM Drive holder.

- C1.1) Loosen the four M7 nuts on the combination drive carrier.
- C1.2) Remove the two M7 nuts on the side of the combination drive carrier.



Step C2. On the data cable connector for the Floppy Disk Drive, break off the plastic tab that is used to key the ribbon cable insertion.

Step C3. Mount the CD-ROM Drive and the Floppy Drive into Combination Drive Carrier.

- C3.1) Before installing the CD-ROM drive into the holder, configure the drive to the master (MS) position per manufacturer's instructions.
- C3.2) Secure drives in place using the screws supplied with the drives. Tighten screws to 2 inch-pounds.

Step C4. Re-attach the Floppy Disk Drive holder to the CD-ROM Drive holder to form the combination drive carrier.

- C4.1) Install the two M7 nuts on the side of the carrier. Tighten to 17 inch-pounds.
- C4.2) Tighten the two M7 nuts on the top of the carrier to 17 inch-pounds.



Step C5. Install the Floppy Disk/CD-ROM Combination Drive Carrier into the chassis.

- C5.1) Slide the carrier forward until the tabs on the carrier bottom engage the slots on the chassis.
- C5.2) Tighten the two spring-loaded captive screws to secure the carrier to the chassis.

Step C6. Mount the hard disk drives into the Hard Disk Drive Carrier and secure in place using the screws supplied with the drives.

Step C7. Install the Hard Disk Drive Carrier into the chassis.

- C7.1) Slide the carrier forward until the tabs on the carrier bottom engage the slots on the chassis.
- C7.2) Tighten the two spring-loaded captive screws to secure the carrier to the chassis.

D Install Motherboard

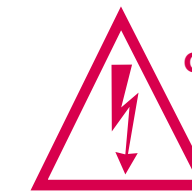

CAUTION: A grounding wrist strap must be worn and connected to the chassis prior to performing motherboard installation.

Step D1. Prior to installing the motherboard in the chassis:

- D1.1) Remove the six hexagonal standoffs (5 mm) from the rear panel I/O section on the motherboard.
- D1.2) If necessary, locate and set the appropriate jumpers on the motherboard to set CPU speed and L2 cache size per motherboard installation guide.
- D1.3) Install the stick-on RFI gasket on the inside of the chassis at the connector cutouts.

Step D2. Orient the motherboard so that the rear panel I/O connectors are aligned with the connector cutouts on the rear panel of the chassis.

- D2.1) Lower the motherboard into the chassis.
- D2.2) Align the 10 mounting holes on the motherboard with the associated standoffs on the chassis.

Note: Ensure no wires or connectors are routed between the motherboard and the chassis.

Step D3. At the rear panel of the chassis, loosely reinstall the six hexagonal standoffs (5 mm) at the rear panel I/O section on the motherboard.

Step D4. Loosely install 10 Phillips-head screws (M4x8mm) into the motherboard mounting holes.

Step D5. At the rear panel of the chassis, tighten the six hexagonal standoffs in the rear panel I/O section on the motherboard to 10 inch-pounds.

Step D6. Install the 10 Phillips-head screws (M4x8mm) at the motherboard mounting holes to secure it to the chassis. Tighten screws to 17 inch-pounds.



E Install Cables & Fan Assembly

Step E1. Attach the internal I/O and power connectors to the **motherboard** as described in the **motherboard** installation guide. Chassis cable connectors are described below.

E1.1) Power cable connectors:

- **Alpha Slot B Power** (4 x 1)
 - **ATX Power** (10 x 2)
 - **AUX ATX Power** (6 x 1)
- E1.2) Internal I/O cable connectors (labeled):
- **SPKR** = Speaker
 - **PWR** = Power Indicator/Power Good LED
 - **ACT** = SCSI Indicator/HDD Activity LED
 - **RST** = Reset Button
 - **HLT** = Halt Button**

**Enabled on the UP2000+ motherboard only.

Note: The internal I/O cable connectors in the chassis use the following wire-color convention:

- RED = GROUND**
- BLACK = SIGNAL**

Step E2. Install the signal cable from the IDE (or SE SCSI) disk port on the **motherboard** to the CD-ROM drive in the **Floppy Disk/CD-ROM Combination Drive Carrier**. Route signal cable to lie flat in area where the Fan Assembly will be installed.

Step E3. Install the signal cable from the LVD SCSI disk port (or LVD PCI bus) on the **motherboard** to the Hard Disk Drive in the **Hard Disk Drive Carrier**. Route signal cable to lie flat in area where the Fan Assembly will be installed.

Step E4. Install the signal cable from the Floppy disk port on the **motherboard** to the Floppy Disk Drive in the **Floppy Disk/CD-ROM Combination Drive Carrier**. Ensure the signal cable lies flat in area where the Fan Assembly will be installed.

Step E5. Install the adapter provided with chassis on the Floppy Disk Drive power cable connector, and then connect it to the drive.

Step E6. Connect the CD-ROM Drive and Hard Disk Drive power cables.

Step E7. Install the **Fan Assembly**.

- E7.1) Align the ends of the assembly with the support guides in chassis.
- E7.2) Lower the assembly into the chassis. Ensure the signal and power cabling does not inhibit assembly from fully seating.
- E7.3) Tighten the two spring-loaded captive screws to secure the assembly to the chassis.

Step E8. Connect the four **Fan Assembly** power cables to their respective fan connectors on the **motherboard** as described in the **motherboard** installation guide.

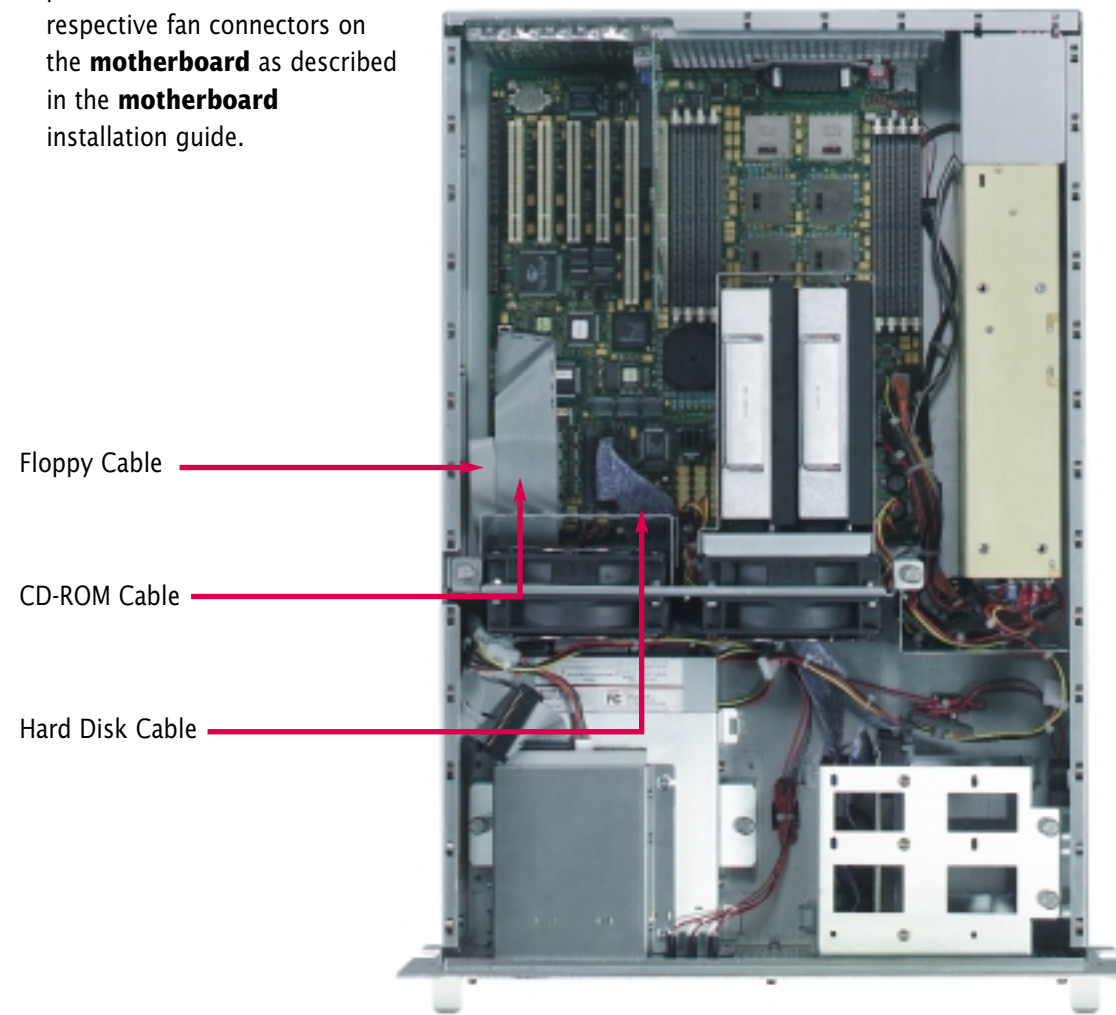

Note: When installing the various ribbon cables, ensure that the cables do not obstruct fan airflow.

F Install Modules & Cover

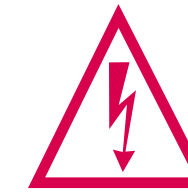

CAUTION: A grounding wrist strap must be worn and connected to the chassis prior to performing module installation.

Step F1. Install memory **DIMMs** into the **motherboard** per the motherboard installation guide.

Step F2. Install the **Goalpost Assembly** onto the **motherboard**.

- F2.1) Orient the assembly as indicated in the associated illustration.
- F2.2) Insert the four Phillips-head (M4x8mm) screws into the feet on the assembly. Tighten screws to 17 inch-pounds to secure the assembly to the chassis.

Step F3. Install **Alpha Slot B Modules** into the **motherboard** per the motherboard installation guide.

Step F4. Install **PCI Modules** into the **motherboard** per the manufacturer's instructions. Tighten hex-head screws on connector plate to 10 inch-pounds.

Step F5. Install the **Top Cover** and secure it to the chassis using the 3 rear-mounted Phillips-head screws. Tighten screws to 14 inch-pounds.

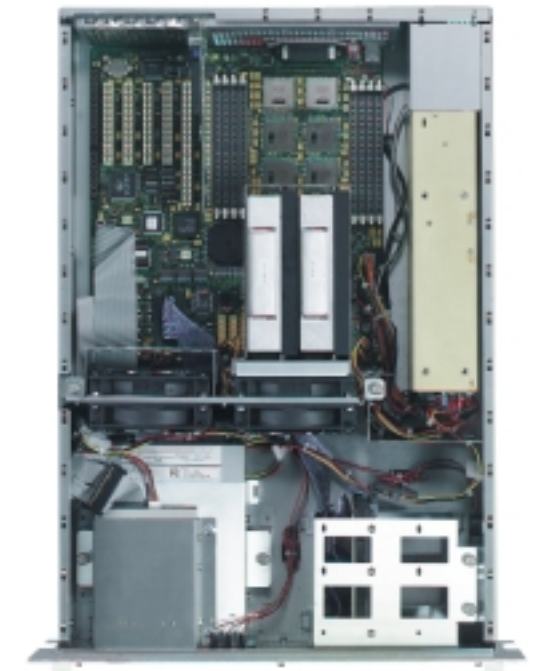

G Install Rack Mounting Hardware

Note: The rack mounting hardware consists of two slide assemblies and associated hardware, one assembly for each side of the chassis. **Tighten all screws and nuts in this procedure to 17 inch-pounds.**

Assemble Slide Kits (Steps G1-G6)

Step G1. Separate the **inner** and **outer rails** of one **slide assembly**.

- G1.1) Slide the **inner rail** toward the front of the assembly until it stops.
- G1.2) Depress the leaf-spring metal latch in center of horizontal surface on the **inner rail** and continue sliding the rail forward until it disengages from the **outer rails**.

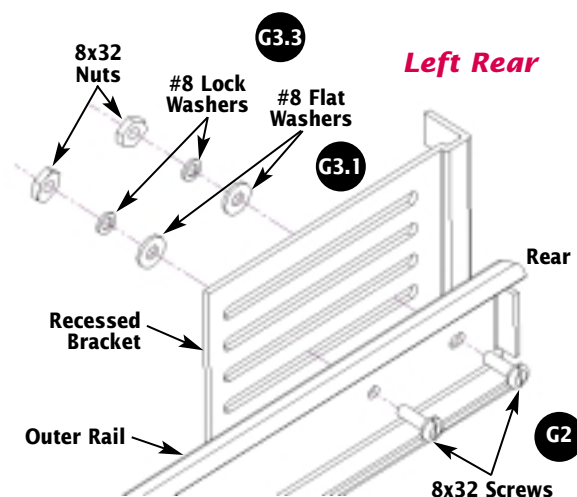

Step G2. At the rear of the **outer rails**, insert two 8x32 (0.5 in. long) slot-head screws through the bracket mounting holes.

Step G3. Install a **recessed bracket** on the **rear** of the **outer rail**.

- G3.1) Orient the bracket with the pillar mounting slots at the rear and the slot openings facing away from the rail, as shown.
- G3.2) Position the bracket on the back side of the rail so that the two screws on the rail extend through the second-from-the-bottom slot on the bracket.

- G3.3) Place one flat washer, one lock washer then one nut on each of the screws.
- G3.4) Using an 11/32-inch nut driver, tighten the two nuts sufficiently to hold the bracket flush against the rail, but loose enough to allow the bracket to slide on the rail.

Step G4. At the **front** of the **outer rail**, perform the following:

- G4.1) Slide the **ball retainer** forward to expose one of the two bracket mounting holes. Insert a 8x32 (0.5 in. long) slot-head screw through the hole.
- G4.2) Slide the **ball retainer** forward or rearward to expose the other bracket-mounting hole. Insert a 8x32 (0.5 in. long) slot-head screw through the hole.
- G4.3) Slide the **ball retainer** into a position that prevents the two slot-head screws from falling out of the **outer rail**.

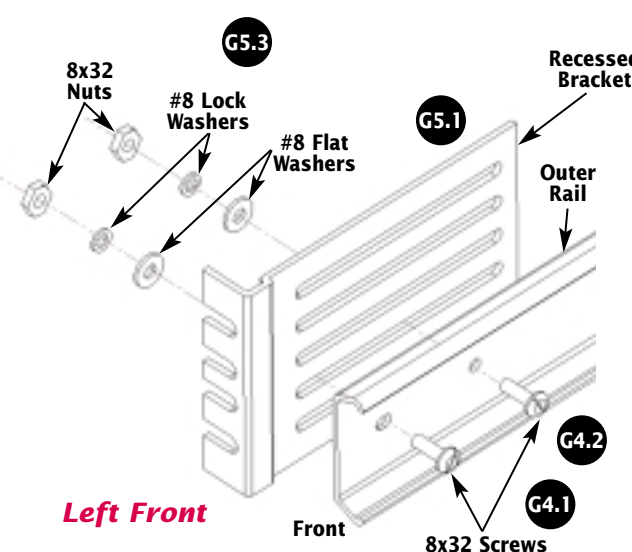

Step G5. Install a **recessed bracket** on the **front** of the outer rail.

- G5.1) Orient the bracket with the pillar mounting slots at the front and the slot openings facing away from the rail, as shown.
- G5.2) Position the bracket on the back side of the rail so that the two screws on the rail extend through the second-from-the-bottom slot on the bracket.
- G5.3) Place one flat washer, one lock washer then one nut on each of the screws.
- G5.4) Slide the bracket forward until the end of the rail is flush with the shoulder of the bracket.
- G5.5) Tighten the two nuts to securely hold the bracket in place on the rail.

Note: While performing the next step, move the ball retainer as needed to access each screw and prevent it from rotating.

Step G6. Repeat Steps G1 through G5 for the second **slide assembly**, attaching the components to form a mirror image of the previously installed slide assembly.

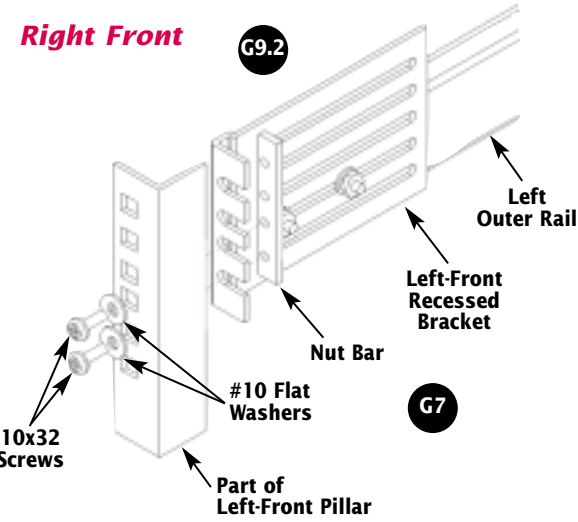

Install Slides into Rack (Steps G7-G10)

Step G7. At the **front** of the rack, install **nut bars** on the left and right front pillars using two 10x32 (0.5 in. long) Phillips-head screws and flat washers in the lowest two holes in each bar. Make sure **nut bars** are installed at the same height on left and right pillars.

Step G8. Repeat Step G7 at the **rear** of the rack, at same height as front pillars.

Step G9. Install the **left outer rail assembly** into the left side of the rack.

- G9.1) Insert the lowest two mounting slots on the **recessed bracket** at the rear of the **outer rail assembly** between the **nut bar** and the left rear pillar of the rack.

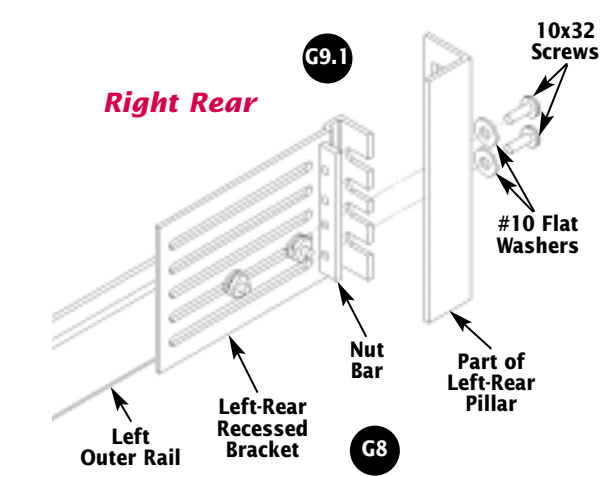

- G9.2) At the front of the **outer rail assembly**, pull the **recessed bracket** forward sufficiently to allow the two mounting slots on the bracket to slide between the **nut bar** and the left front pillar of the rack.
- G9.3) Tighten the two screws on the front and rear **nut bars** and screws on **outer rail recessed bracket** at rear.

Step G10. Repeat Step G9 for the **right outer rail assembly**. Make sure it is mounted in the rack as a mirror image of and at the same horizontal position as the **left outer rail assembly**. Leave outer rack mounting screws finger tight until chassis is installed. After the chassis is installed, tighten the screws completely.

Note: When tightening mounting screws, make sure inner faces of **recessed brackets** are flush with vertical edges of rack.

Step G10. Repeat Step G9 for the **right outer rail assembly**. Make sure it is mounted in the rack as a mirror image of and at the same horizontal position as the **left outer rail assembly**. Leave outer rack mounting screws finger tight until chassis is installed. After the chassis is installed, tighten the screws completely.

Install Chassis into Rack (Steps G11-G17)

Step G11. Install the **right inner rail** on the chassis.

- G11.1) Place the flat side of the **right inner rail** against the chassis and align the screw holes on the rail with the threaded holes in the chassis.
- G11.2) Attach the rail to the chassis using four M4x0.7 (8 mm long) slot-head screws then tighten screws to secure the rail.

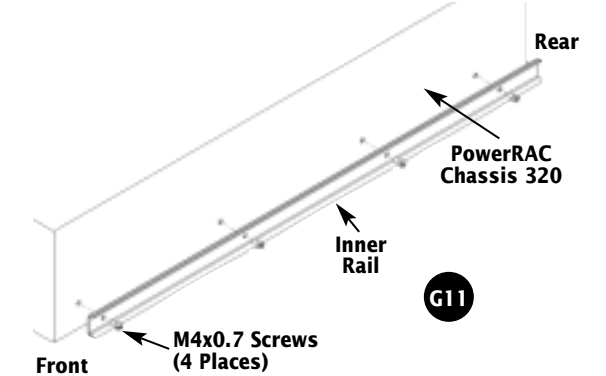

Step G12. Repeat Step G11 for the **left inner rail**. Make sure it is mounted as a mirror image of the **right inner rail**.

Step G13. Lift the PowerRAC Chassis 320 and move it into position in front of the rack into which it will be installed.

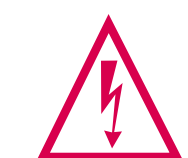

CAUTION: A fully loaded PowerRAC Chassis 320 weighs more than 50 pounds. Two people are required to perform steps G14 through G17.

Step G14. Orient the chassis so that the rears of the inner rails are aligned with the fronts of the **outer rail assemblies** on the rack.

Step G15. Being careful to keep the chassis horizontal, simultaneously insert both **inner rails** into the **outer rail assemblies**. Slowly push the chassis into the rack until it stops.

Step G16. Simultaneously depress the **latches** on both **inner rails** then slowly slide the chassis the rest of the way into the rack.

Step G17. At the **front** of the chassis, insert two 10x32 (0.5 in. long) Phillips-head screws with flat washer installed through the front panel and into the left and right **nut bars**. Tighten the screws to secure the chassis in the rack.

