



StorageWorks Secure Path

White Paper: A No Single Point of Failure Solution for Windows NT

Table of Contents

A No Single Point of Failure Solutions for Windows NT	2
Secure Path Technology	3
Implementation	3
Installation and Configuration	4
Present and Future	4
Ordering Information	5

A No Single Point of Failure Solution for Windows NT

StorageWorks Secure Path is a high availability software product providing continuous data access for RAID Array 7000/Enterprise Storage Array 10000 storage subsystems configured on Windows NT™ 4.0 Intel™ or Alpha™ platforms. Redundant hardware, advanced RAID technology and automated failover capability are used to enhance fault tolerance and availability. Secure Path effectively eliminates controllers, disk drives, interconnect hardware and host bus adapters as single points of failure in the storage subsystem.

Secure Path v1.0 allows a dual-controller StorageWorks™ RA7000/ESA10000 to be cabled on two independent SCSI busses, using two separate host bus adapters in a single server configuration.

Secure Path monitors each path and automatically re-routes I/O to the functioning, alternate path should an adapter, cable, or controller failure occur. Failure detection is reliable and designed to prevent false or unnecessary failovers. Failovers are transparent and non-disruptive to applications.

The Secure Path management utility provides continuous monitoring capability and identifies failed paths and failed-over storage units. To facilitate static load balancing, drives can be moved between paths using simple “drag-and-drop” operations.

Through use of dual RAID controllers, configured in an active/active multibus mode of operation, Secure Path can also exploit the potential for improved data throughput and bandwidth performance.

Secure Path Technology

Key to Secure Path's functionality is the capability of dual RA7000/ESA10000 controllers to operate in an active/active implementation referred to as dual-redundant multibus mode. Multibus mode allows each controller to be configured on its own bus and to process I/O independently under normal operation. Available storage units are "preferred" to one or the other of the two controllers by setting a PREFERRED_PATH unit attribute. This attribute determines which controller path is used for access at system boot time. During runtime, units may be moved between paths at anytime through use of the management utility.

Controllers in a dual-redundant multibus configuration monitor each other and automatically and transparently failover storage units from the failed member of a controller pair. The Secure Path software detects the failure of I/O operations to complete on a failed controller's path and automatically re-routes all traffic to the path of the surviving controller. Controller and path failover is completed seamlessly, without process disruption or data loss.

Following a warm-swap of a failed controller, adapter or cable component, storage units can be failed-back to their original path using the Secure Path management utility.

To protect against drive failure in a Secure Path environment, storage units can be configured using RAID levels 0+1, 1, 3/5, or 5. Secure Path will support either FAT or NTFS file system formats.

Implementation

Secure Path's primary failover capability is implemented in a Windows NT filter driver called RaiDisk. RaiDisk provides support for the RA7000/ESA10000 multibus mode of operation and provides all functions required to monitor I/O and detect path failures. RaiDisk also filters the alternate path view to a storage unit so that application level programs and utilities, such as Explorer and Disk Administrator, report a logically consistent view of the underlying storage environment. RaiDisk uses custom event log entries to facilitate problem diagnosis and repair. Performance testing with Secure Path installed demonstrates that there is less than a 0.5% performance reduction attributable to the RaiDisk driver.

Secure Path also incorporates the custom Windows NT class driver, HszDisk, developed for use with RA7000/ESA10000 and other StorageWorks RAID Array controllers. This class driver provides unique error handling features and performance enhancements not available in the native Windows NT disk class driver.

Multi-path management is implemented using Secure Path Manager (SPM). SPM is a graphical user interface (GUI)-based application that continuously monitors the multi-path storage environment and automatically updates the displayed configuration information. SPM indicates which path is currently servicing each configured storage unit. Online, offline, and pending state information for available storage units and paths is depicted using color codes. The capability to swap storage units between paths is also provided through simple "drag-and-drop" operations.

Installation and Configuration

A version 1.0 Secure Path configuration is comprised of a server, two host bus adapters, a RA7000/ESA10000 subsystem, two sets of UltraSCSI cables, and two terminators. A Secure Path single server configuration is shown in Figure 1.

All Secure Path software components are installed on either Intel or Alpha based platforms using the same InstallShield-based setup utility. The setup procedure requires that a standard single path configuration be established, with all storage units defined, prior to installation of the Secure Path software. The Secure Path software is then installed on the single path configuration before re-configuration of the storage controllers for multibus mode and installation of hardware for the redundant path. This software-first/hardware-second procedure allows the operating system to properly configure the multi-path environment when rebooted.

For previously installed subsystems, no modifications are required to existing storage units or data volumes.

Figure 1
Secure Path v1.0 Single Server Configuration

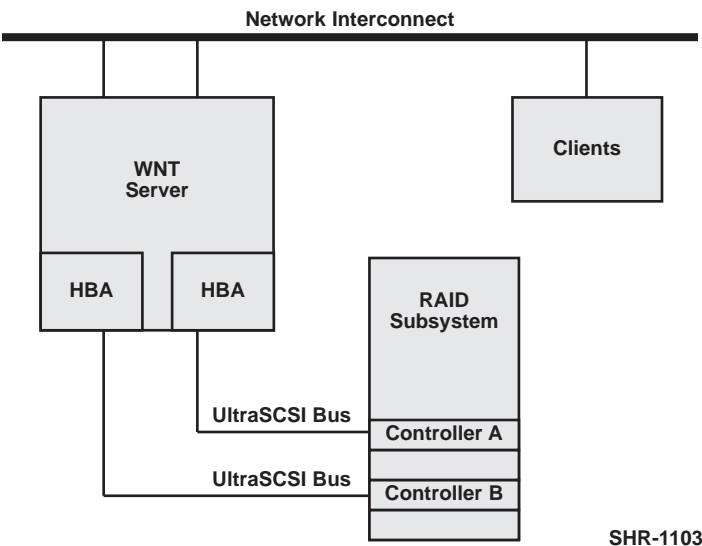

Present and Future

In its first product release, StorageWorks Secure Path offers significantly reduced down-time and enhanced data availability through the elimination of single points of failure in UltraSCSI single host server environments.

In Secure Path version 2.0, StorageWorks will introduce support for Windows NT clusters, Fibre Channel, and auto-failback capability. A No Single Point Of Failure (NSPOF) Solution using Windows NT clusters and Secure Path for v2.0 is shown in Figure 2.

Auto-failback will monitor a failed path and automatically return failed-over storage units to their original path once it has been restored. Anti-thrash filters are implemented to prevent ping-pong effects resulting from marginal or intermittent conditions. The user will be able to select the auto or manual failback policy through use of the management utility.

The integration of Secure Path, Windows NT clustering, and StorageWorks RAID Array Fibre technologies will provide the maximum levels of fault-tolerance, data availability, and performance required for mission-critical environments.

Figure 2
No Single Point of Failure (NSPOF) Solution Using Windows NT Clusters and StorageWorks Secure Path for Windows NT V2.0

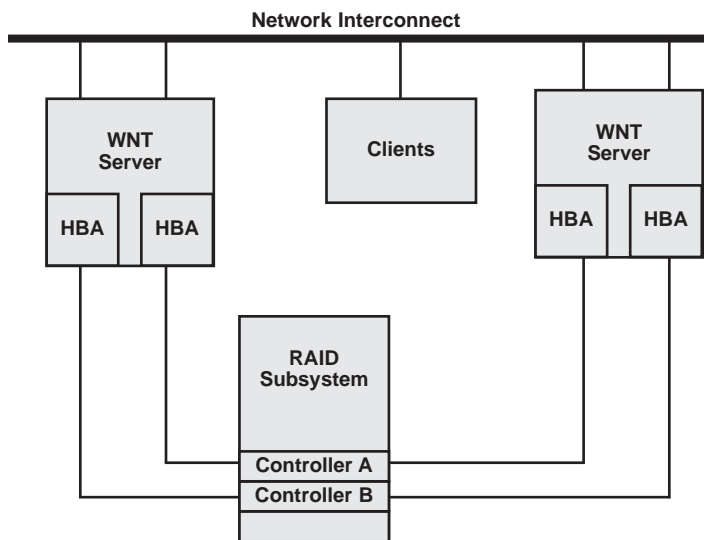

Ordering Information

Part Number	Product Name	Supports
QB-669AA-SA	Secure Path for Windows NT V1.0 (available now)	SCSI - RA7000/ESA10000 Single Host
—	Secure Path for Windows NT V2.0 (available Q4 1998) Single Host & Windows NT Clusters	SCSI - RA7000/ESA10000 Fibre - RA8000/ESA12000



NOTICE

The information in this publication is subject to change without notice.

COMPAQ COMPUTER CORPORATION SHALL NOT BE LIABLE FOR TECHNICAL OR EDITORIAL ERRORS OR OMISSIONS CONTAINED HEREIN, NOR FOR INCIDENTAL OR CONSEQUENTIAL DAMAGES RESULTING FROM THE FURNISHING, PERFORMANCE, OR USE OF THIS MATERIAL.

This publication does not constitute an endorsement of the product of products that were tested. The configuration or configurations tested or described may or may not be the only available solution. This test is not a determination of product quality or correctness, nor does it ensure compliance with any federal, state or local requirements.

Compaq does not warrant products other than its own strictly as stated in Compaq product warranties.

Compaq believes the information in this publication is accurate as of its publication date; such information is subject to change without notice. Compaq is not responsible for any inadvertent errors.

Compaq conducts its business in a manner that conserves the environment and protects the safety and health of its employees, customers, and the community.

Compaq is a registered trademark of Compaq Computer Corporation. Alpha and StorageWorks are trademarks of Compaq Computer Corporation.

Intel is a trademark of Intel Corporation. Windows NT is a trademark of Microsoft Corporation.